

1 Trail Rookie WRC
Reitertreffen Weiz-Preding 2021

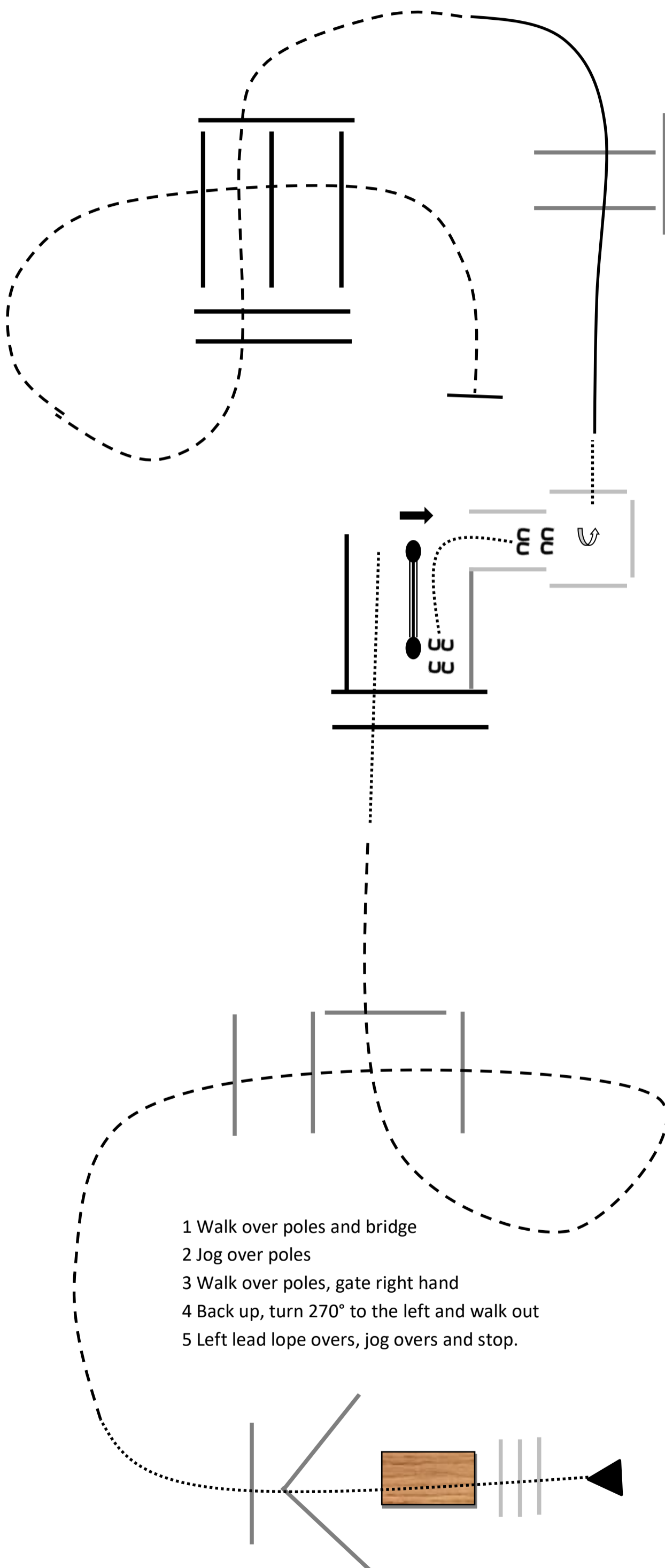

2 Youth Trail LZF
 Reitertreffen Weiz-Predding 2021

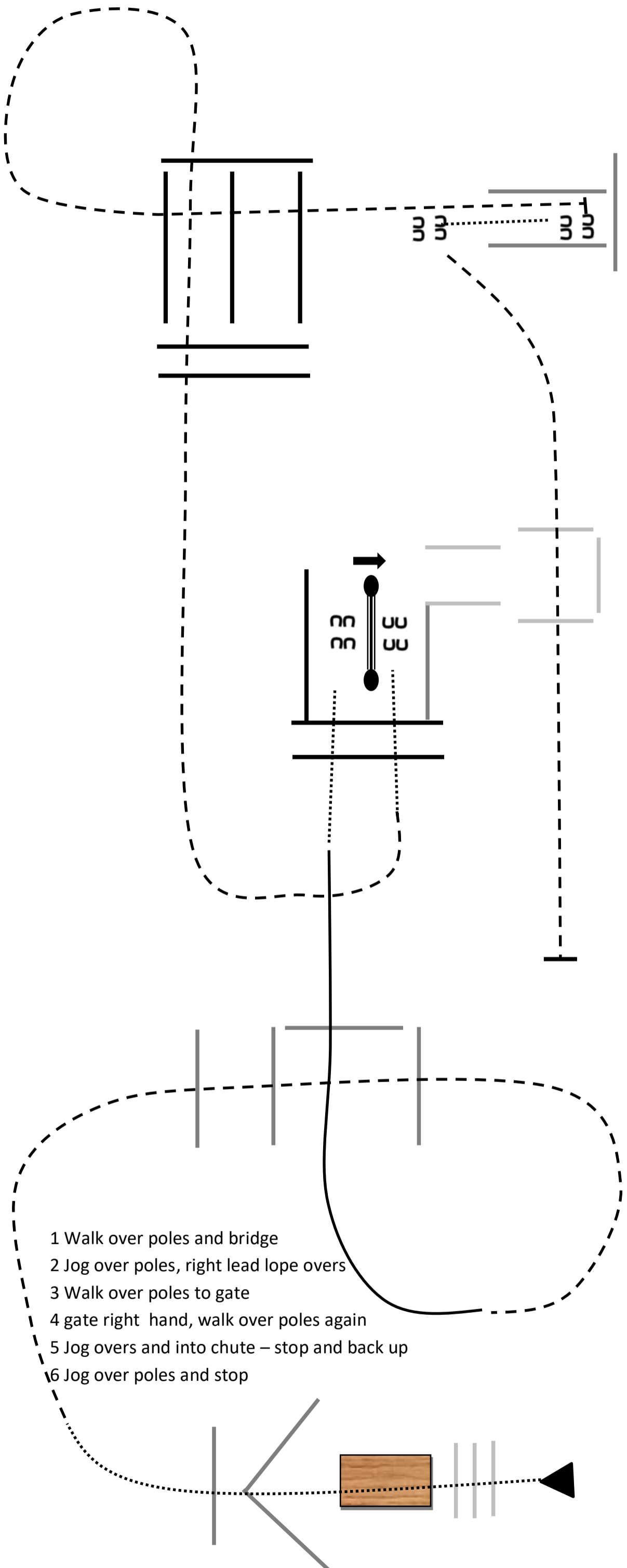

3 Horsemanship Rookie WRC Reitertreffen Weiz-Preding 2021

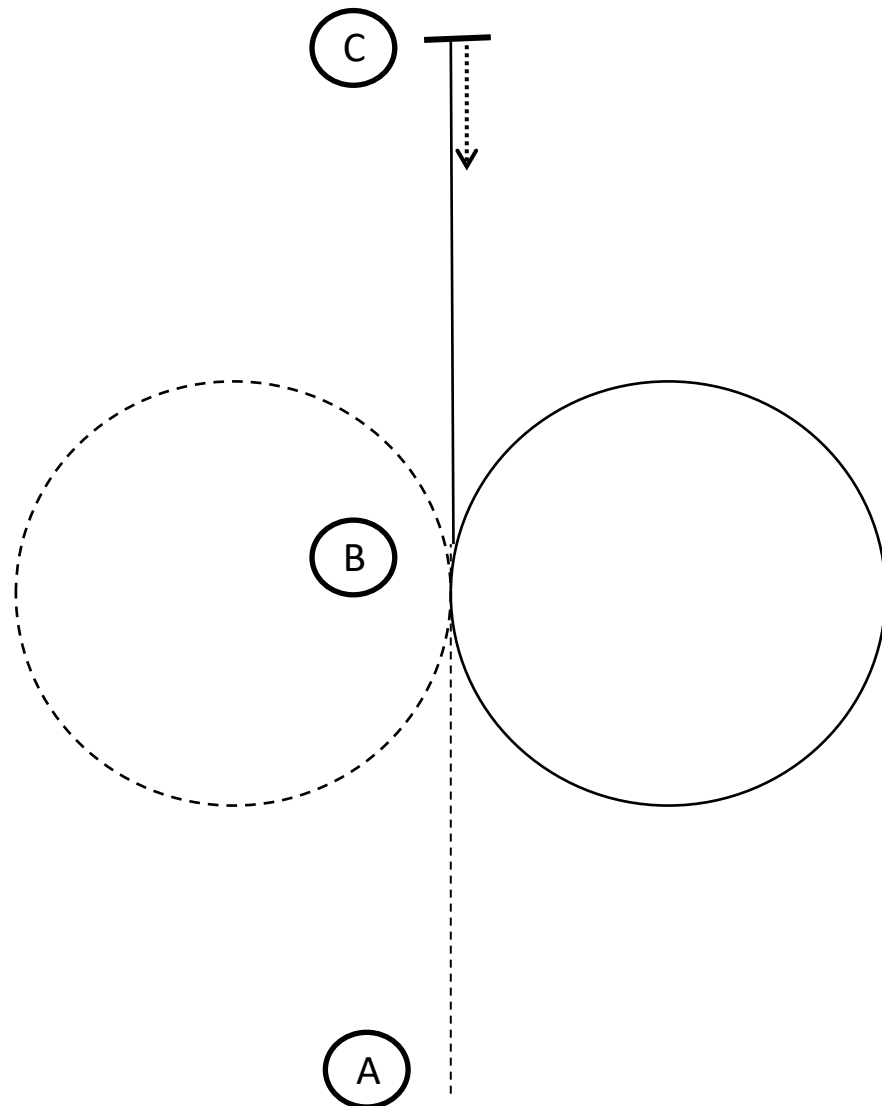

- | | | | |
|---|---|---|--------------------------------|
| 1 | Jog A to B | 4 | Continue the lope from B to C |
| 2 | At B jog a circle to the left | 5 | Stop at C and back four steps. |
| 3 | At B lope a circle to the right on the right lead | | |

4 Horsemanship Youth LZF Reitertreffen Weiz-Preding 2021

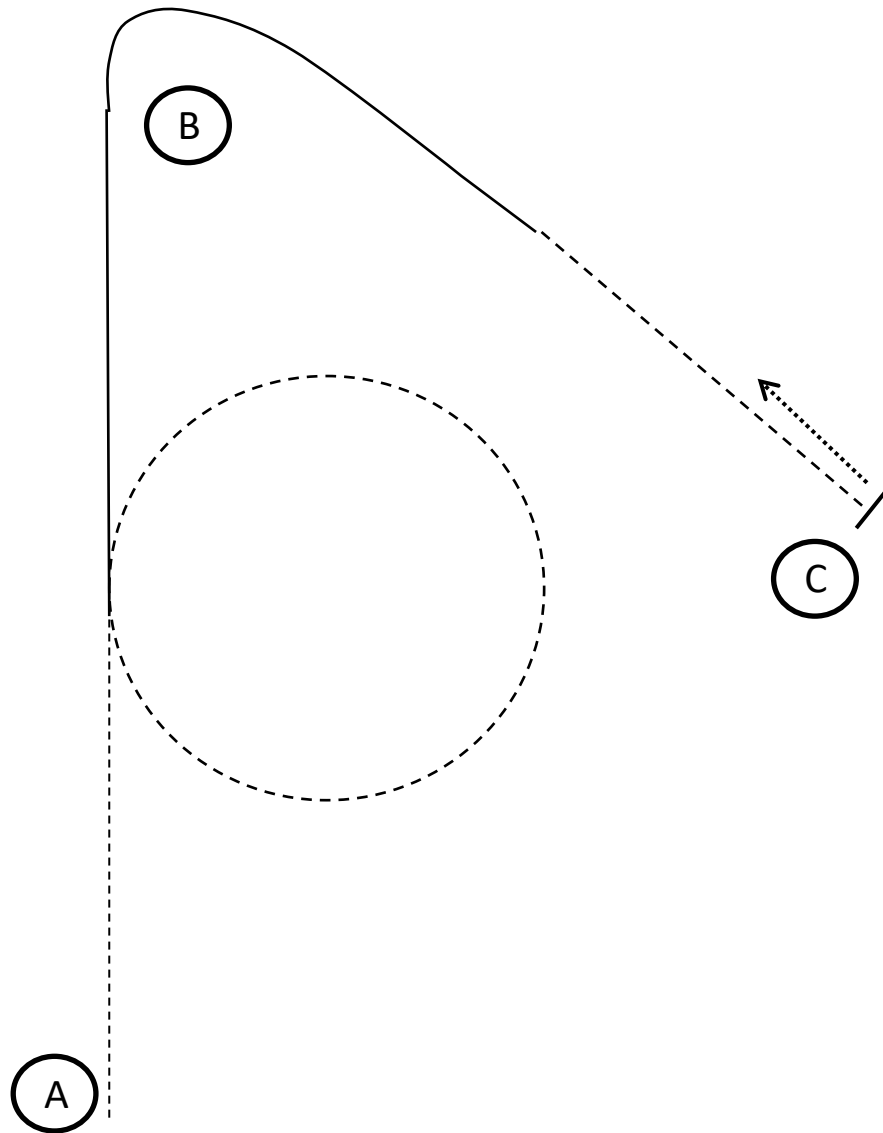

- | | | | |
|---|---|---|------------------------------|
| 1 | Be ready at A | 4 | Break into jog to C |
| 2 | Jog from A halfway to B and perform a circle to the right | 5 | Stop at C and back six steps |
| 3 | Lope to and around B and halfway to C | | |

5 Horsemanship Rookie Walk-trot WRC Reitertreffen Weiz-Preiding 2021

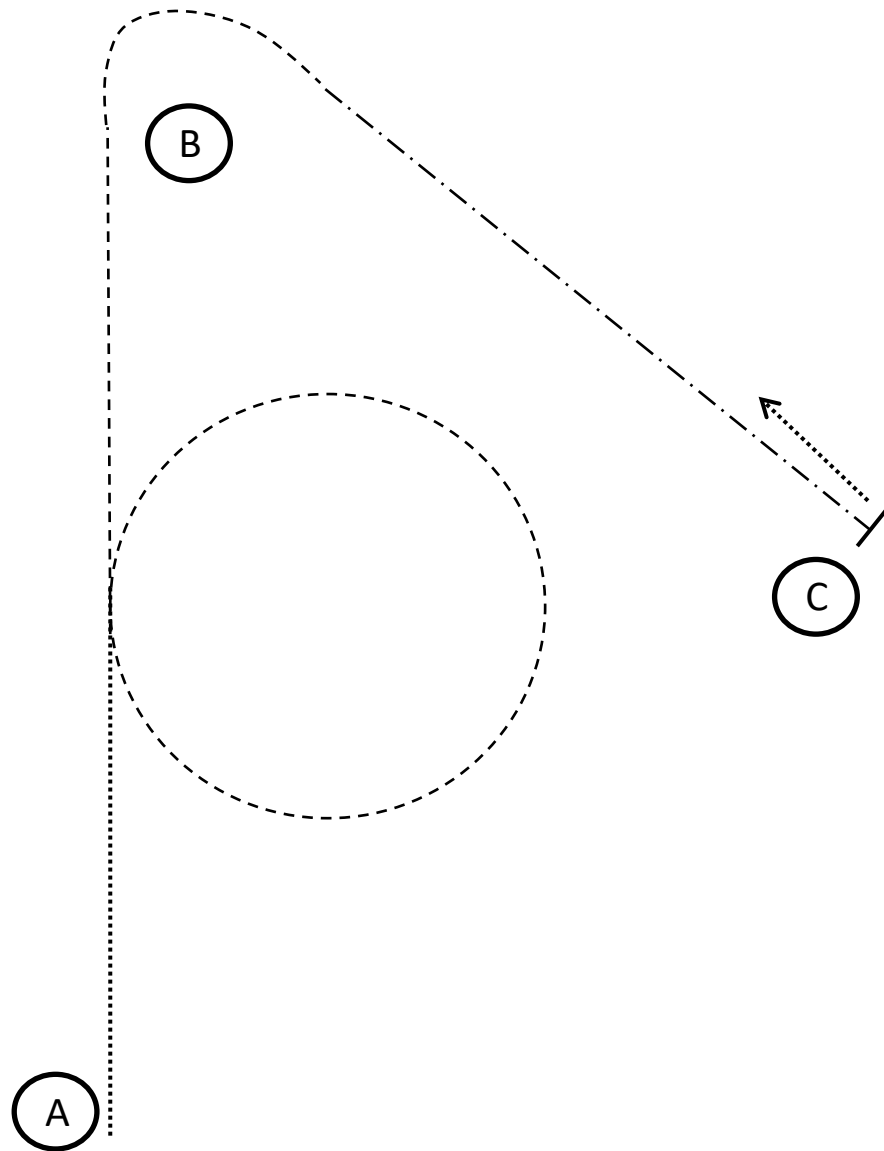

- | | | | |
|---|------------------------------|---|-------------------------------|
| 1 | Be ready at A | 4 | Jog to and around B and then |
| 2 | Walk from A halfway to B. | | perform an extended trot to C |
| 3 | At B perform a circle to the | 5 | Stop at C and back six steps |
| | right at the jog | | |

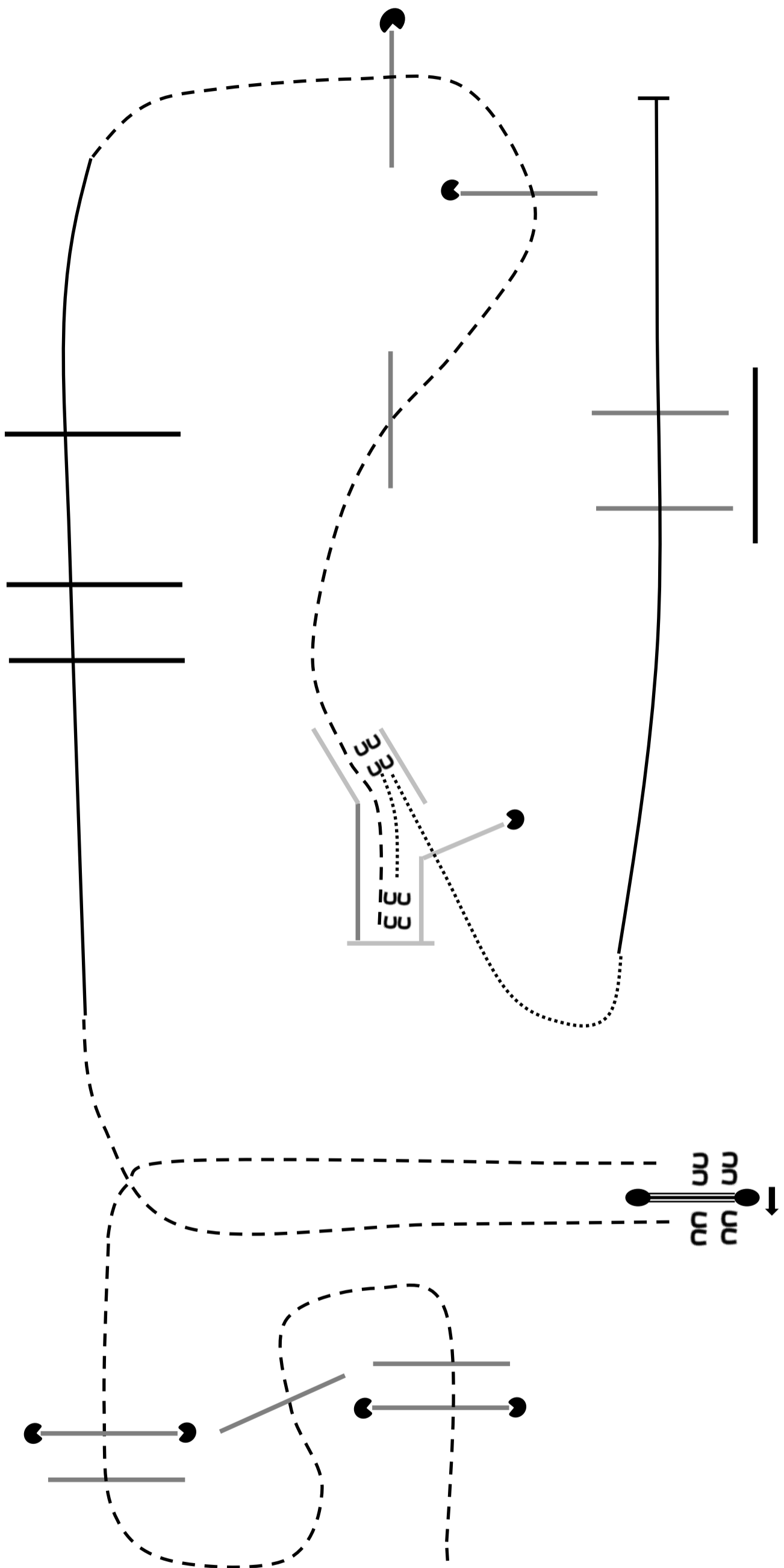

1. Walk over bridge, turn 450° right and walk out and over poles
2. Jog overs to gate, gate right hand
3. Jog and continue with right lead lope overs
4. Jog overs and into chute, back up
5. Walk over pole, turn around and lope over poles left lead.

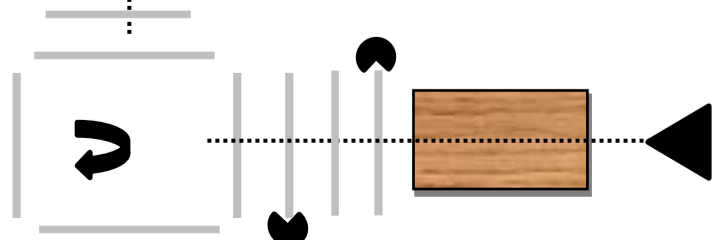

15 Trail Open WRC
Reitertreffen Weiz-Preding 2021

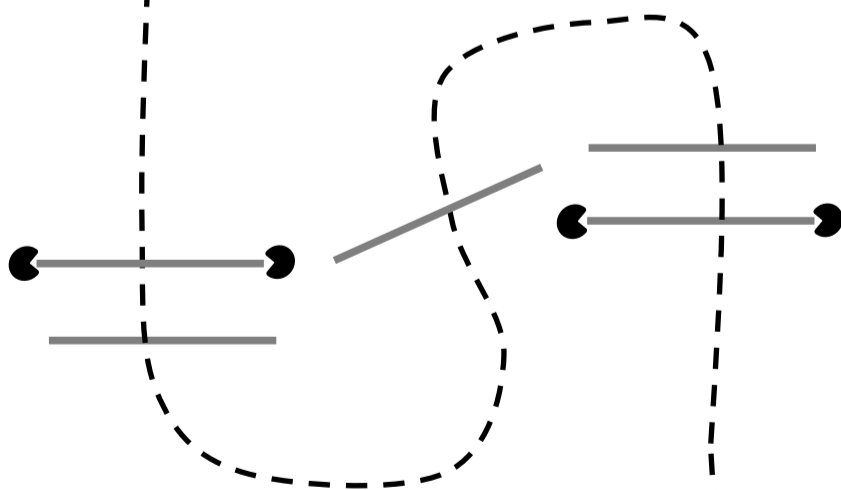
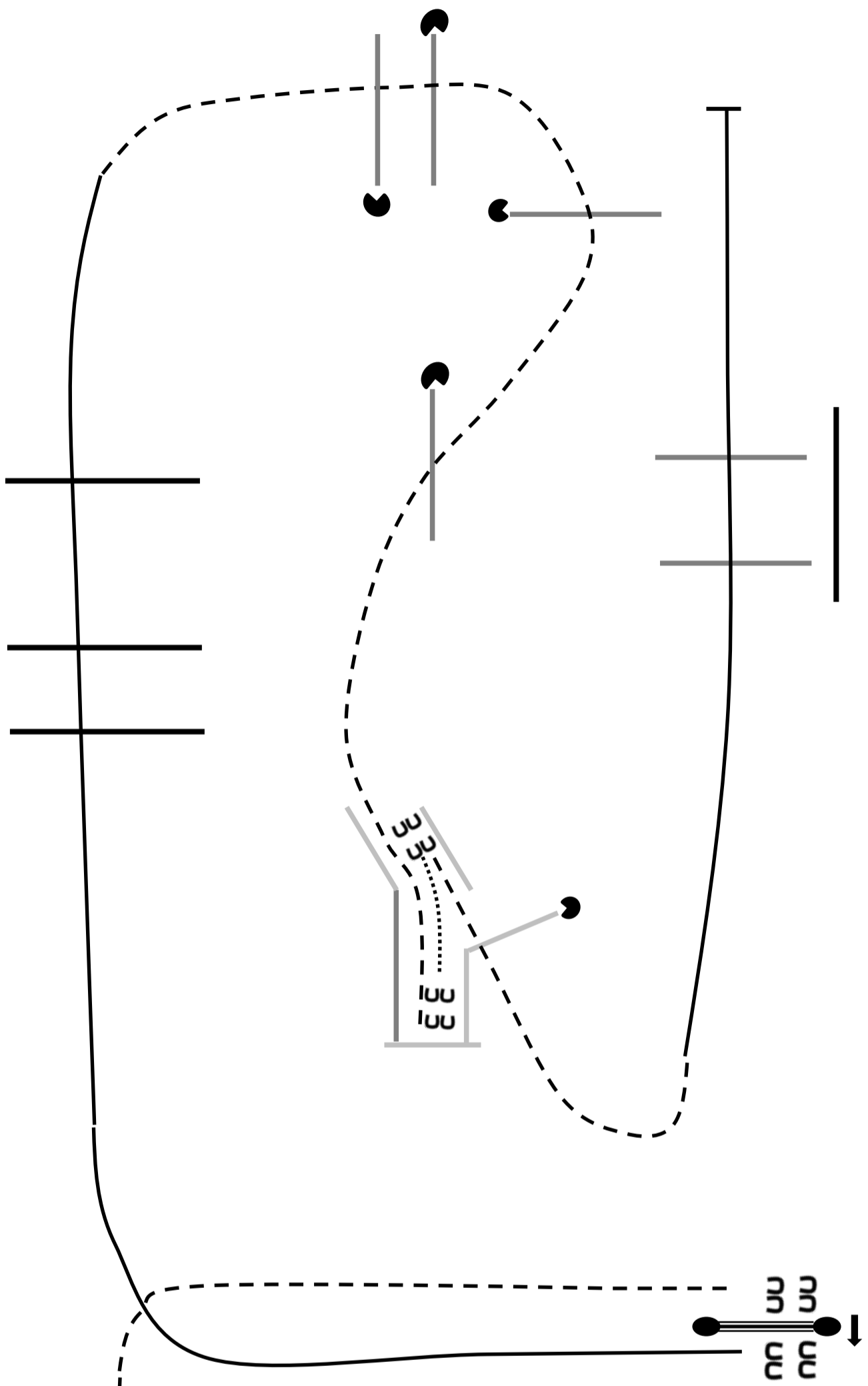

1. Walk over bridge, turn 450° right and walk out and over poles
2. Jog overs to gate, gate right hand
3. Right lead lope overs, break to jog
4. Jog overs and into chute, back up
5. Jog over pole, turn around and lope over poles left lead.

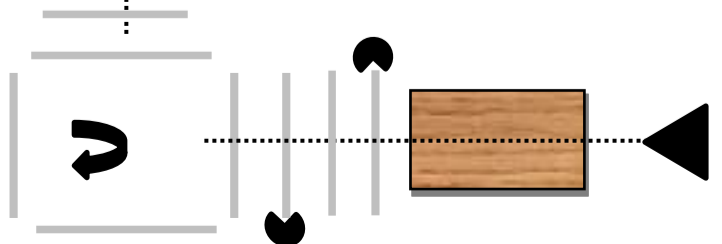

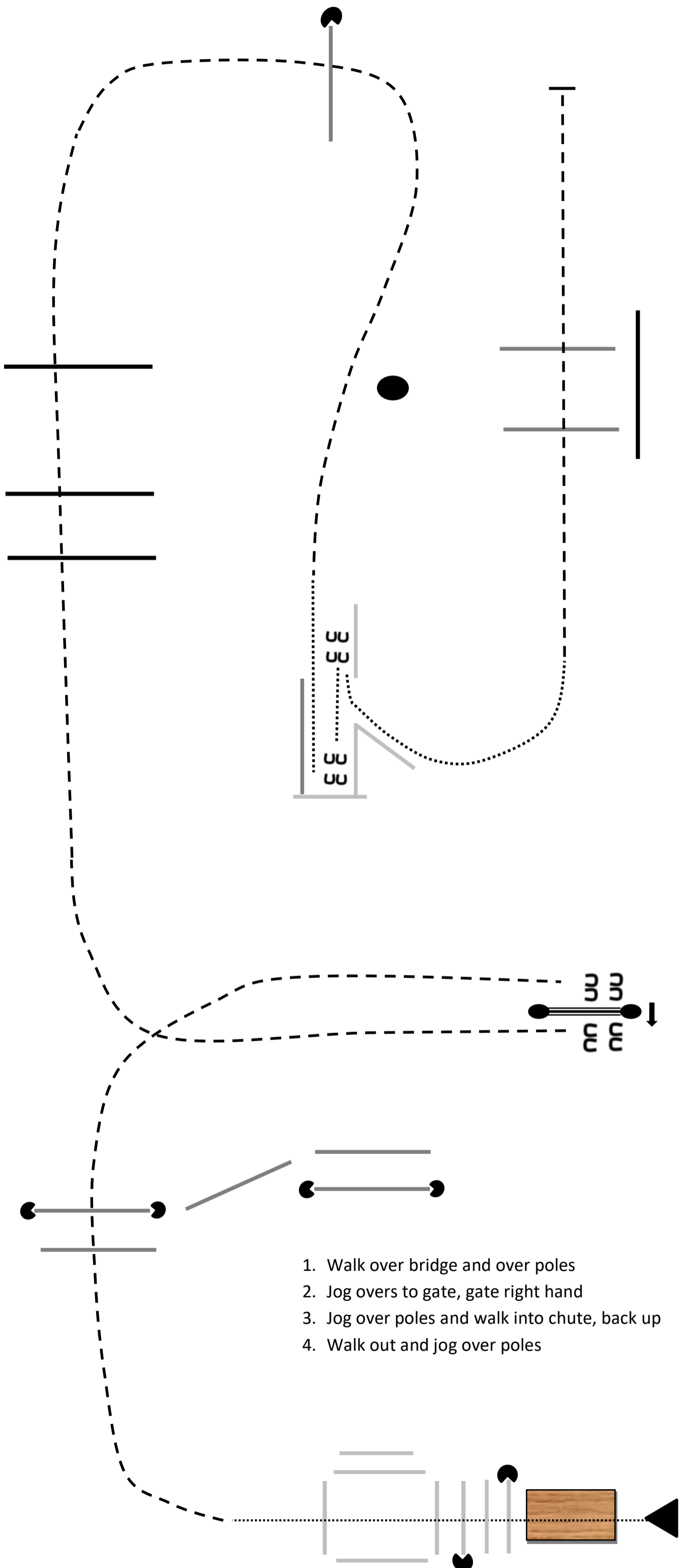

17 Horsemanship Amateur WRC
Reitertreffen Weiz-Preding 2021

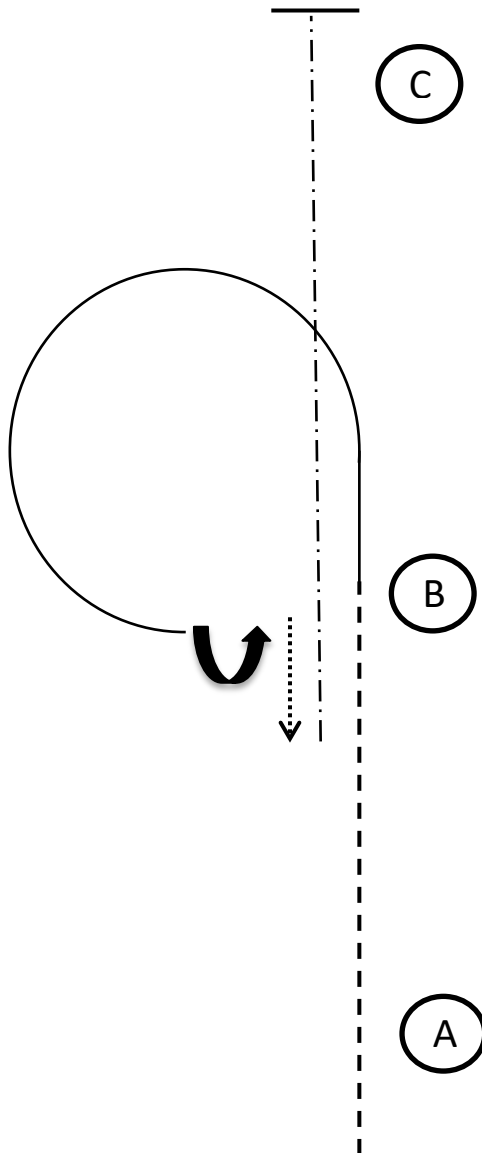

- | | | | |
|---|---|---|------------------------------|
| 1 | Jog one horse length before A and continue jogging to B | 4 | Turn 450° to the left. |
| 2 | At B lope a circle left lead to B | 5 | Back one horse length |
| 3 | Stop facing B | 6 | Extended trot to C and stop. |