

CWN-C ZNS/ARHA WTC Wr. Neustadt/NÖ - 30.4 - 02.5.2021  
 Bewerb 01 7380 R Trail Cup/AA

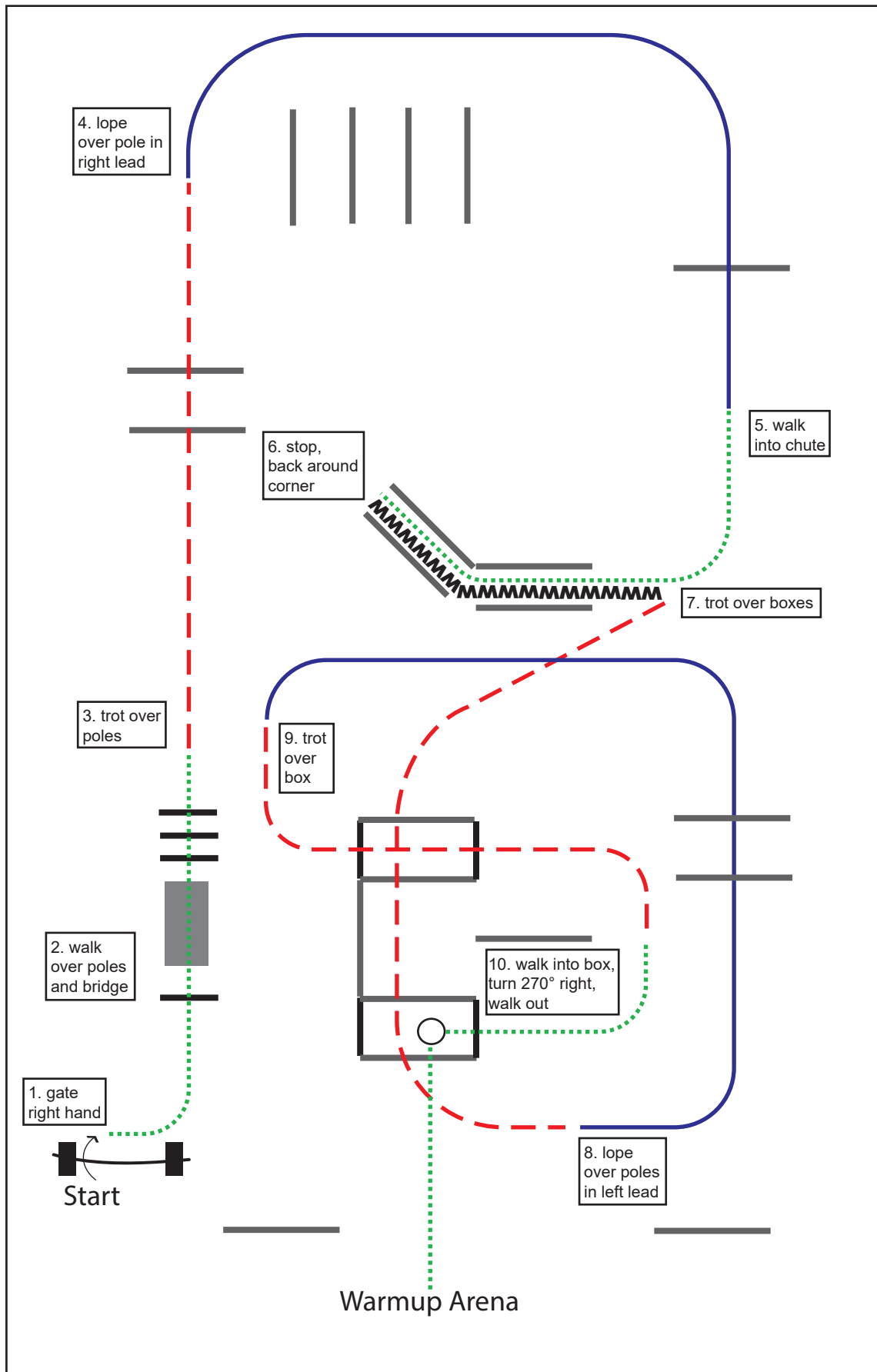

- ..... Schrittl
- - - - Trab
- Galopp
- MMM** Rückwärts
- $\overline{nn}$  → Seitwärts
- Pylonen
- X Erhöhungen
- ⊢ Tor



designed by Nina Zwölfer

CWN-C ZNS/ARHA WTC Wr. Neustadt/NÖ - 30.4 - 02.5.2021  
 Bewerb 02 2380 A Trail Cup

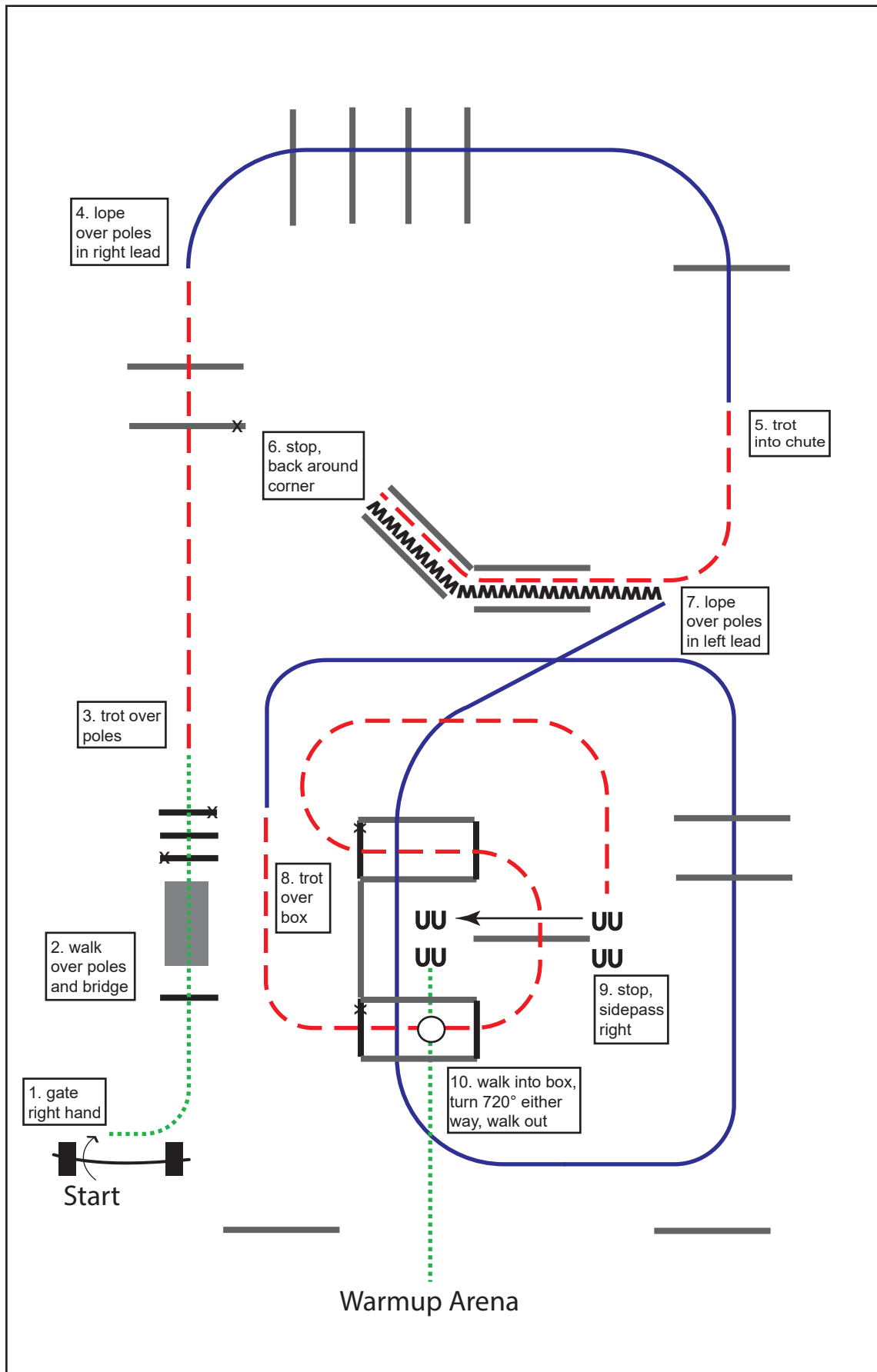

- ..... Schritt
- - - - - Trab
- Galopp
- MMM** Rückwärts
- $\overline{nn}$  → Seitwärts
- Pylonen
- X Erhöhungen
- ⌋ Tor



designed by Nina Zwölfer

CWN-C ZNS/ARHA WTC Wr. Neustadt/NÖ - 30.4 - 02.5.2021  
 Bewerb 03 1380 O Trail

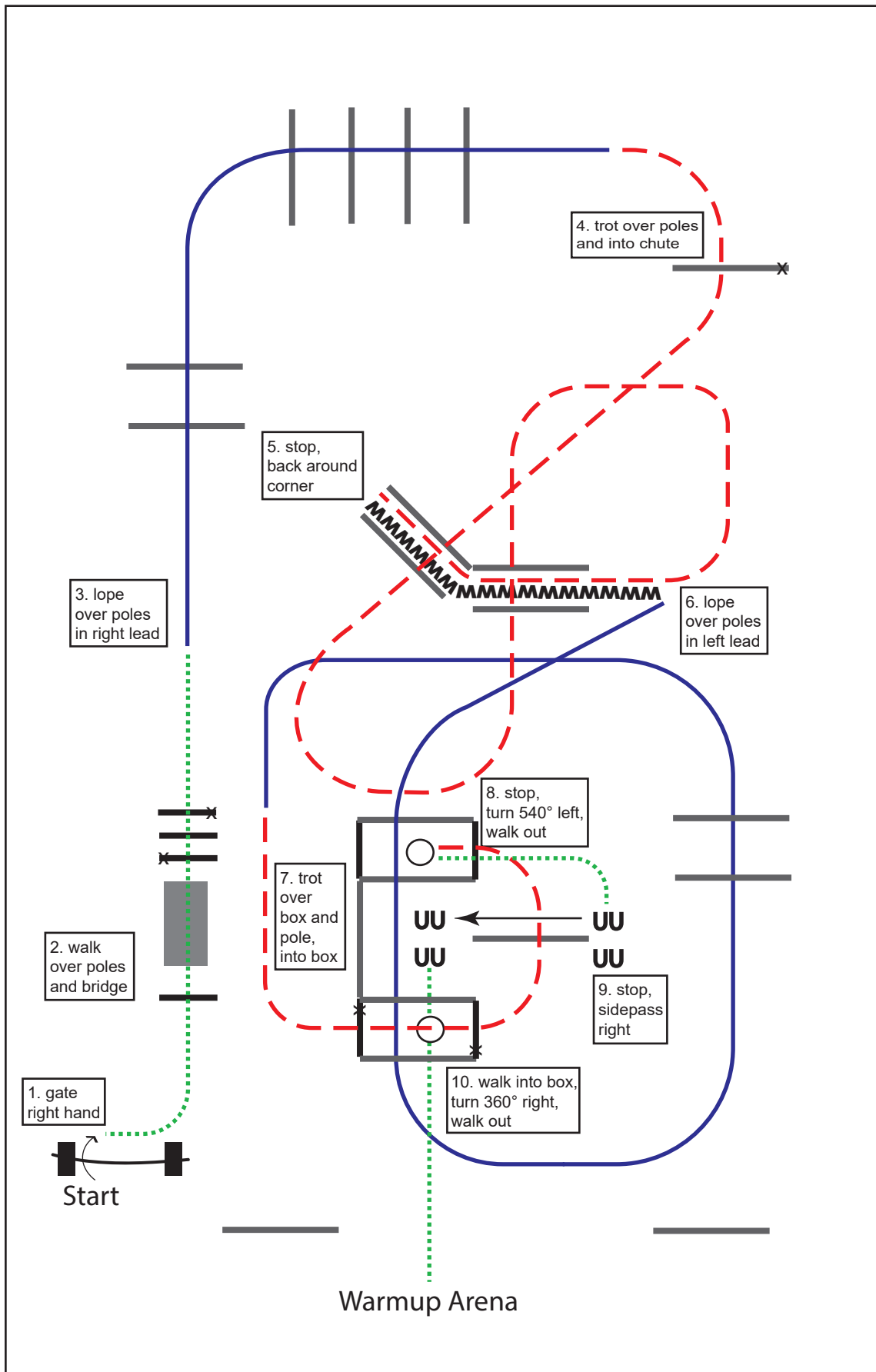

..... Schrittl

- - - - Trab

———— Galopp

MMMM Rückwärts

nn → Seitwärts

○ Pylonen

X Erhöhungen

H Tor



designed by Nina Zwölfer

CWN-C ZNS/ARHA WTC Wr. Neustadt/NÖ - 30.4 - 02.5.2021  
 Bewerb 04 1380 O Trail Prime Time

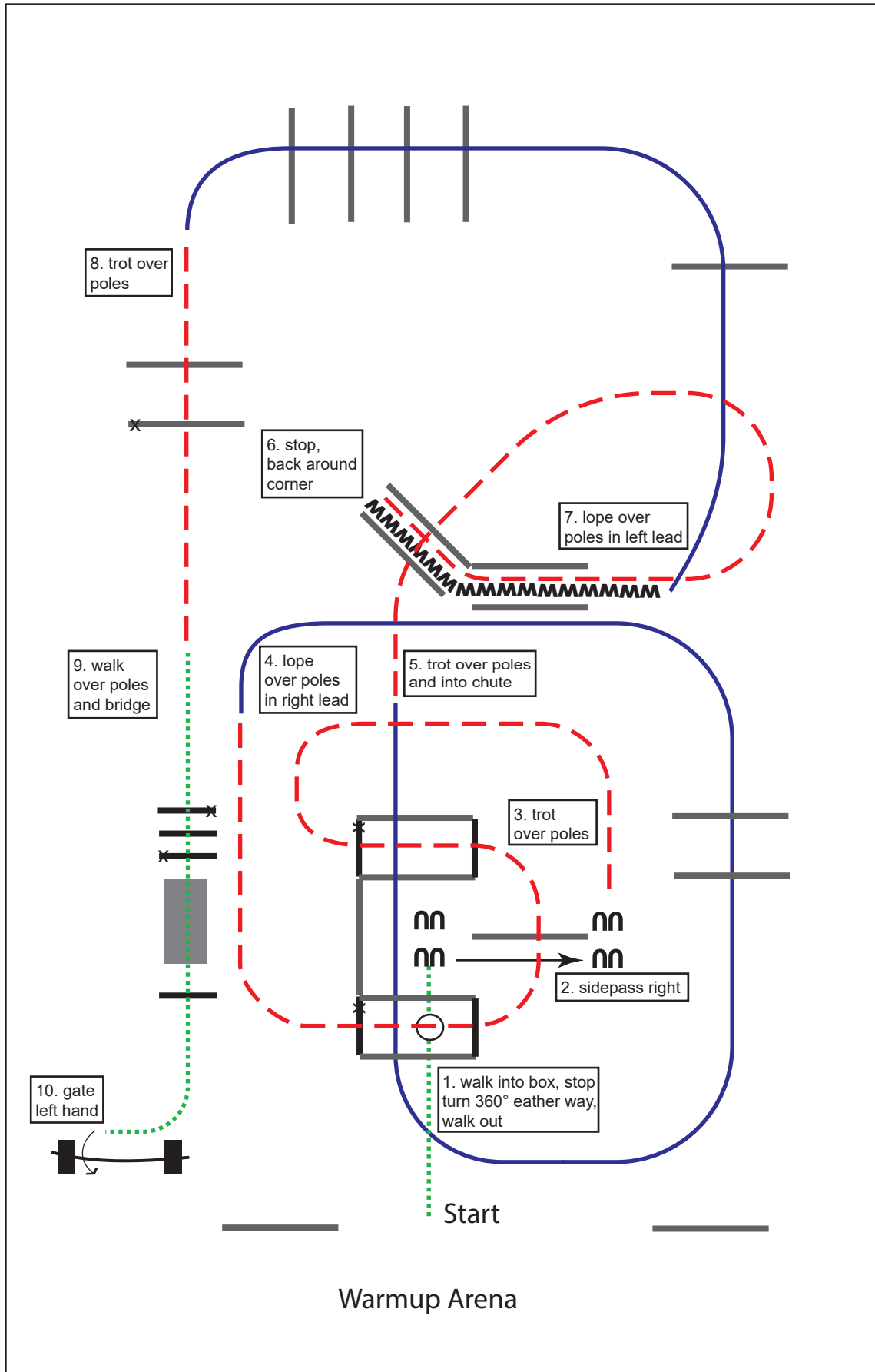

Warmup Arena

- |                |              |
|----------------|--------------|
| ..... Schritt  | ↔ Seitwärts  |
| - - - - - Trab | ○ Pylonen    |
| ———— Galopp    | X Erhöhungen |
| MMM Rückwärts  | ⊢ Tor        |



designed by Nina Zwölfer

CWN-C ZNS/ARHA WTC Wr. Neustadt/NÖ - 30.4 - 02.5.2021  
 Bewerb 05 3380 NA Trail Cup/AA

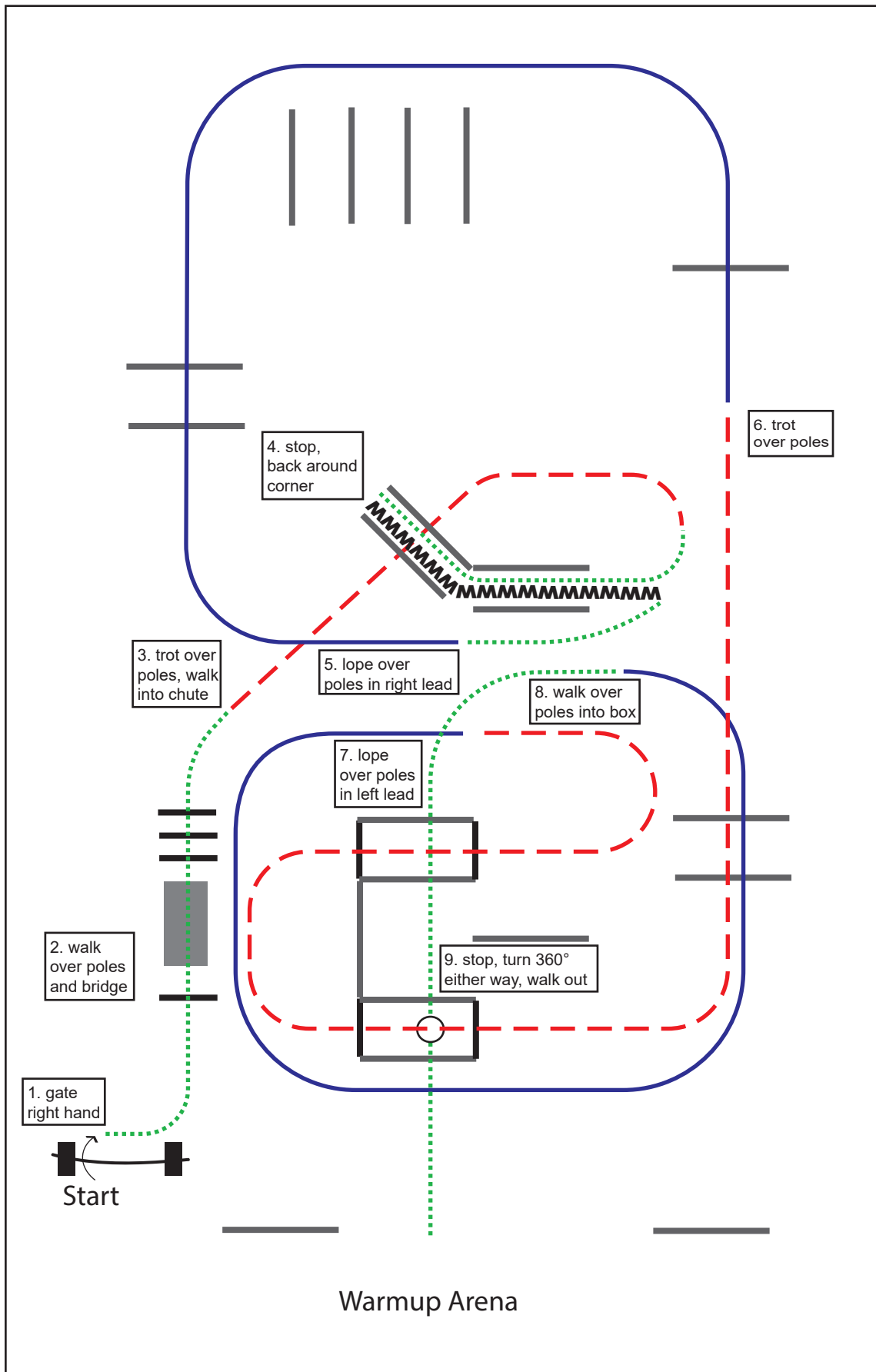

- |               |              |
|---------------|--------------|
| ..... Schritt | ↔ Seitwärts  |
| - - - - Trab  | ○ Pylonen    |
| — Galopp      | X Erhöhungen |
| MMM Rückwärts | ⊥ Tor        |



designed by Nina Zwölfer

CWN-C ZNS/ARHA WTC Wr. Neustadt/NÖ - 30.4 - 02.5.2021  
 Bewerb 26 7380 R Trail Cup

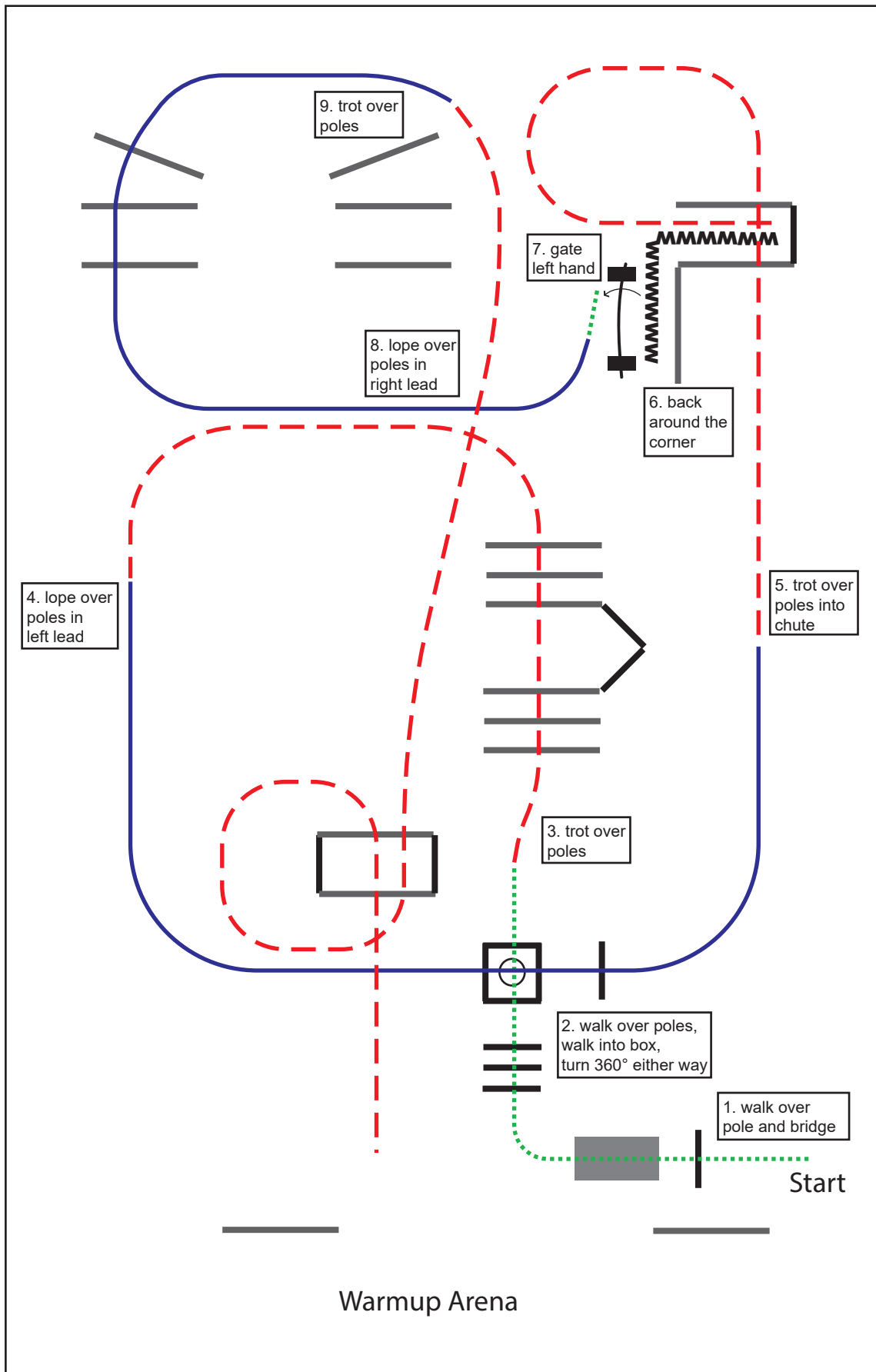

..... Schritt

- - - - - Trab

———— Galopp

MMM Rückwärts

↗ Seitwärts

○ Pylonen

X Erhöhungen

⊥ Tor



designed by Nina Zwölfer

CWN-C ZNS/ARHA WTC Wr. Neustadt/NÖ - 30.4 - 02.5.2021  
 Bewerb 27 8380 Y Trail Cup

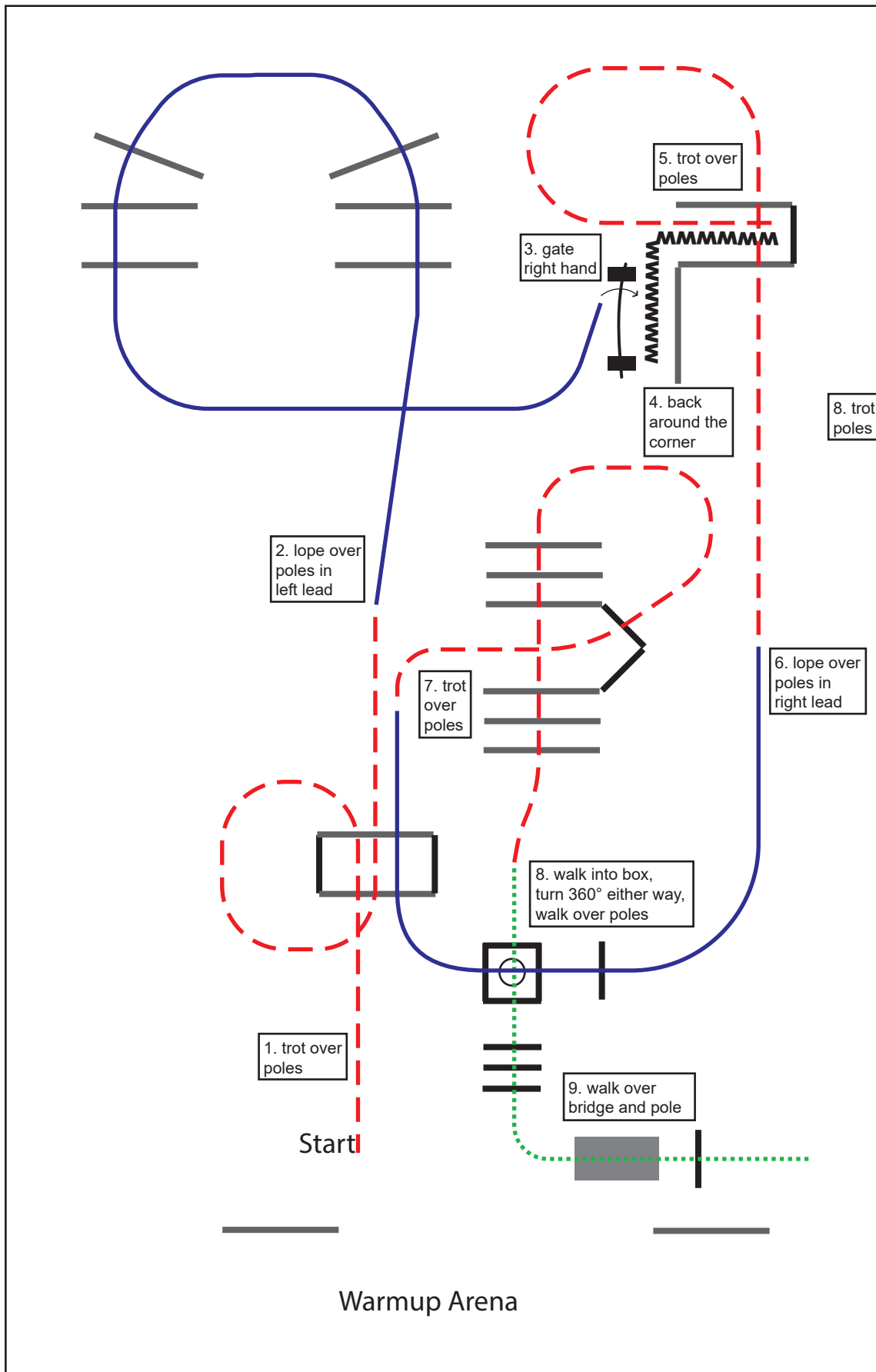

- ..... Schritt
- - - - - Trab
- Galopp
- MMM Rückwärts
- ↔ Seitwärts
- Pylonen
- X Erhöhungen
- ⊥ Tor



designed by Nina Zwölfer

CWN-C ZNS/ARHA WTC Wr. Neustadt/NÖ - 30.4 - 02.5.2021  
 Bewerb 28 8454 NY Trail

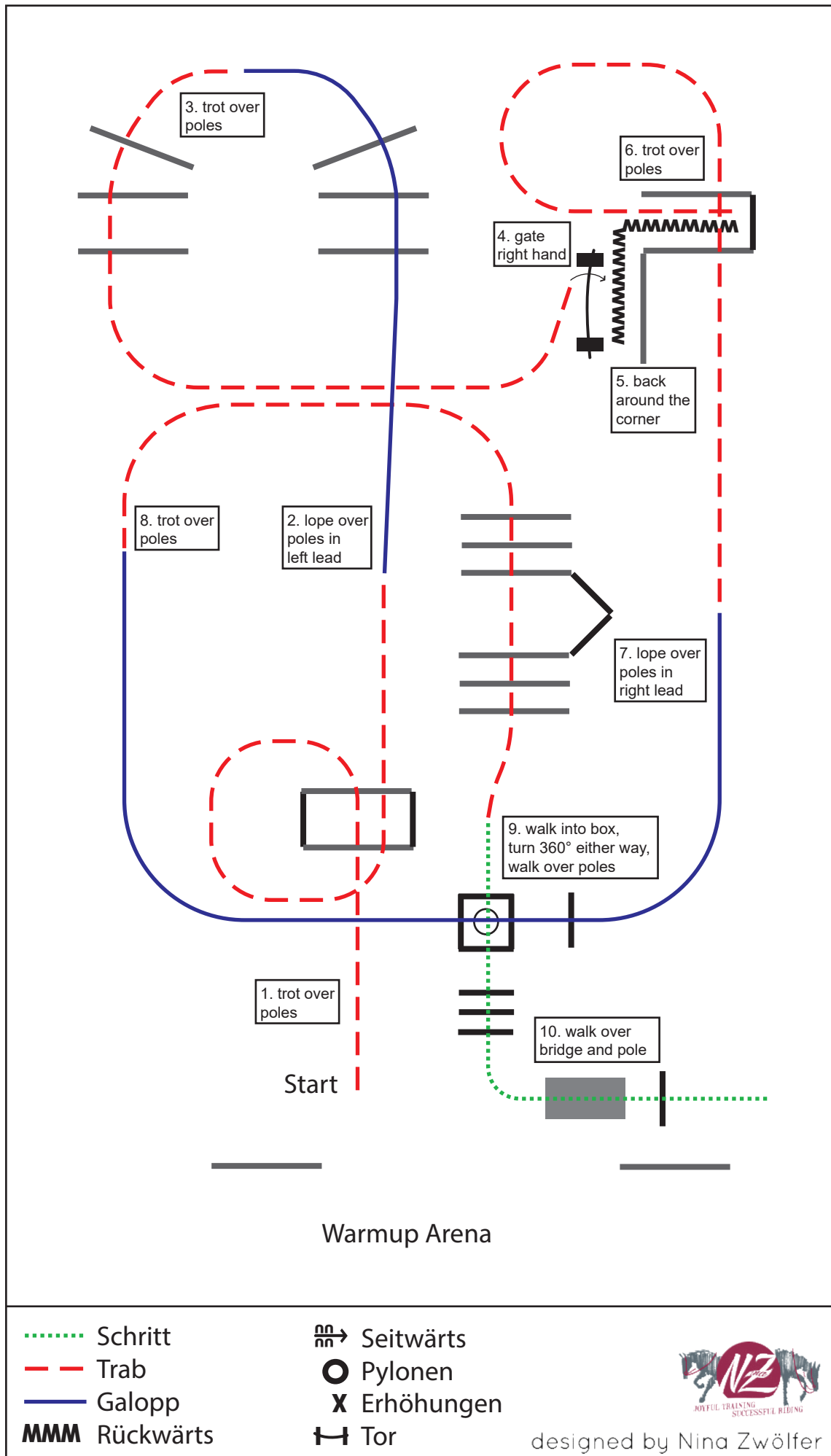



CWN-C ZNS/ARHA WTC Wr. Neustadt/NÖ - 30.4 - 02.5.2021  
 Bewerb 29 1380 O Trail + 31 1380 O Trail B LM Vorlauf

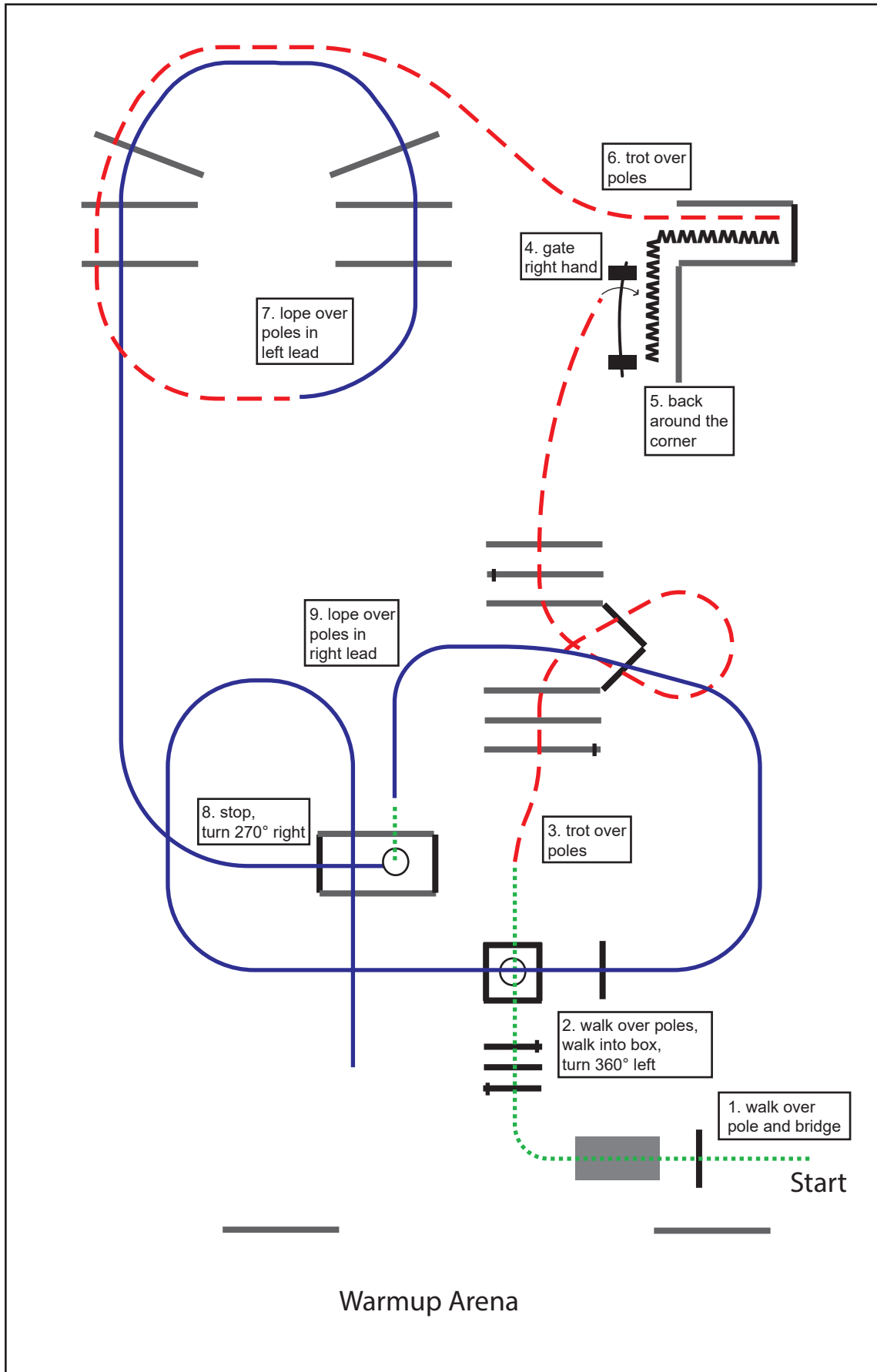

..... Schritt

- - - - - Trab

———— Galopp

**MMM** Rückwärts

↗↘ Seitwärts

○ Pylonen

X Erhöhungen

⊥ Tor



designed by Nina Zwölfer

CWN-C ZNS/ARHA WTC Wr. Neustadt/NÖ - 30.4 - 02.5.2021  
 Bewerb 30 1380 O Trail Sen M Vorlauf

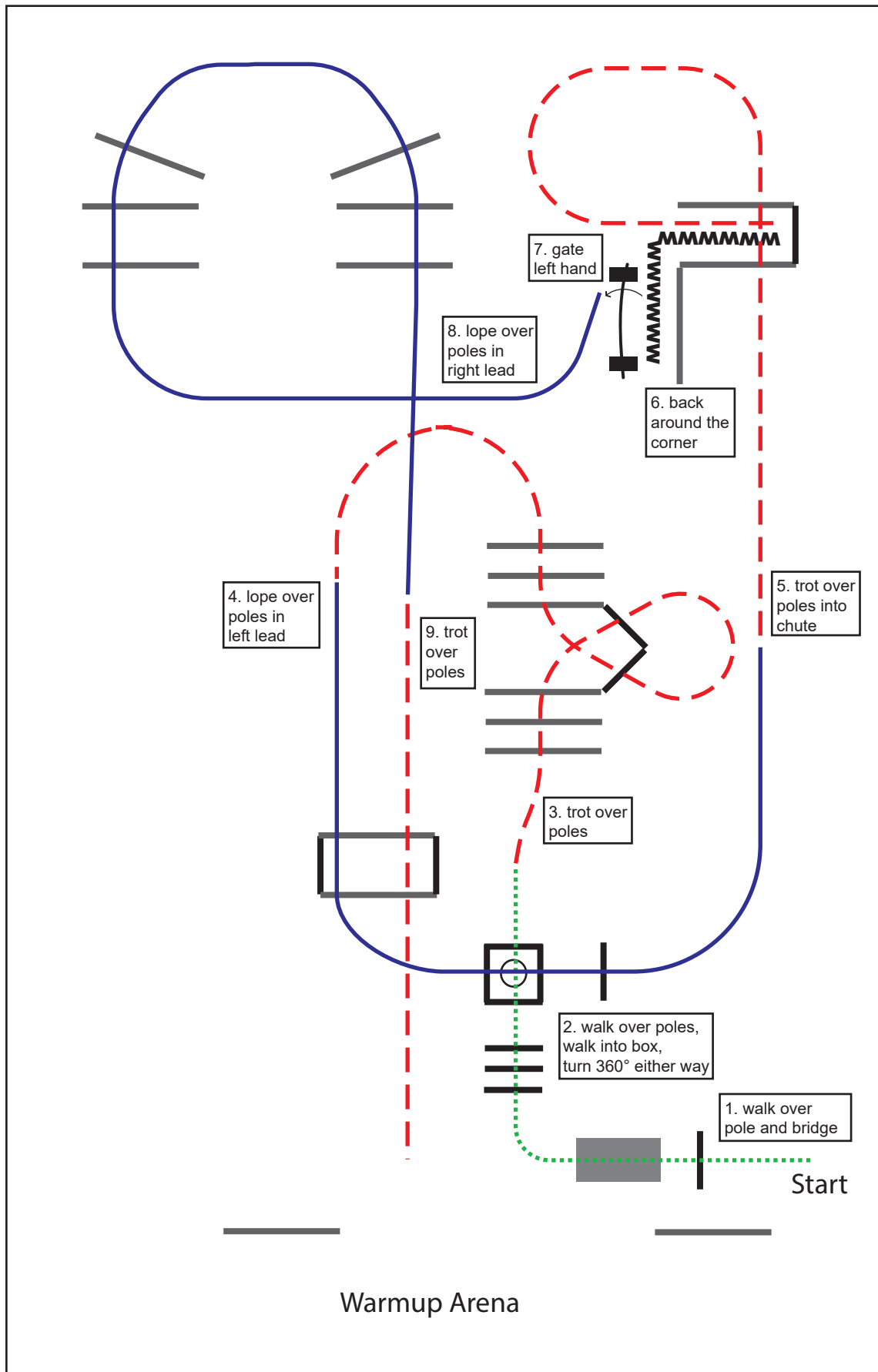

- ..... Schritt
- - - - - Trab
- Galopp
- MMM Rückwärts
- ↔ Seitwärts
- Pylonen
- X Erhöhungen
- ⊢ Tor



designed by Nina Zwölfer

CWN-C ZNS/ARHA WTC Wr. Neustadt/NÖ - 30.4 - 02.5.2021  
 Bewerb 32 8383 K Kids & 33 Youngster Trail

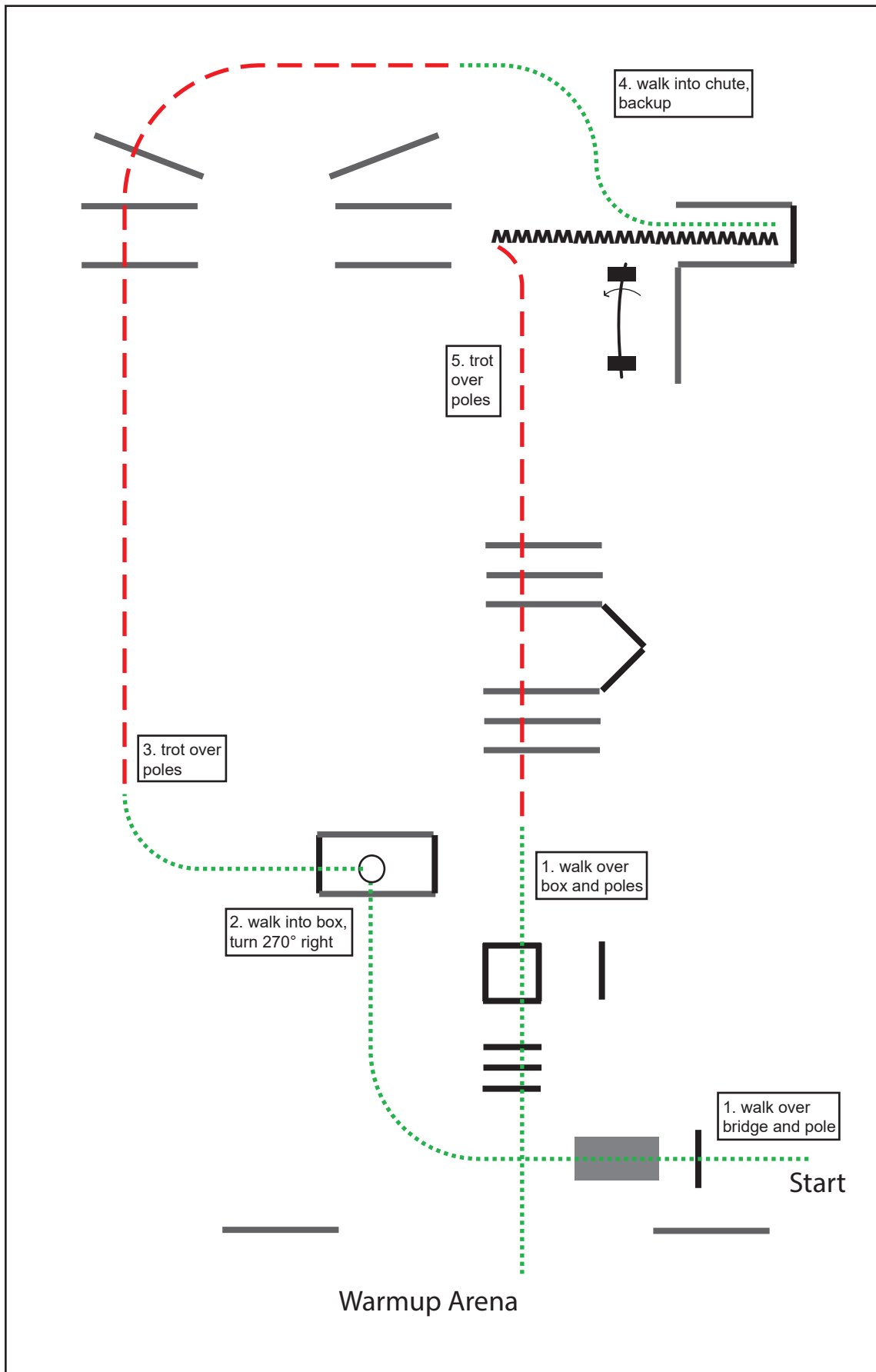

- ..... Schritt
- - - - - Trab
- Galopp
- MMM Rückwärts
- ↔ Seitwärts
- Pylonen
- X Erhöhungen
- ⊢ Tor



designed by Nina Zwölfer

CWN-C ZNS/ARHA WTC Wr. Neustadt/NÖ - 30.4 - 02.5.2021  
 Bewerb 58 8380 Y Trail B LM Youth AA Cup

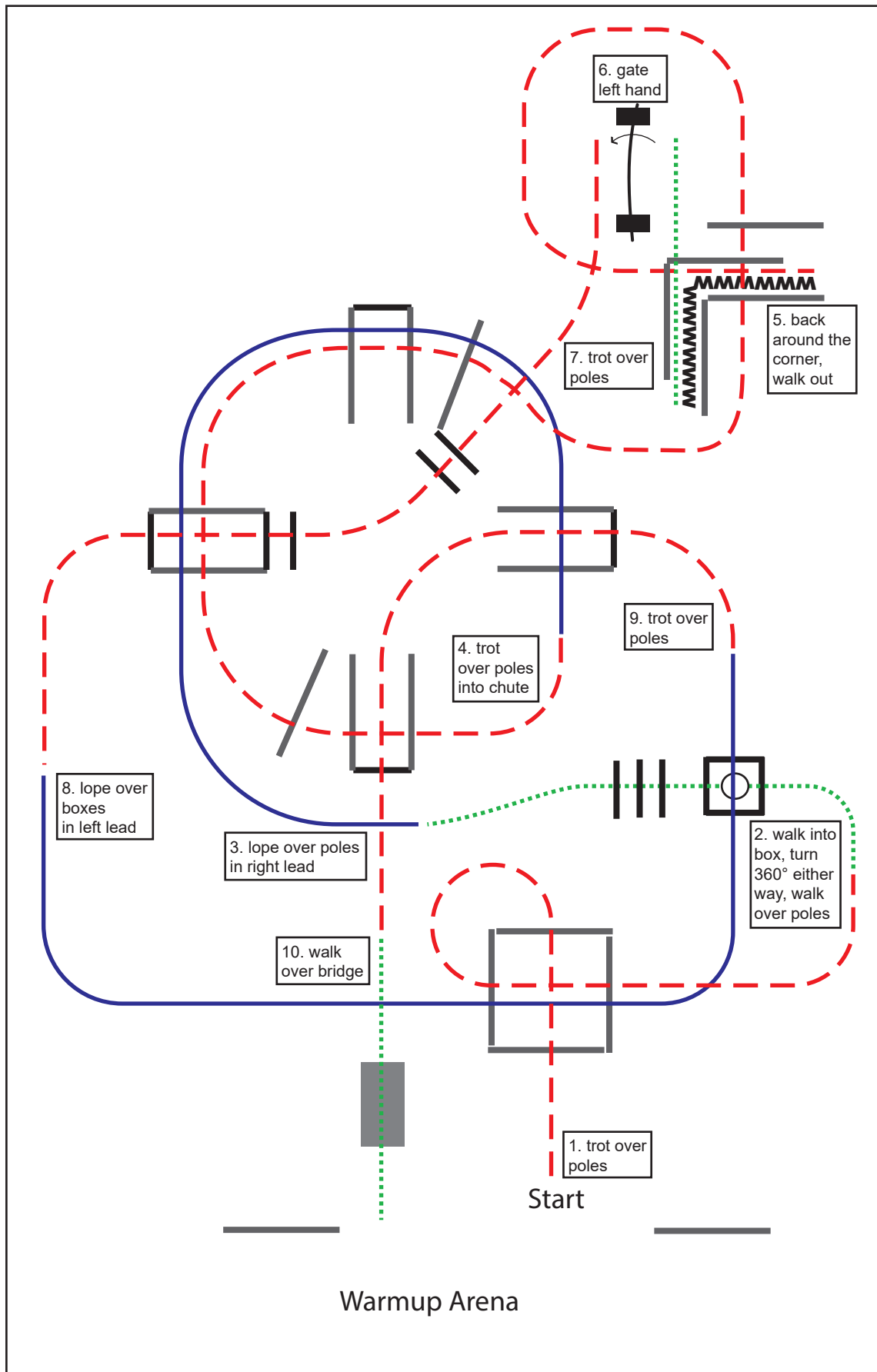

- |               |              |
|---------------|--------------|
| ..... Schritt | ↔ Seitwärts  |
| - - - Trab    | ○ Pylonen    |
| — Galopp      | X Erhöhungen |
| MMM Rückwärts | ⌋ Tor        |



designed by Nina Zwölfer

CWN-C ZNS/ARHA WTC Wr. Neustadt/NÖ - 30.4 - 02.5.2021  
 Bewerb 59 3380 NA Trail Cup

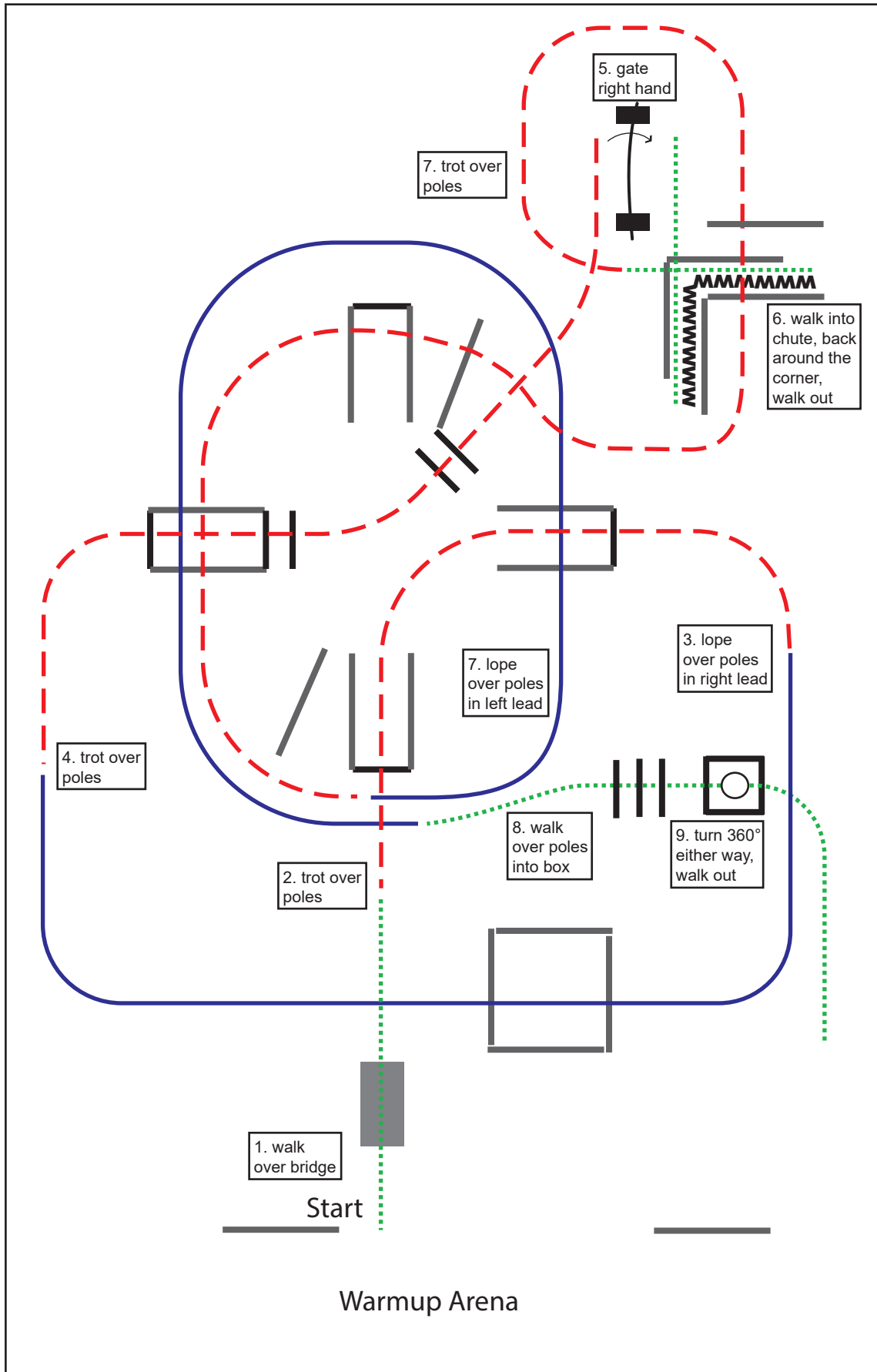

..... Schritt

- - - - - Trab

———— Galopp

**MMM** Rückwärts

Seitwärts

Pylonen

**X** Erhöhungen

Tor



designed by Nina Zwölfer

CWN-C ZNS/ARHA WTC Wr. Neustadt/NÖ - 30.4 - 02.5.2021  
 Bewerb 60 2380 A Trail Cup/AA

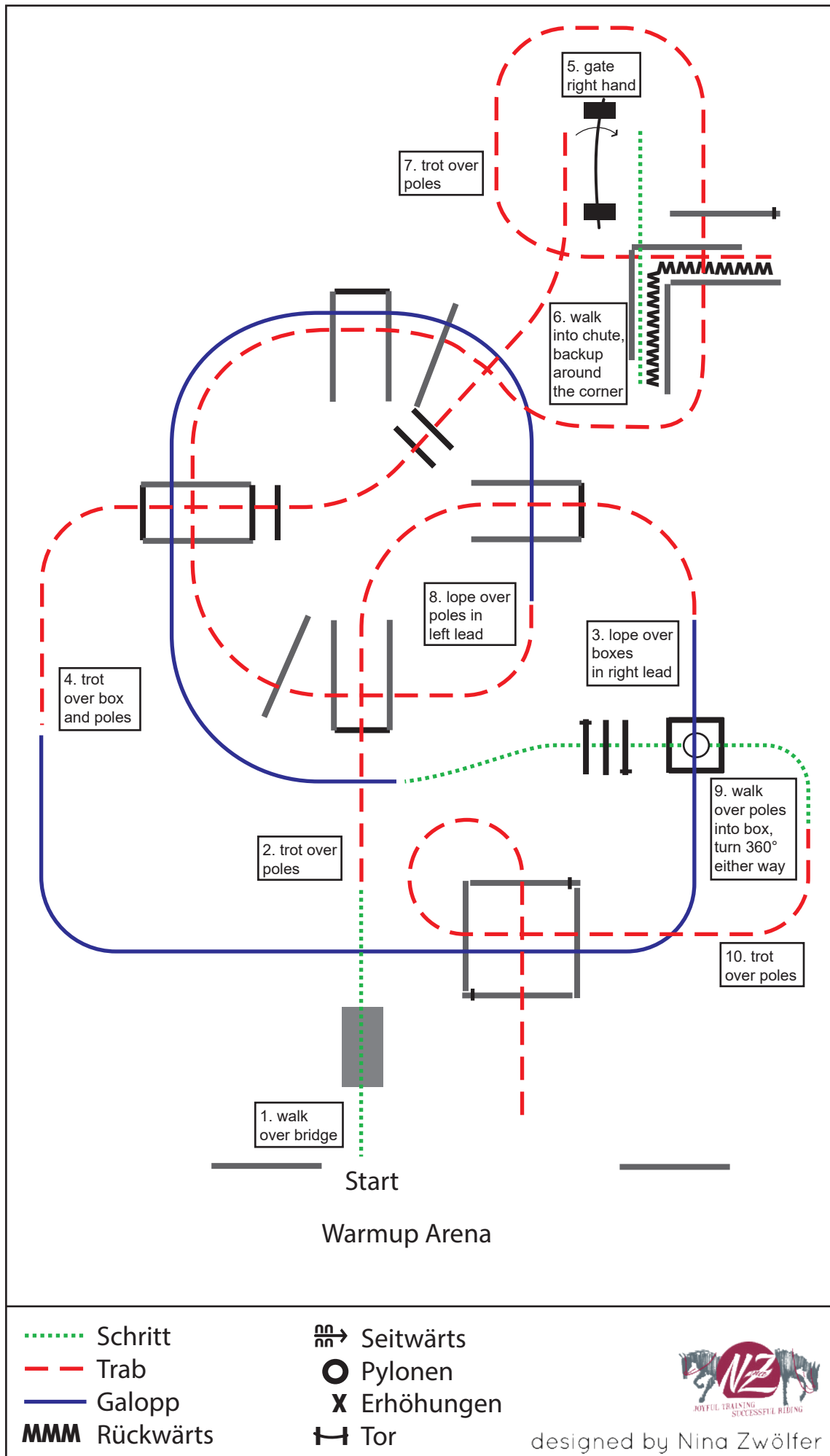

CWN-C ZNS/ARHA WTC Wr. Neustadt/NÖ - 30.4 - 02.5.2021  
 Bewerb 61 1380 OTrail B LM Finale

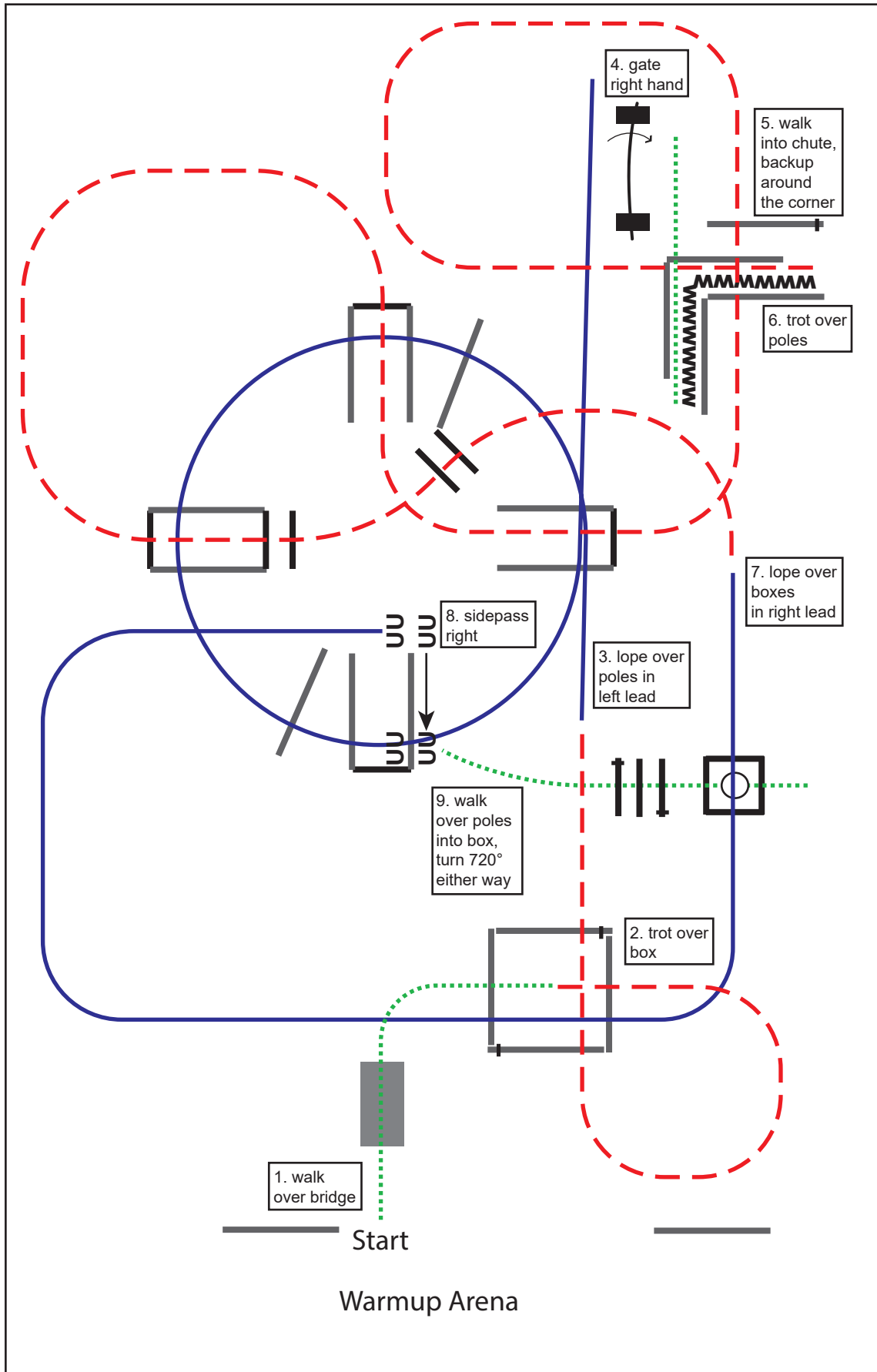

- ..... Schritt
- - - Trab
- Galopp
- MMM** Rückwärts
- $\overline{nn}$  → Seitwärts
- Pylonen
- X Erhöhungen
- ⌋ Tor



designed by Nina Zwölfer

CWN-C ZNS/ARHA WTC Wr. Neustadt/NÖ - 30.4 - 02.5.2021  
 Bewerb 62 1380 O Trail Sen. M. Finale

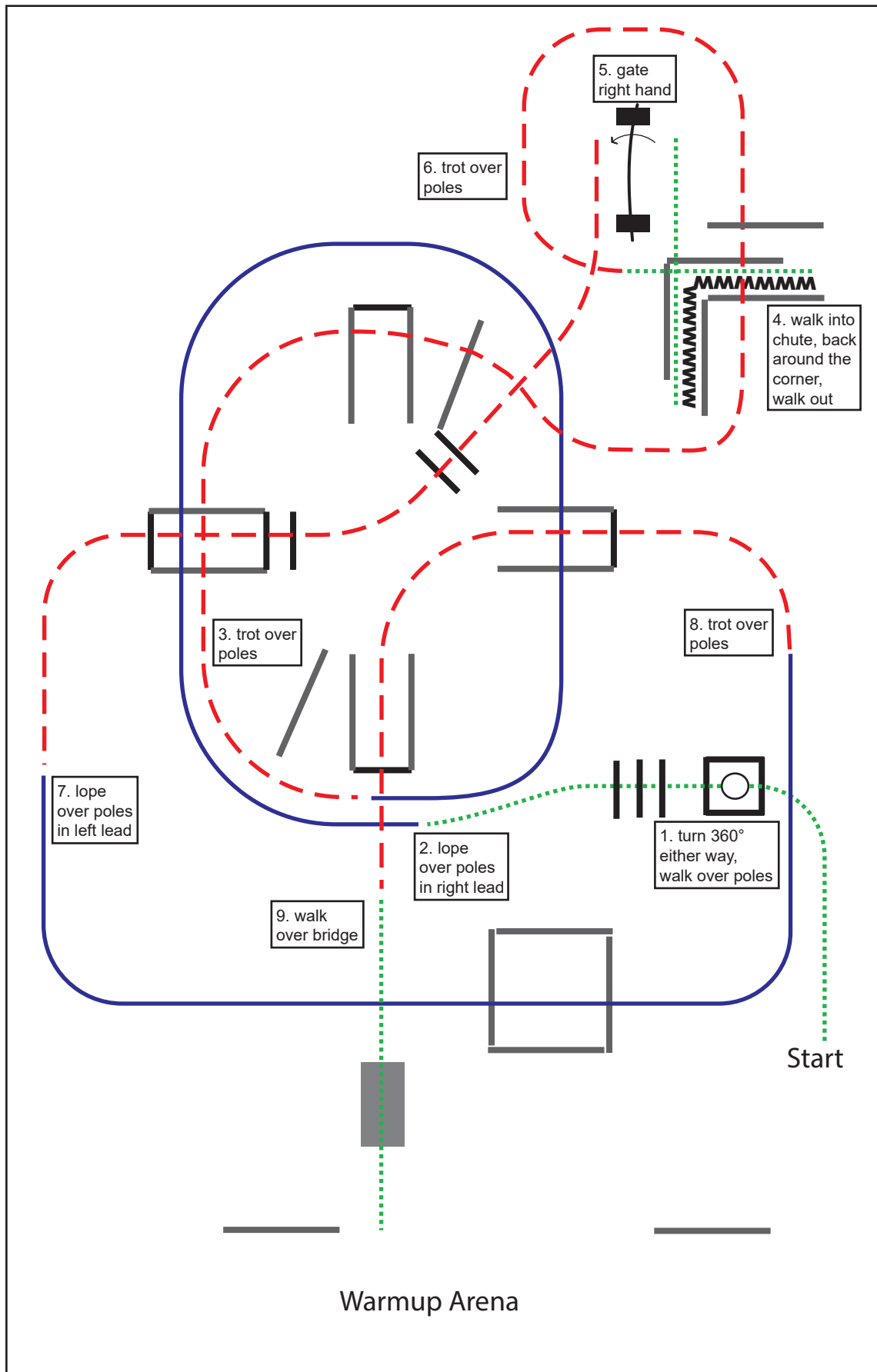

- ..... Schritt
- - - - - Trab
- Galopp
- MMM Rückwärts
- ↔ Seitwärts
- Pylonen
- X Erhöhungen
- ⌋ Tor



designed by Nina Zwölfer



CWN-C ZNS/ARHA WTC Wr. Neustadt/NÖ - 30.4 - 02.5.2021  
 Bewerb 63 1380 O Ranch Trail

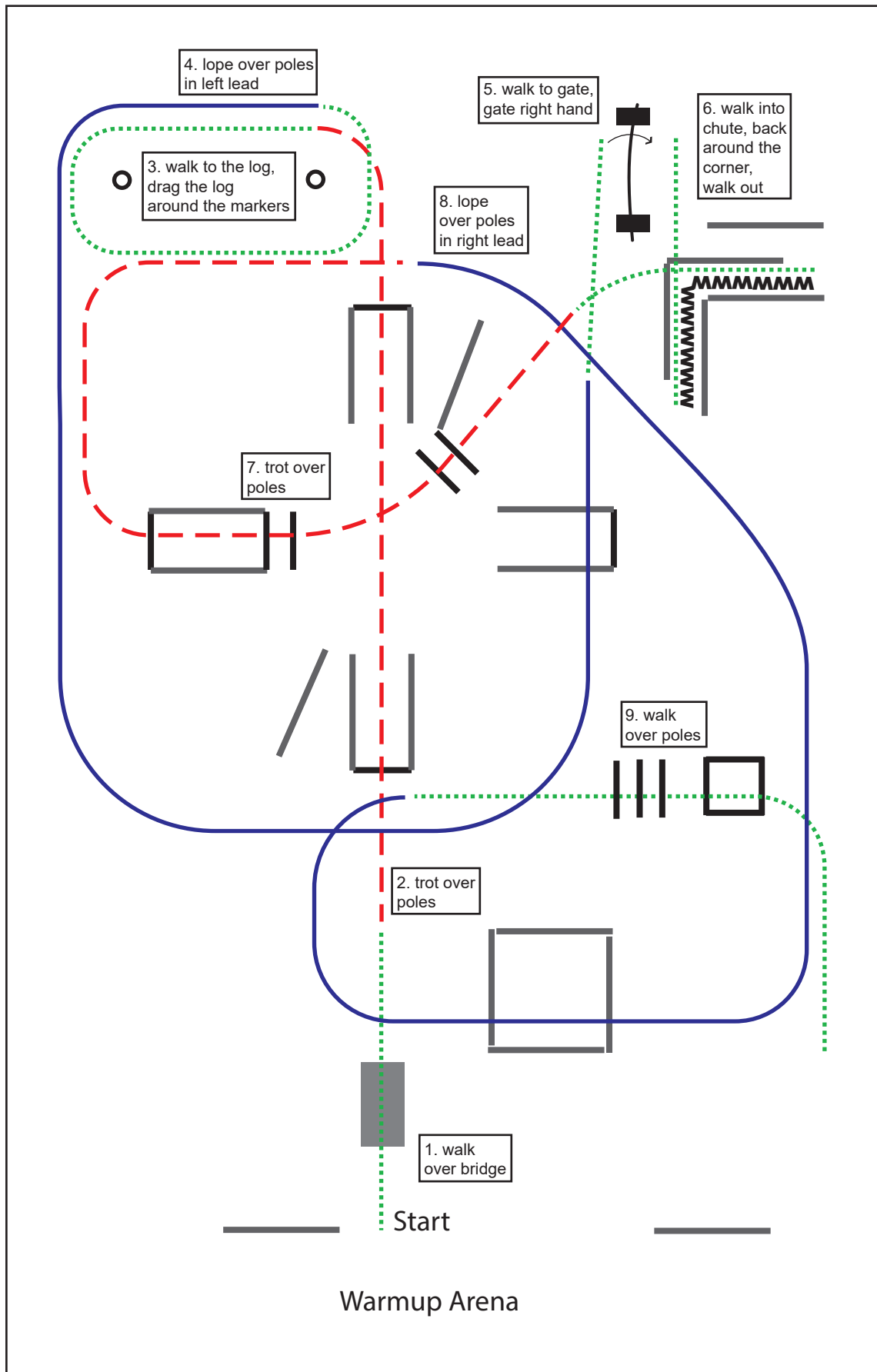

- ..... Schritt
- - - - - Trab
- Galopp
- MMM Rückwärts
- ↗↖ Seitwärts
- Pylonen
- X Erhöhungen
- H Tor



designed by Nina Zwölfer

CWN-C ZNS/ARHA WTC Wr. Neustadt/NÖ - 30.4 - 02.5.2021  
 Bewerb 64 1380 R Ranch Trail

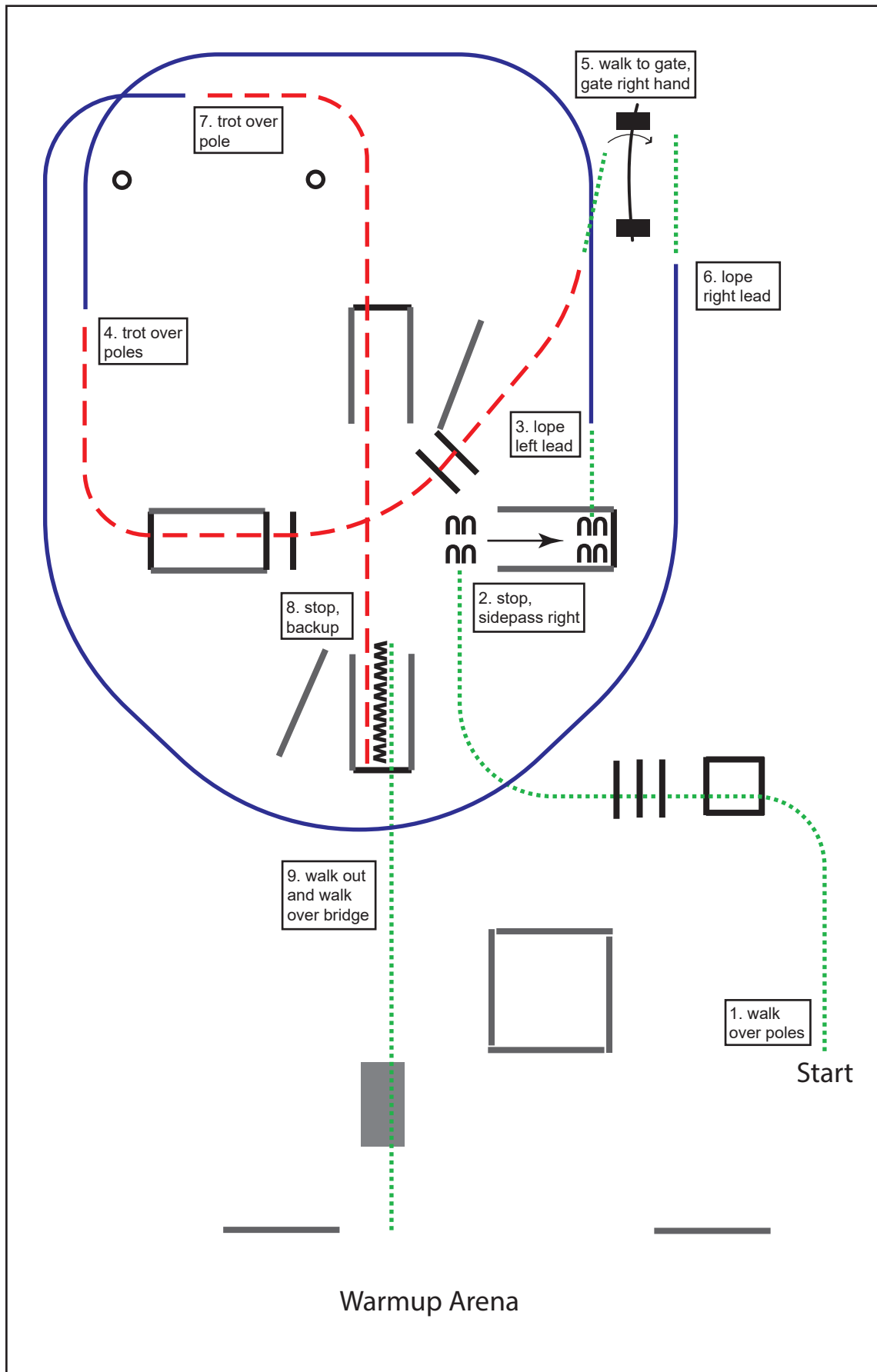

- ..... Schritt
- - - - - Trab
- Galopp
- MMM Rückwärts
- ↔ Seitwärts
- Pylonen
- X Erhöhungen
- ⊥ Tor



designed by Nina Zwölfer