

1

TRAIL IN HAND

ZIEL START

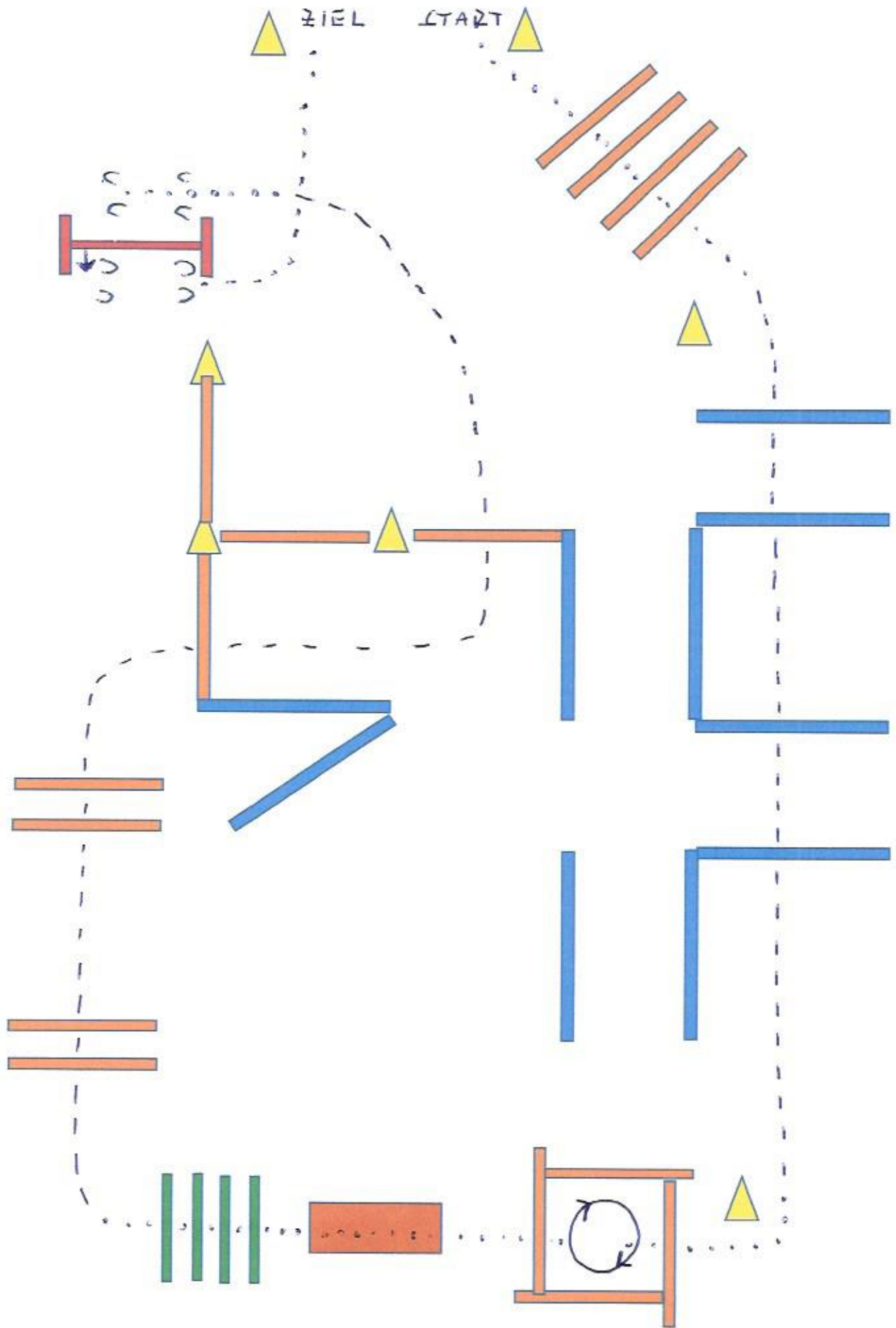

TRAIL YOUTH

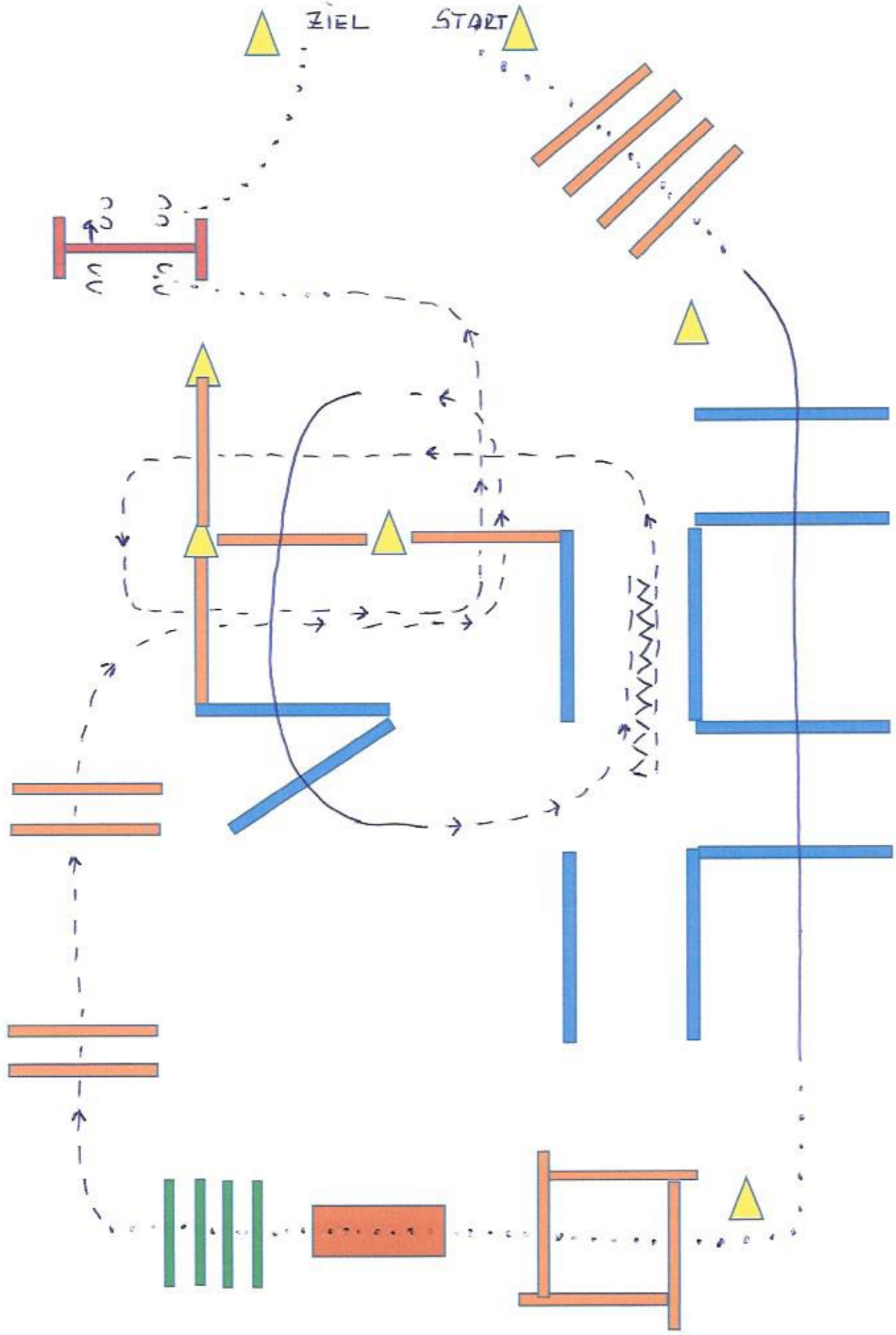

4

TRAIL OPEN

ZIEL

START

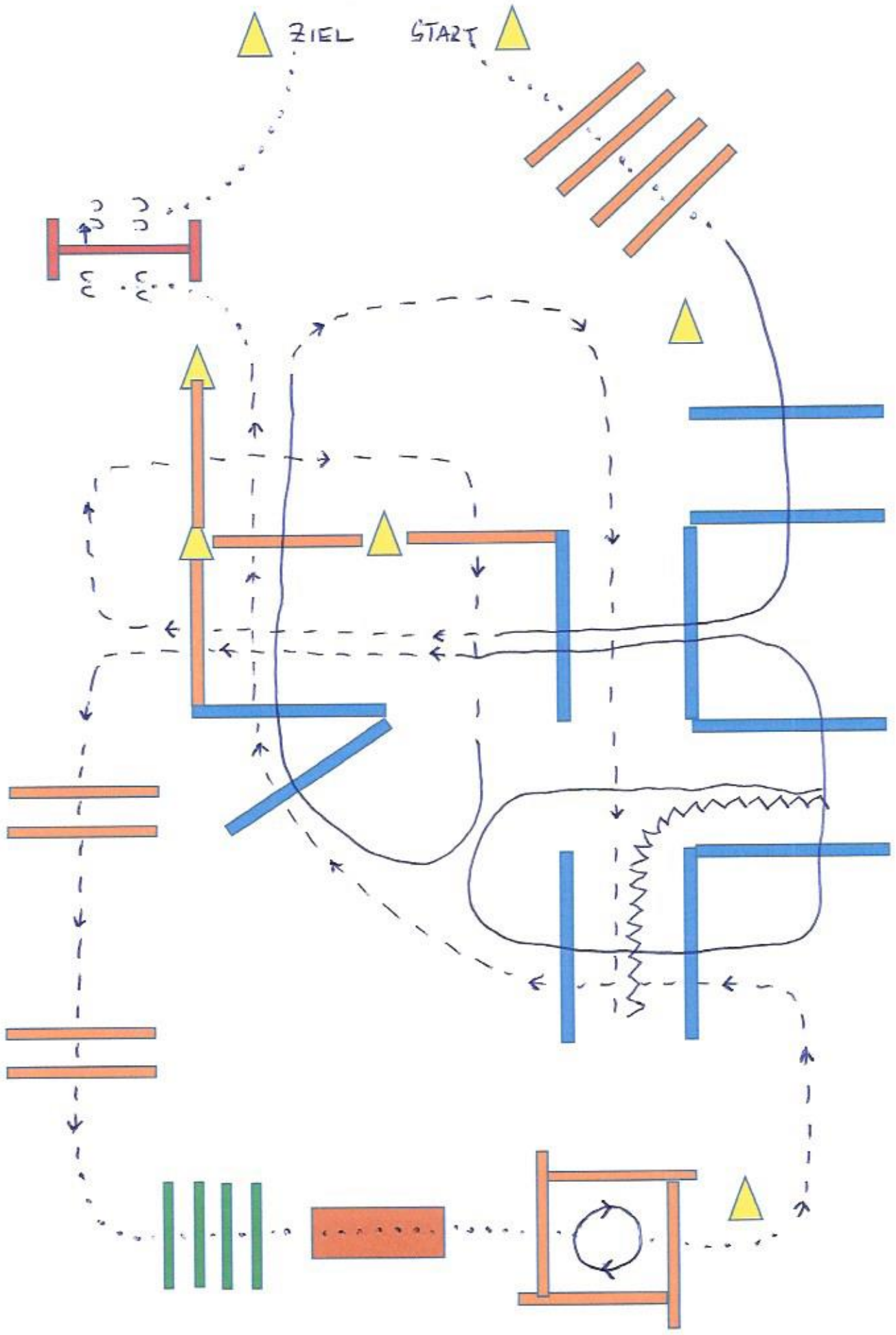

TRAIL AMATEUR

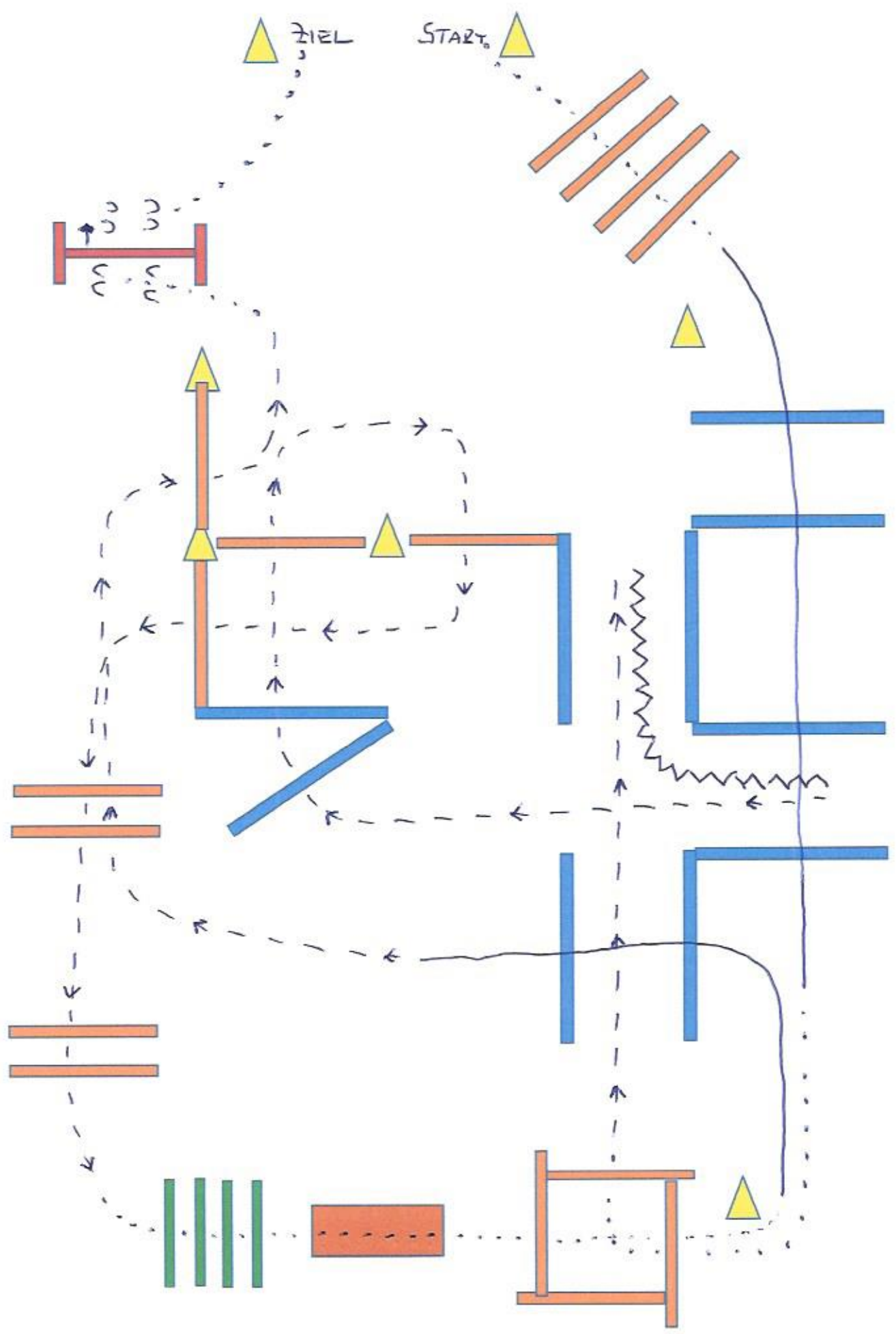

6

FÜHRZÜGEL TRAIL

ZIEL START

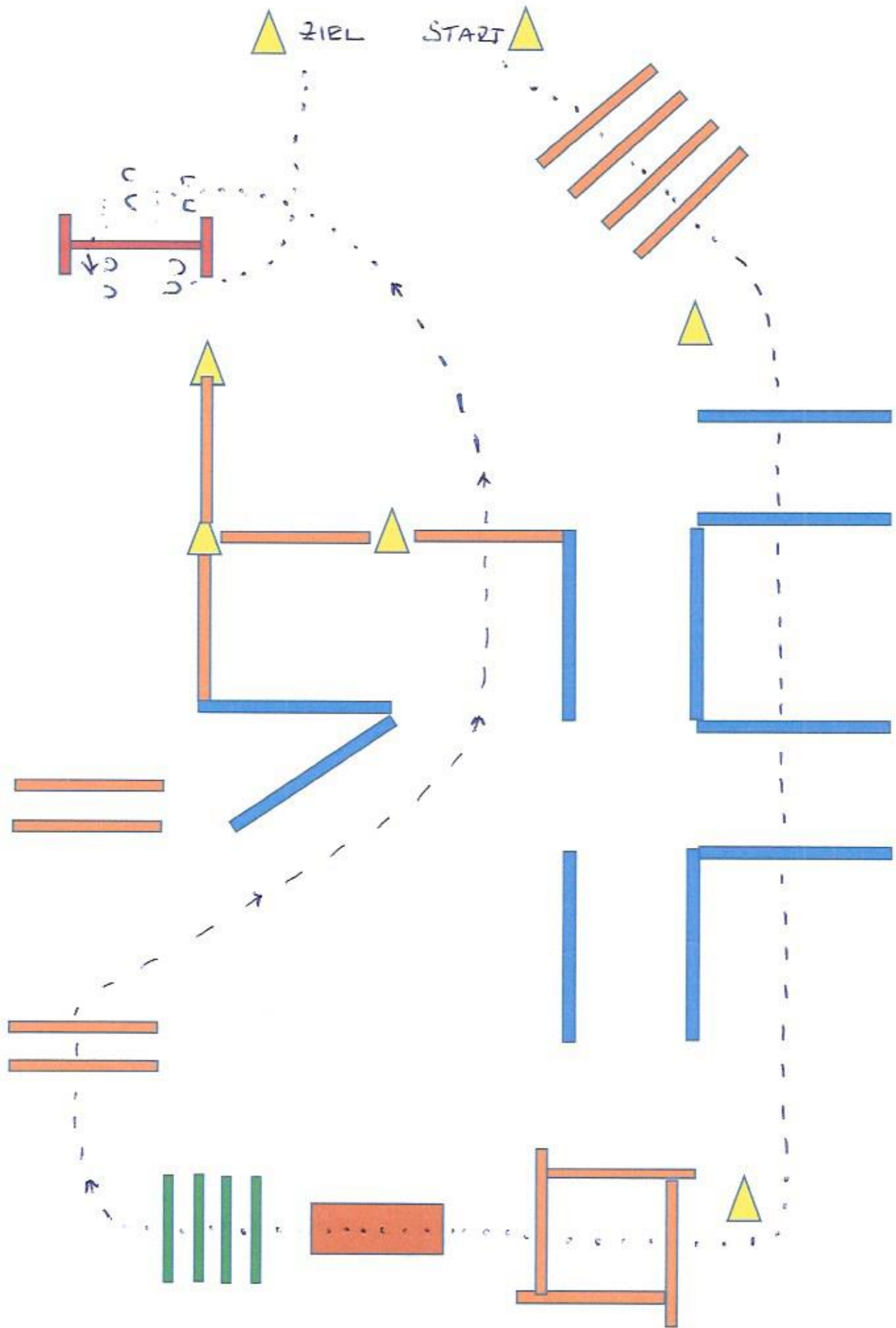

7

WALK AND TROT

ZIEL

START

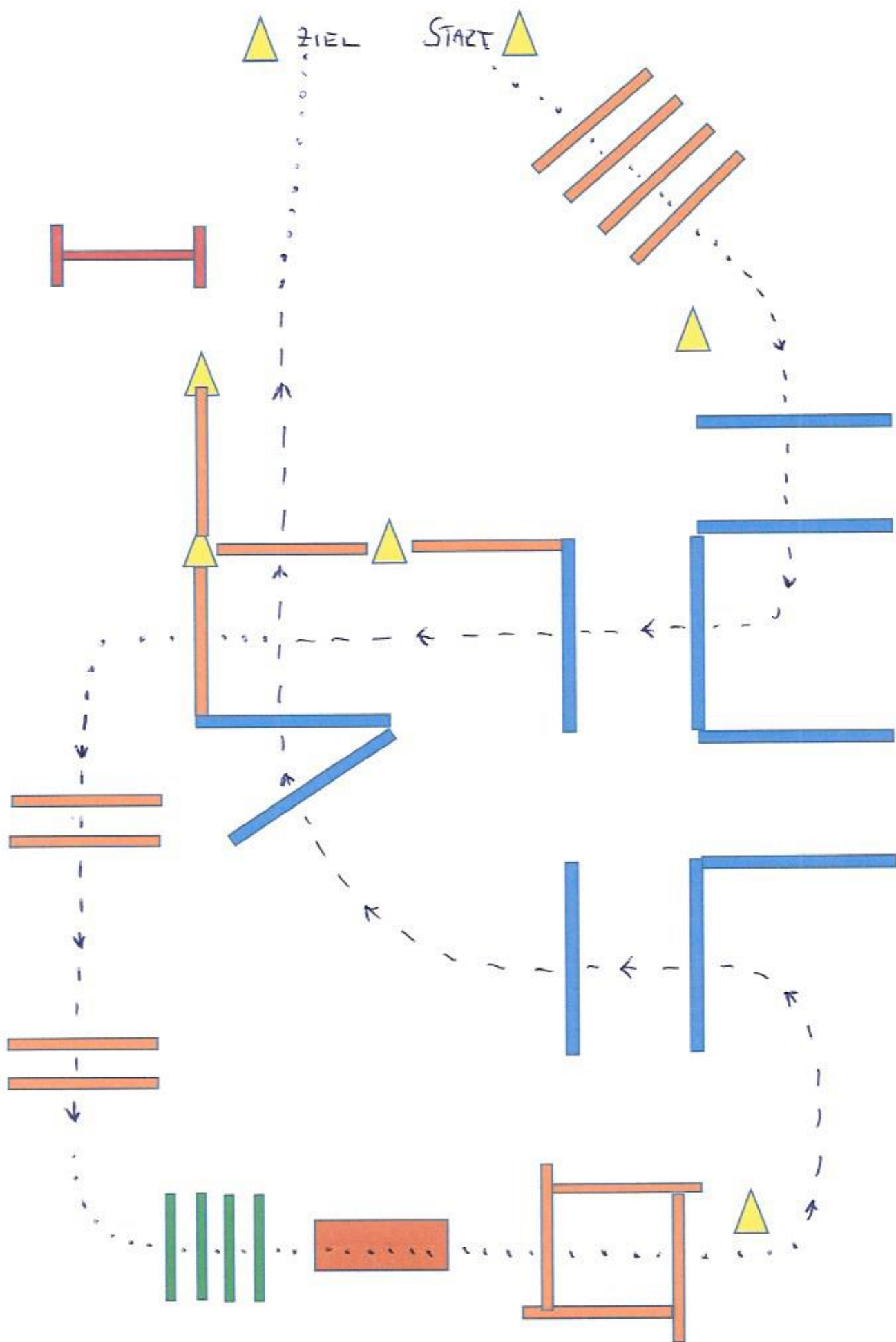

WALK AND TROT HHS

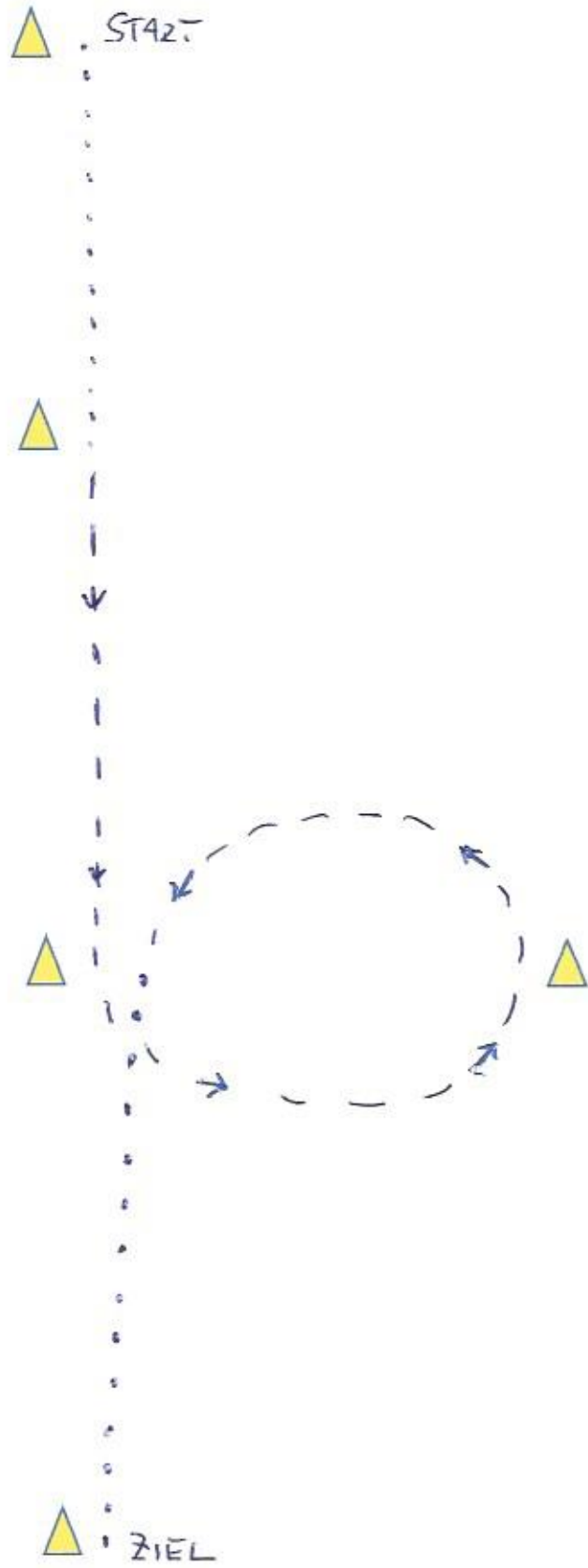

- 1 WALK
- 2 TROT
- 3 TROT ZIRKEL LINKS
- 4 WALK

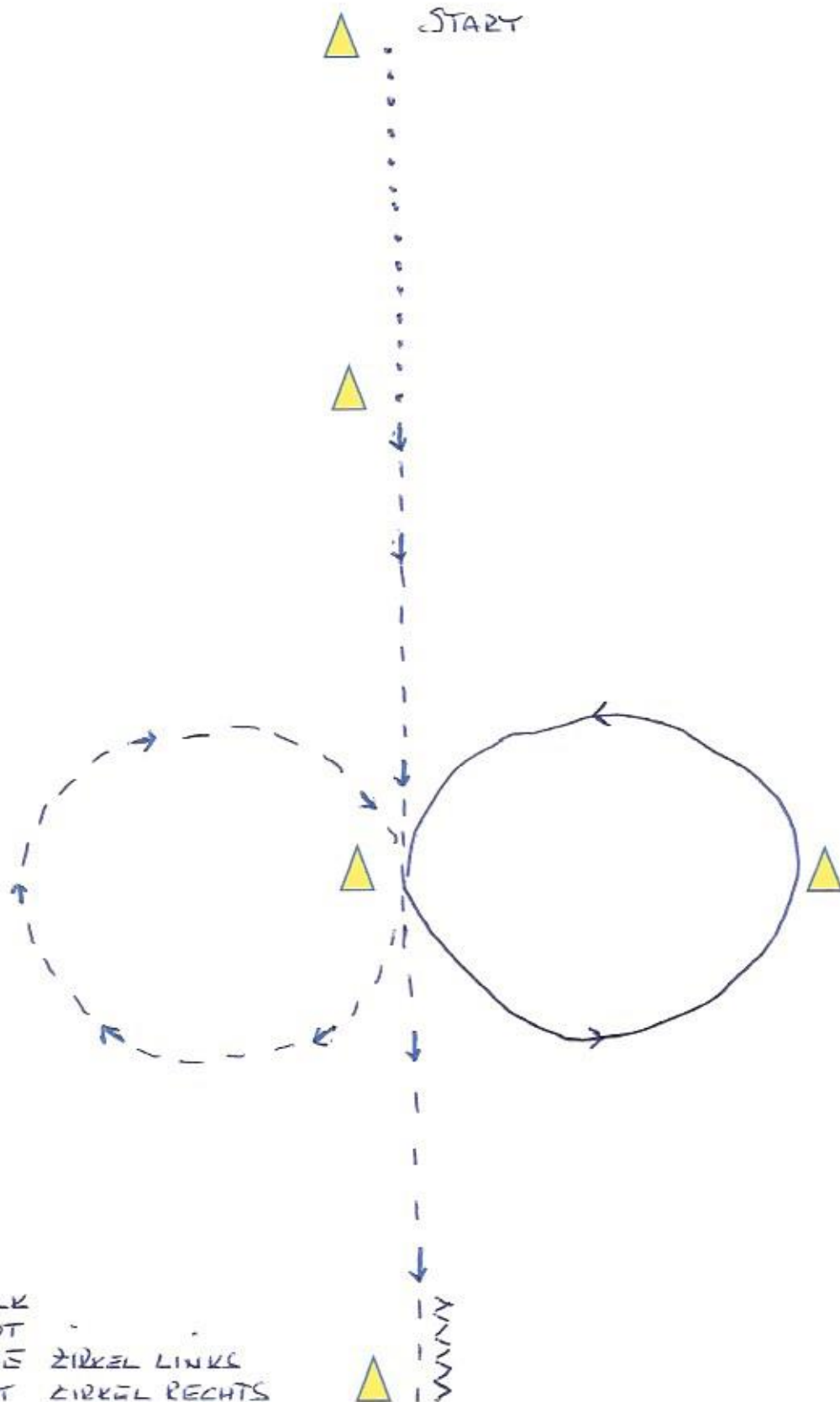

- 1 WALK
- 2 TROT
- 3 LOPE ZIRKEL LINKS
- 4 TROT ZIRKEL RECHTS
- 5 TROT STOP
- 6 BACK

12

HMS ZOOKE

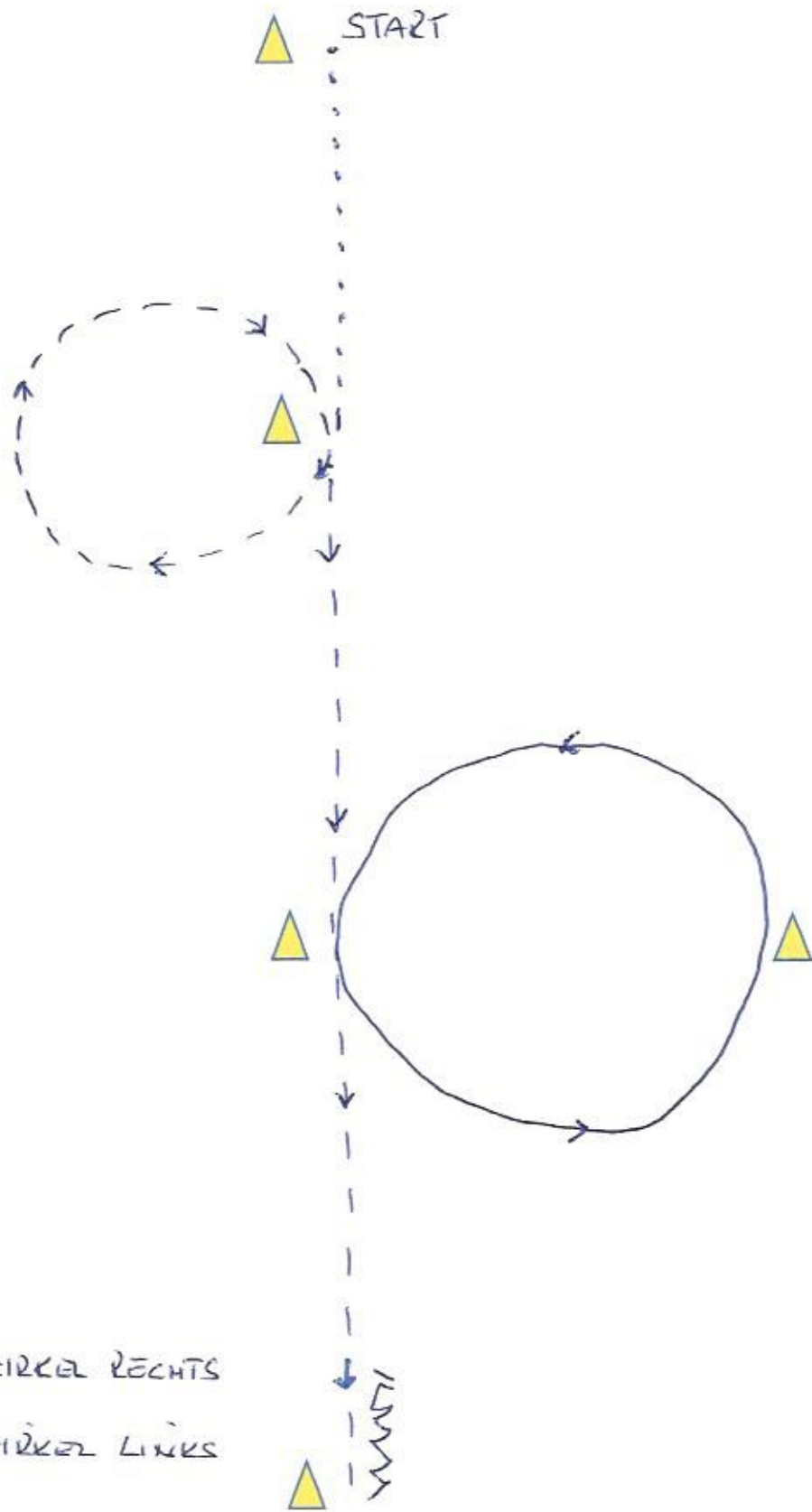

- 1 WALK
- 2 TROT
- 2 TROT ZIRKEL RECHTS
- 4 TROT
- 5 LOPE ZIRKEL LINKS
- 6 TROT
- 7 BACK

13

HMS OPEN

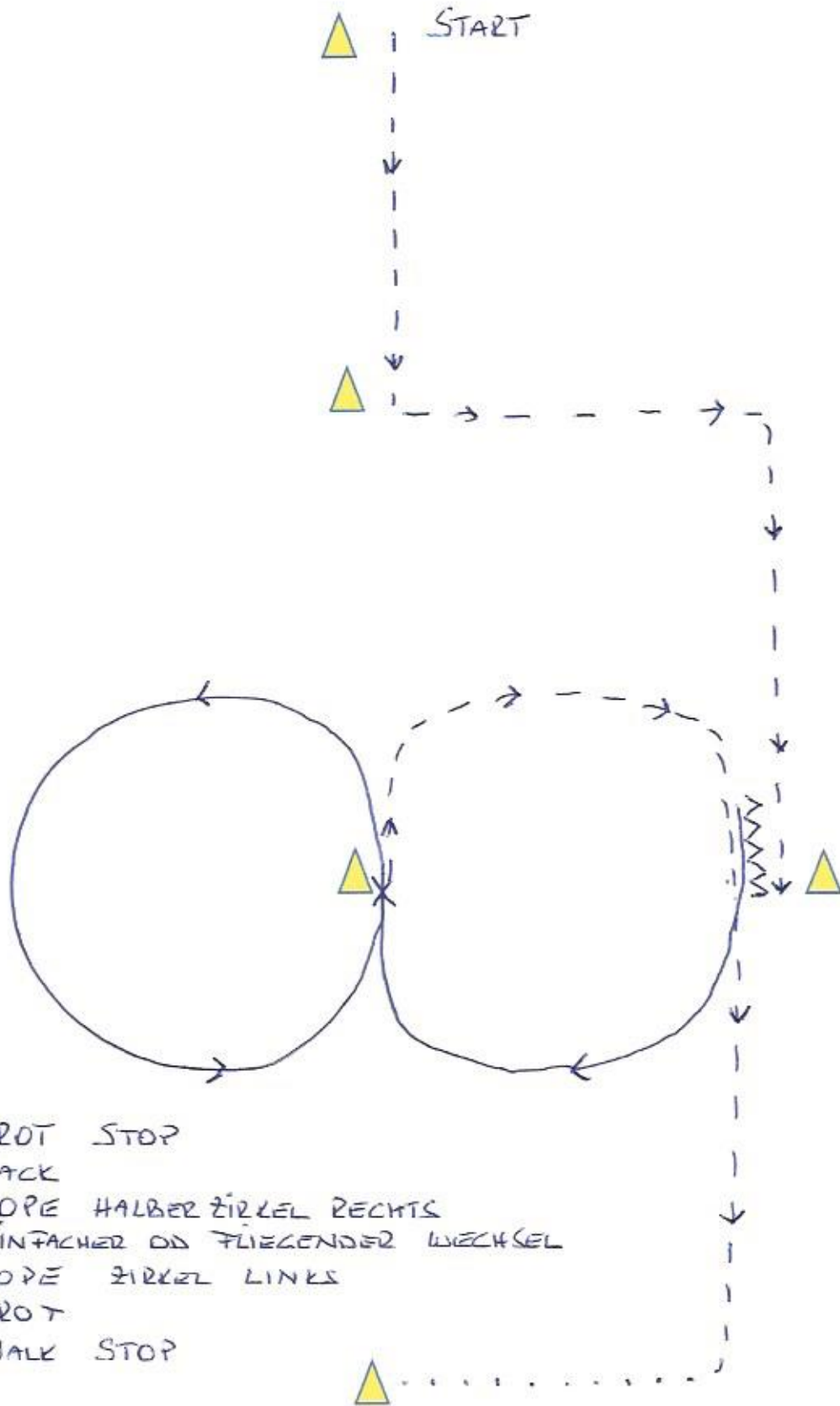

- 1 TROT STOP
- 2 BACK
- 3 LOPE HALBER ZIRKEL RECHTS
- 4 EINFACHER OD FLIEGENDER WECHSEL
- 5 LOPE ZIRKEL LINKS
- 6 TROT
- 7 WALK STOP

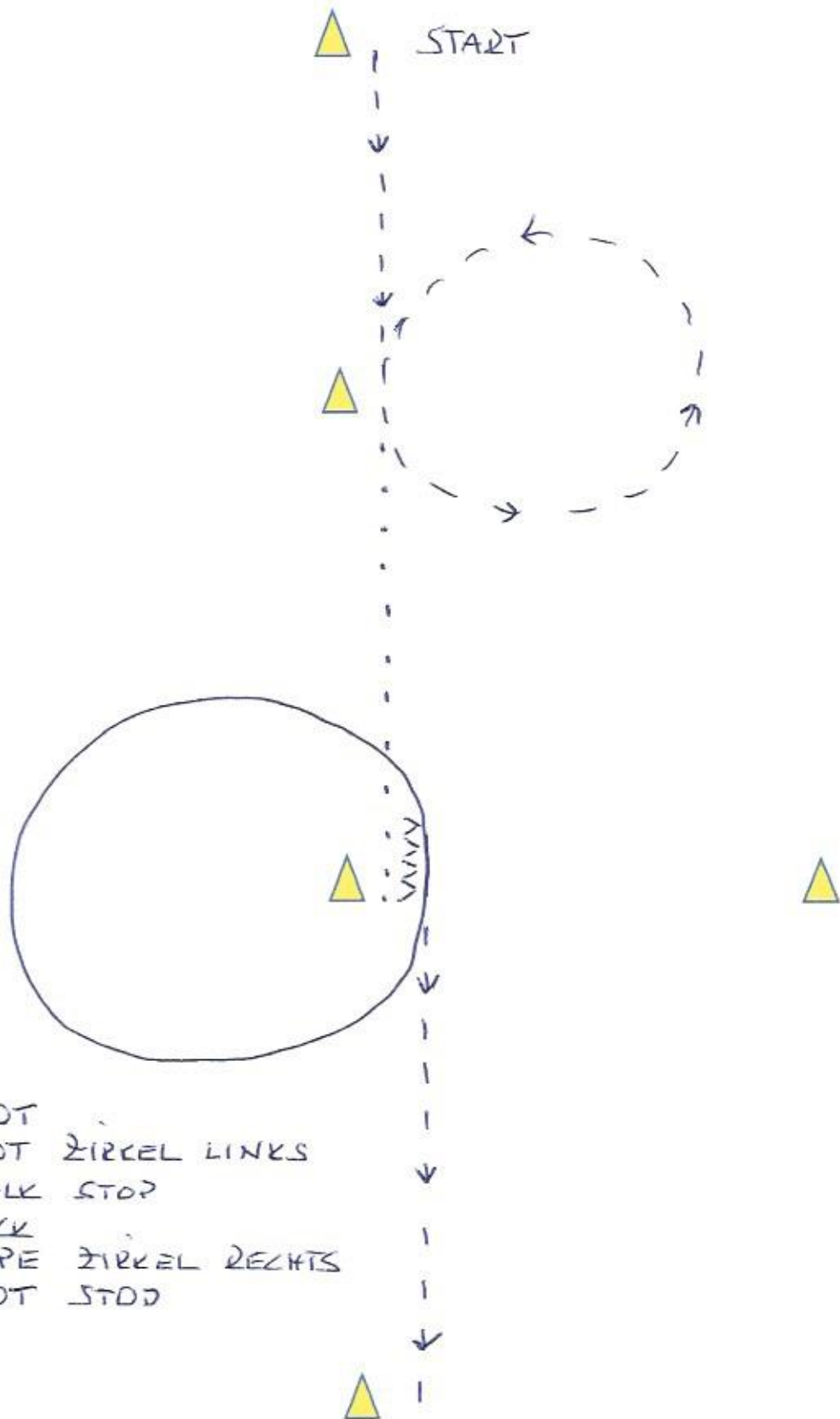

SHOWMANSHIP AT HALTER

1. TROT PAST JUDGE STOP
2. BACK 1/4 TURN RECHTS BACK
3. WALK TO JUDGE. SET UP
4. TURN 3/4. SETUP FOR BRIEF
5. FULL TURN
6. TROT, WALK, TROT $\frac{2}{3}$
7. WALK AND STOP

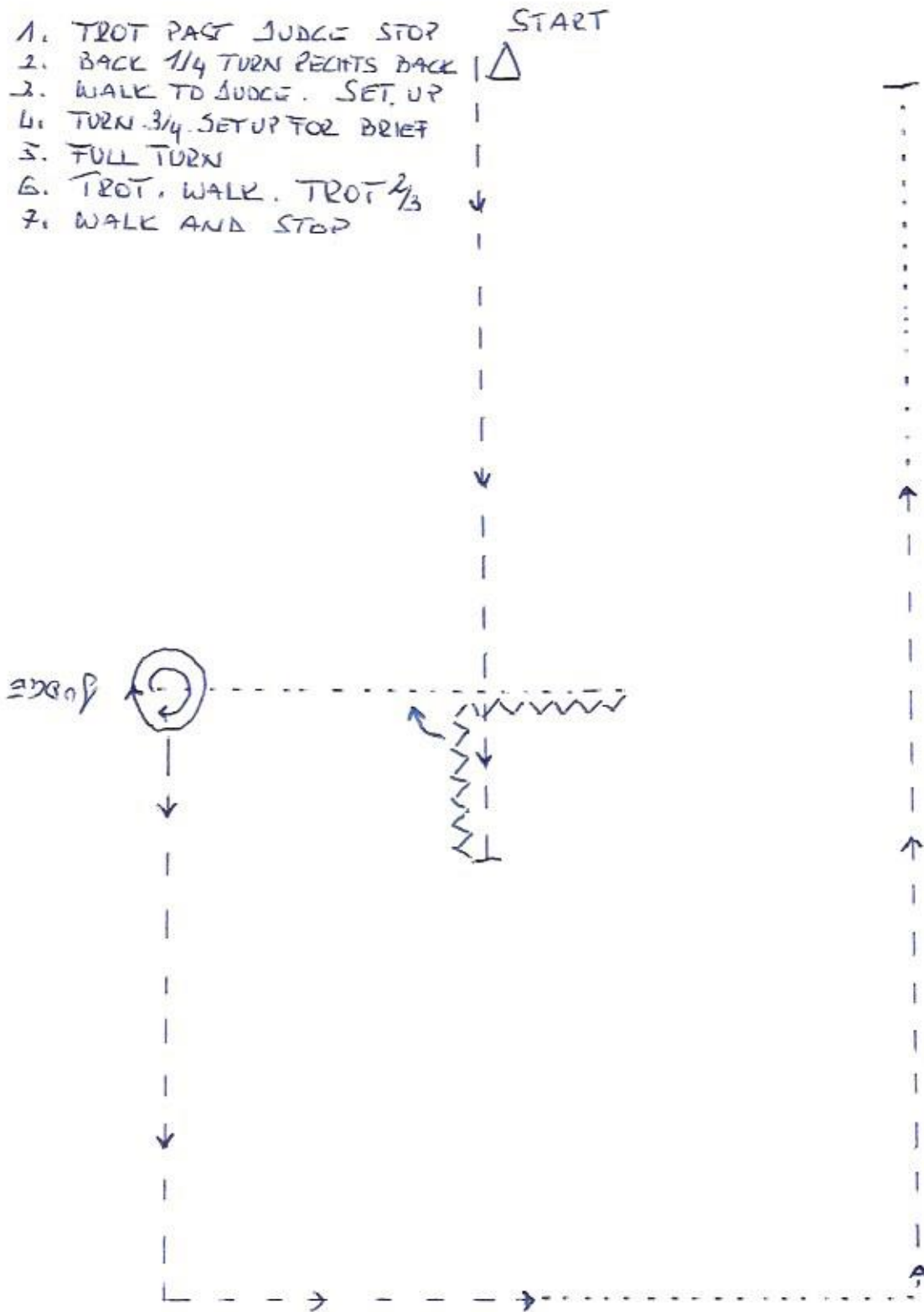

RANCH TRAIL YOUTH

START

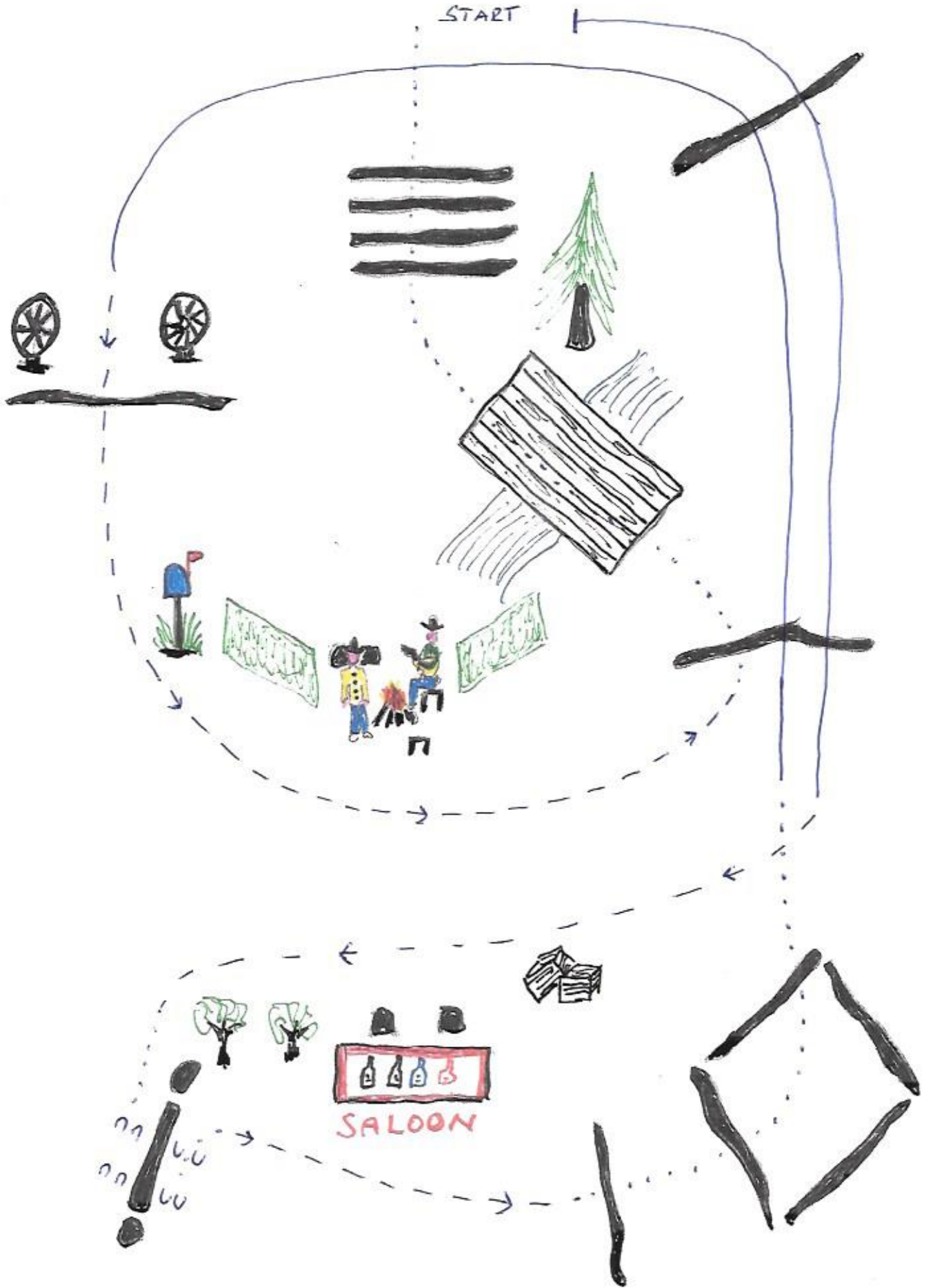

START/ZIEL

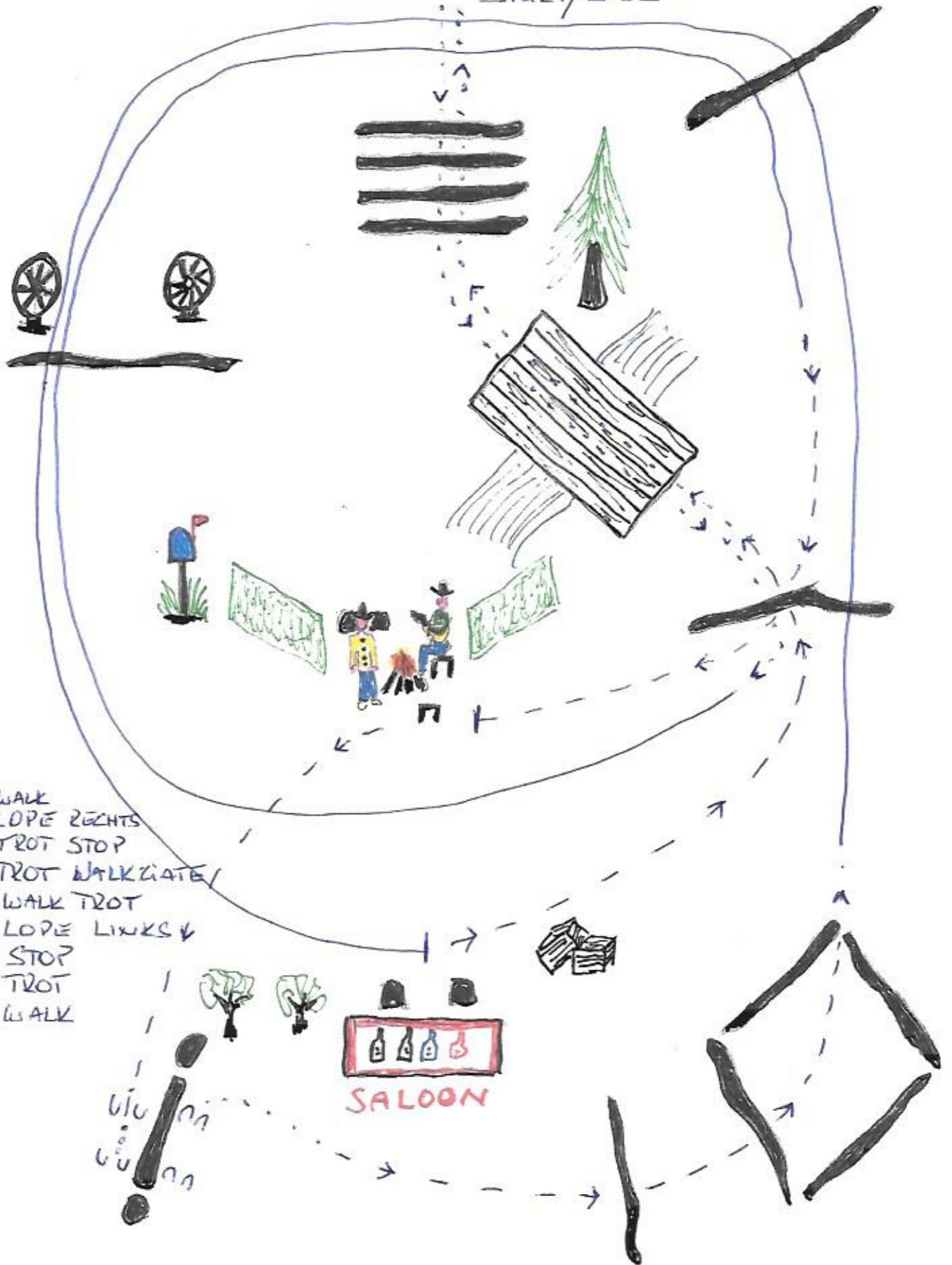

1. WALK
2. LOPE RECHTS
3. TROT STOP
4. TROT WALKZIATE/
5. WALK TROT
6. LOPE LINKS ↓
7. STOP
8. TROT
9. WALK

RANCH TRAIL AMATEUR

START ZIEL

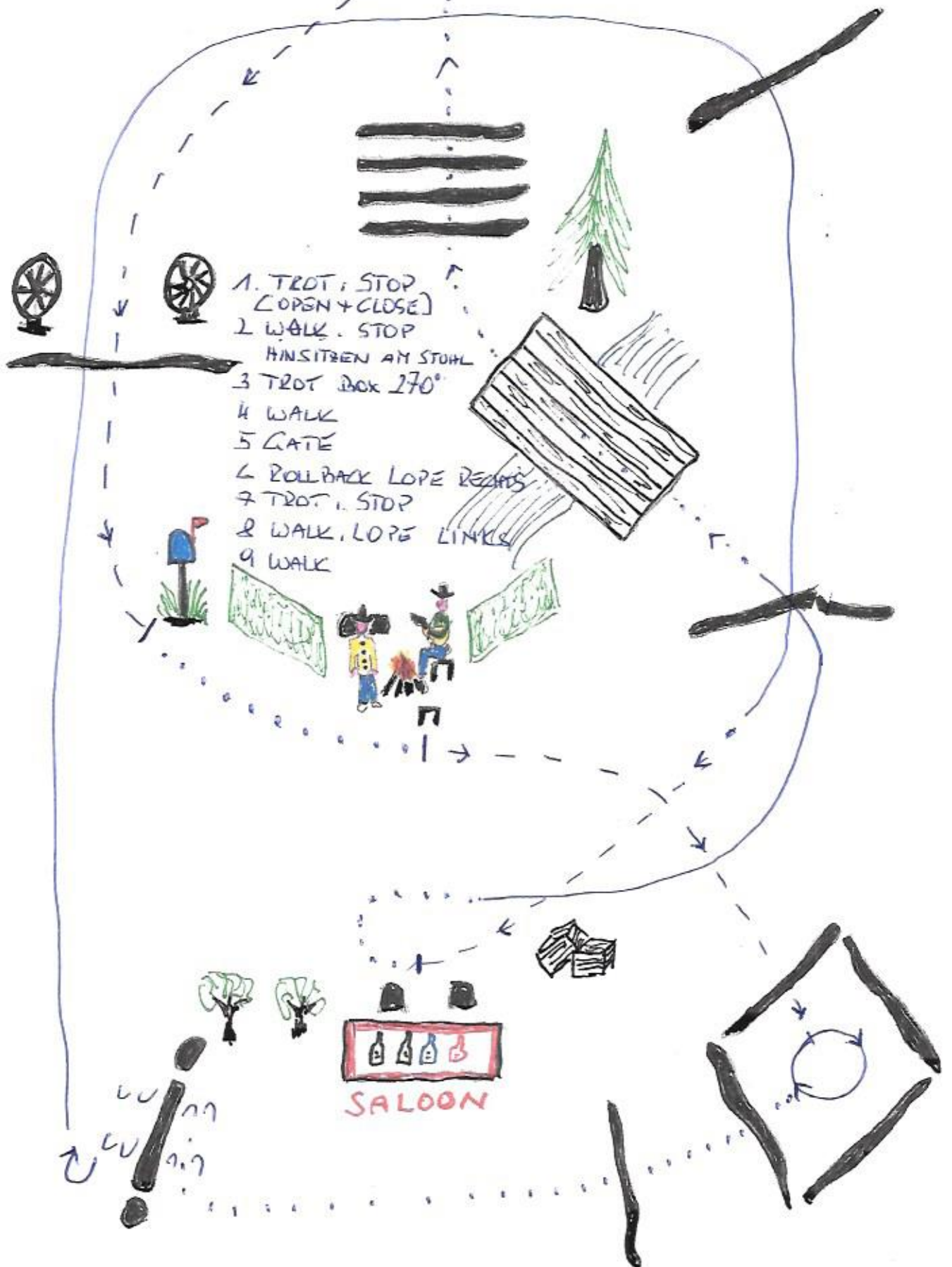

37

RANCHO TRAIL OPEN

START ZIEL

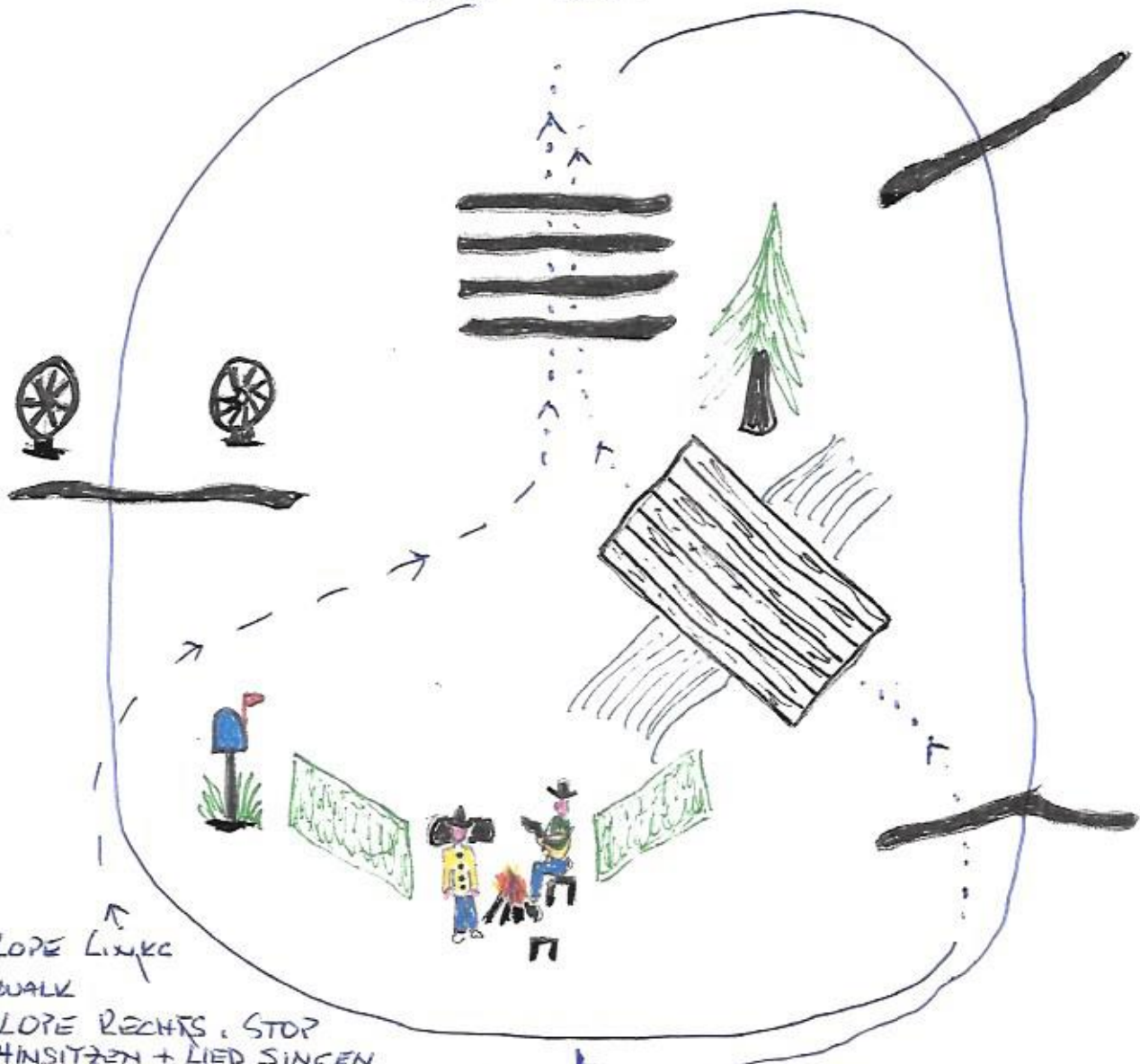

- 1 LOPE LINKS
- 2 WALK
- 3 LOPE RECHTS, STOP
HINSITZEN + LIED SINGEN
- 4 TROT, GATE
- 5 TROT, BOX 270°
- 6 WALK STOP
WISKY TRINKEN
- 7 TROT
- 8 WALK

