

CWN-C ZNS/ARHA WTC Western Star Cup 1  
 Wr. Neustadt/NÖ \* 07.04. - 09.04.2023  
 16 Horsemanship Open PT

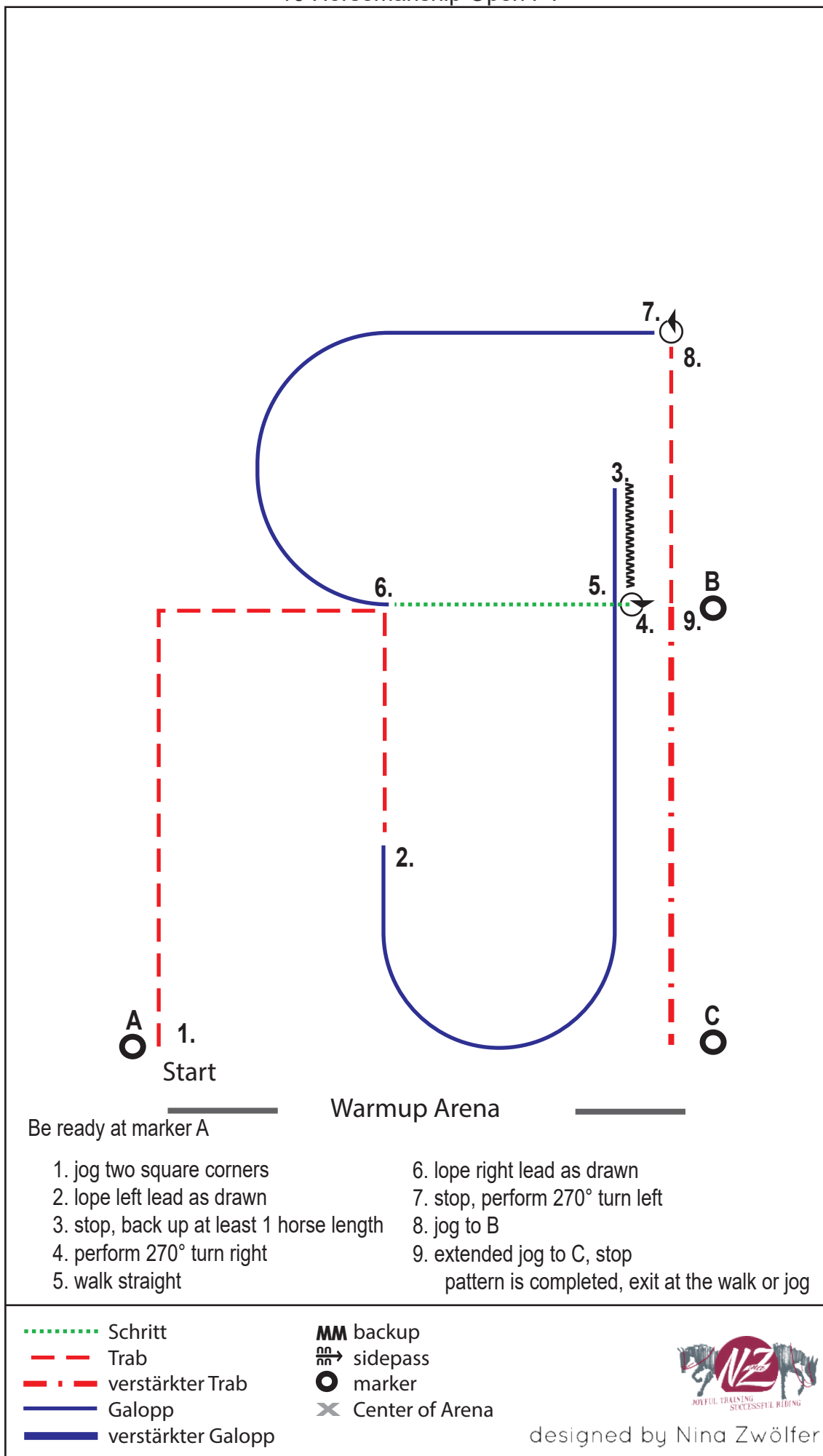

CWN-C ZNS/ARHA WTC Western Star Cup 1  
 Wr. Neustadt/NÖ \* 07.04. - 09.04.2023  
 17 Horsemanship Amateur

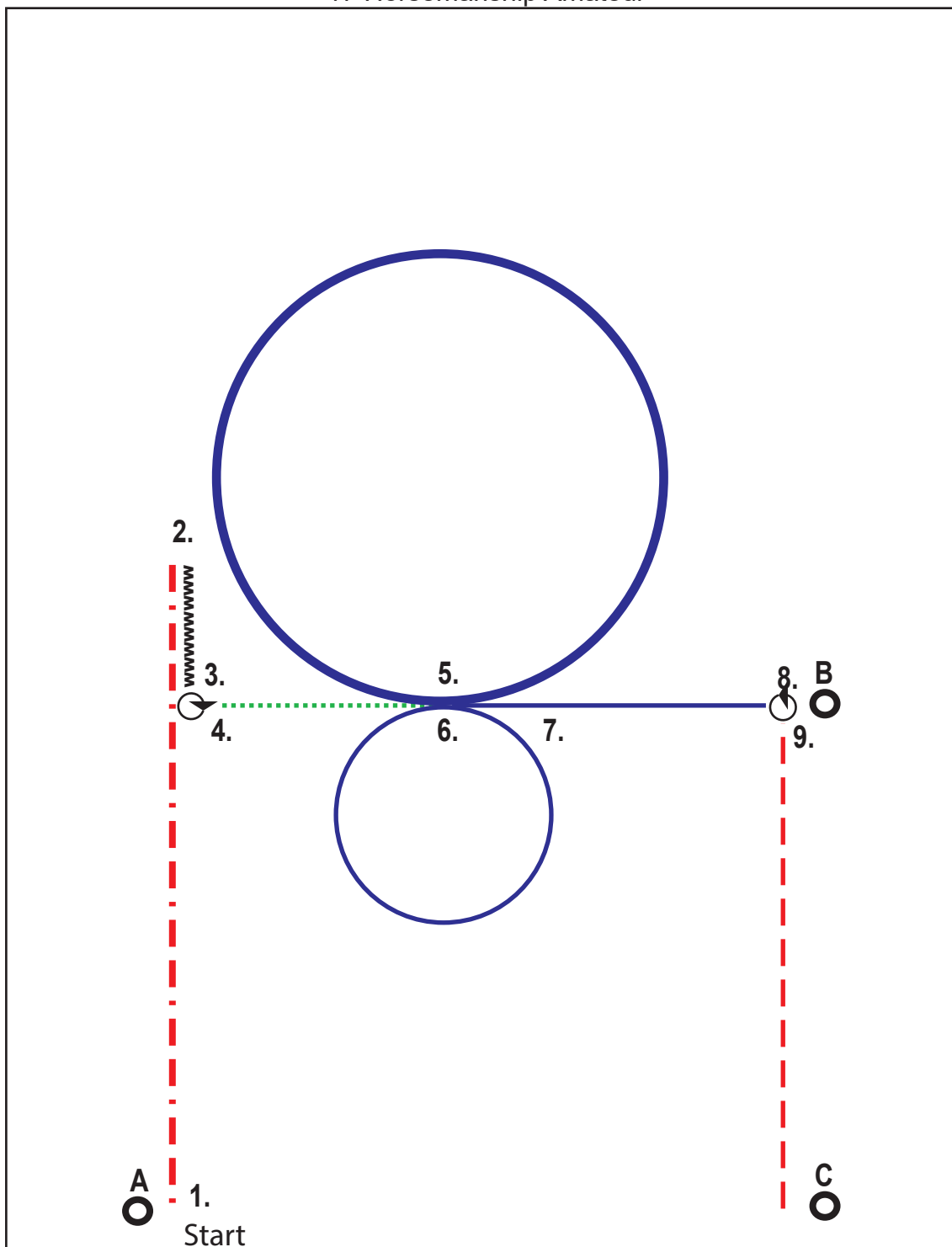

A  
 ○  
 1.  
 Start

8. B  
 ○ ○

C  
 ○

Warmup Arena

Be ready at marker A

- |  |  |
|--|--|
| 1. extended jog                          | 6. change lead, lope a small circle right lead |
| 2. stop, back up at least 1 horse length | 7. continue to lope to B and stop              |
| 3. perform 450° turn right               | 8. perform 270° turn left                      |
| 4. walk halfway to B                     | 9. jog to C, stop                              |
| 5. lope a large, fast circle left lead   | pattern is completed, exit at the walk or jog  |

- |                            |                   |
|----------------------------|-------------------|
| ..... Schritt              | MM backup         |
| - - - - - Trab             | MM → sidepass     |
| - . - . - verstärkter Trab | ○ marker          |
| ———— Galopp                | × Center of Arena |
| ———— verstärkter Galopp    |                   |



designed by Nina Zwölfer

CWN-C ZNS/ARHA WTC Western Star Cup 1  
 Wr. Neustadt/NÖ \* 07.04. - 09.04.2023  
 18 Horsemanship Novice Amateur

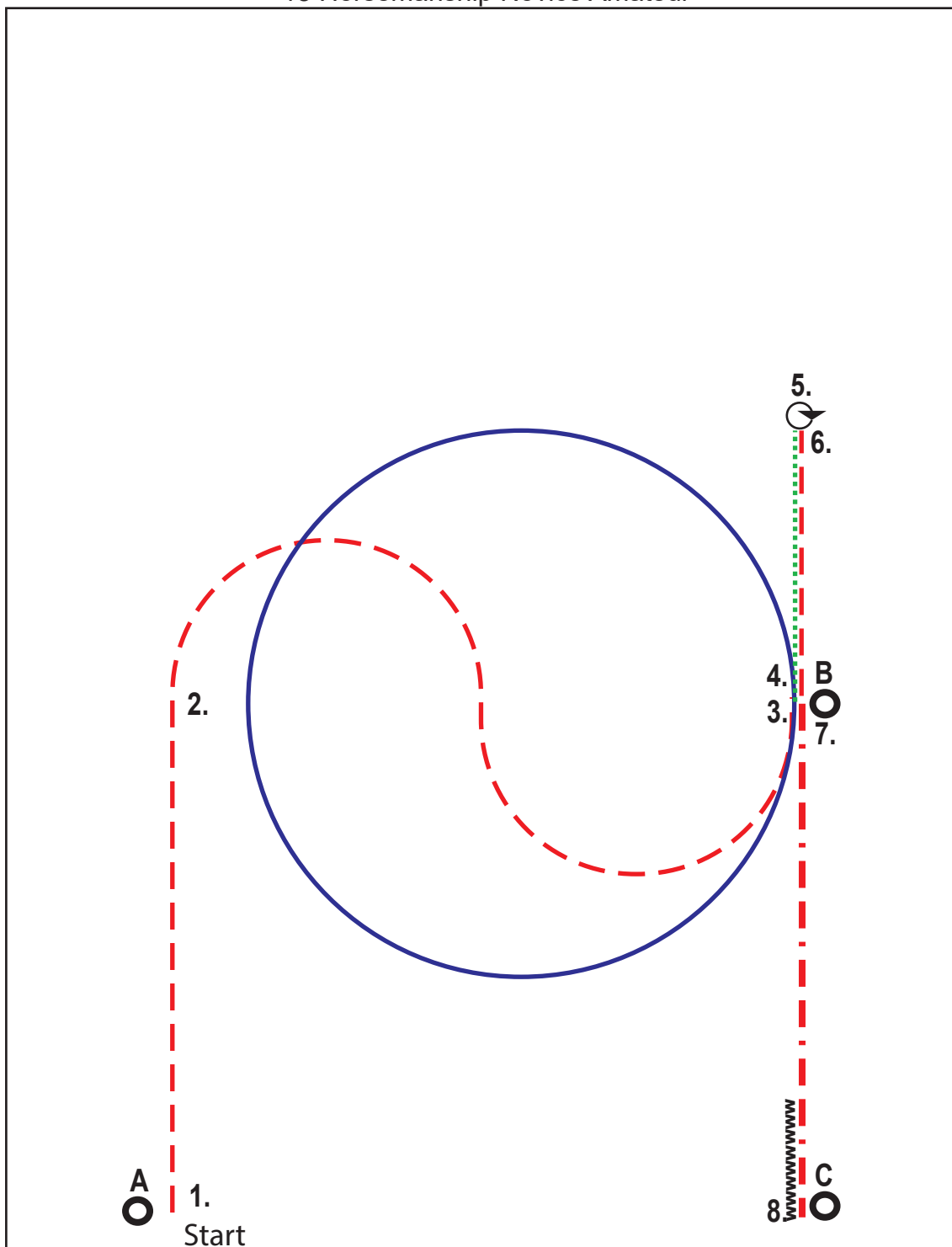

Be ready at marker A

Warmup Arena

1. jog straight line  
 2. perform two half circles to B  
 3. B lope a big circle left lead  
 4. B walk straight line  
 5. stop and perform 540° turn right

6. jog to B  
 7. extended jog to C  
 8. stop, back up at least 1 horse length

pattern is completed, exit at the walk or jog

..... Schritt	MM backup
- - - - - Trab	MM → sidepass
- . - . - verstärkter Trab	○ marker
———— Galopp	⊗ Center of Arena
———— verstärkter Galopp	

  
 JOYFUL TRAINING  
 SUCCESSFUL RIDING  
 designed by Nina Zwölfer

CWN-C ZNS/ARHA WTC Western Star Cup 1  
 Wr. Neustadt/NÖ \* 07.04. - 09.04.2023  
 19 Showmanship at Halter Amateur

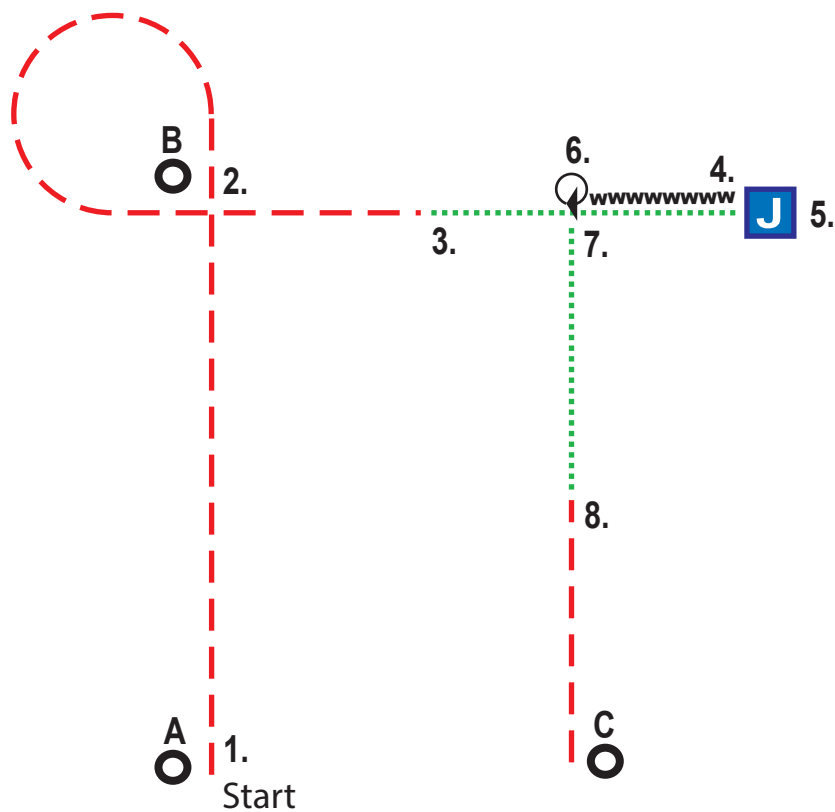

Be ready at marker A

Warmup Arena

- |   |   |
|---|---|
| 1. trot from A to B                           | 5. when dismissed back up 1 horse length      |
| 2. trot circle around B and half way to judge | 6. perform 45° turn right                     |
| 3. walk to Judge and set up for Inspection    | 7. walk half way to C                         |
| 4. Inspection                                 | 8. trot to C, stop                            |
|   | pattern is completed, exit at the walk or jog |

- |                            |                   |
|----------------------------|-------------------|
| ..... Schritt              | MM backup         |
| - - - - - Trab             | MM → sidepass     |
| - . - . - verstärkter Trab | ○ marker          |
| ———— Galopp                | ⊗ Center of Arena |
| ———— verstärkter Galopp    |                   |



designed by Nina Zwölfer

CWN-C ZNS/ARHA WTC Western Star Cup 1  
 Wr. Neustadt/NÖ \* 07.04. - 09.04.2023  
 43 Horsemanship Youth

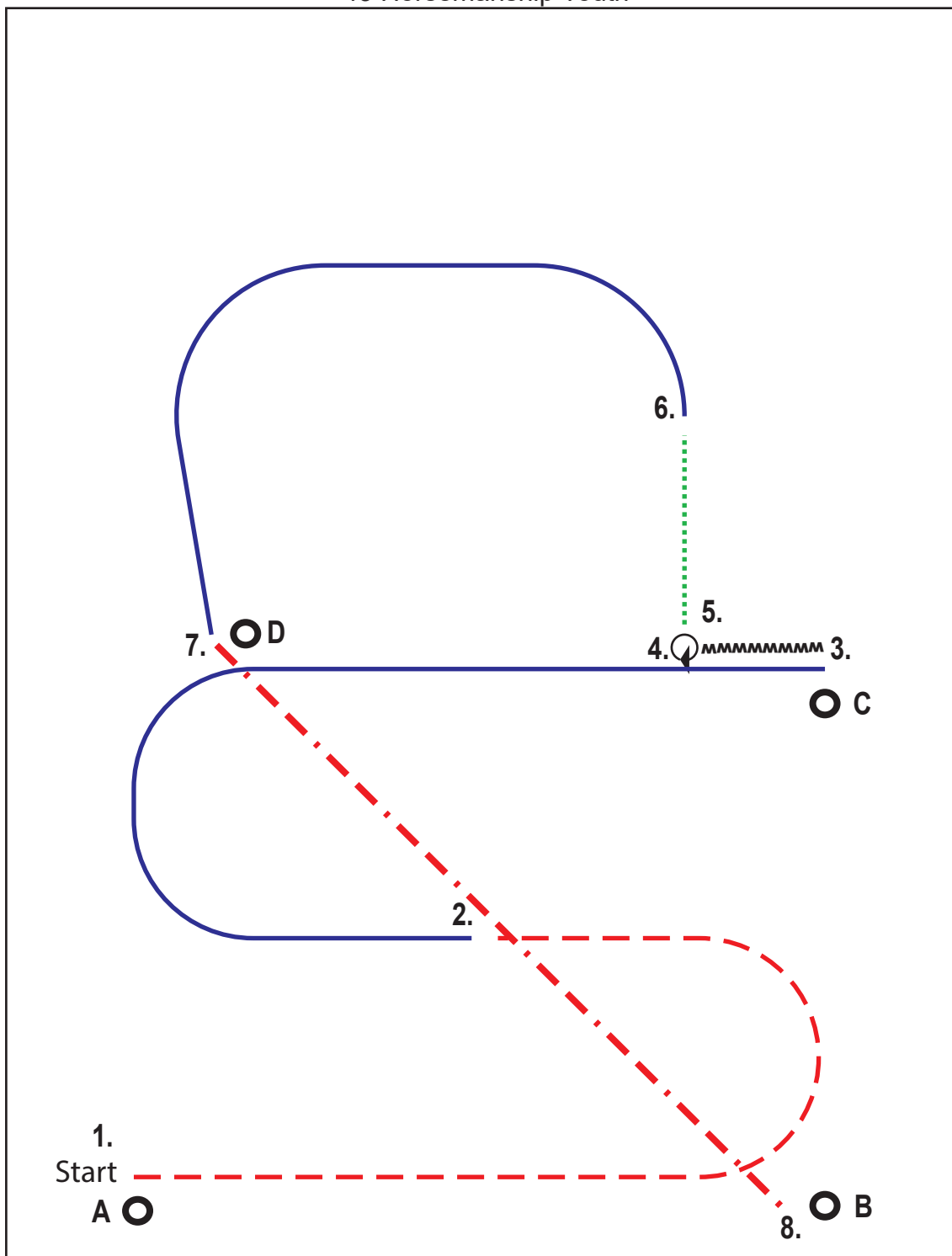

Be ready at marker A Warmup Arena

- |  |   |
|--|---|
| 1. jog half serpentine line                  | 6. lope left lead to D                        |
| 2. lope right lead half serpentine line to C | 7. extended jog to B                          |
| 3. stop, back up at least 1 horse length     | 8. stop                                       |
| 4. perform 270° turn right                   |   |
| 5. walk straight line at least 5m            | pattern is completed, exit at the walk or jog |

- |                          |                  |
|--------------------------|------------------|
| ..... Schritt            | <b>MM</b> backup |
| - - - - Trab             | sidepass         |
| - . - . verstärkter Trab | marker           |
| ———— Galopp              | Center of Arena  |
| ———— verstärkter Galopp  |                  |



designed by Nina Zwölfer

CWN-C ZNS/ARHA WTC Western Star Cup 1  
 Wr. Neustadt/NÖ \* 07.04. - 09.04.2023  
 44 Horsemanship Rookie

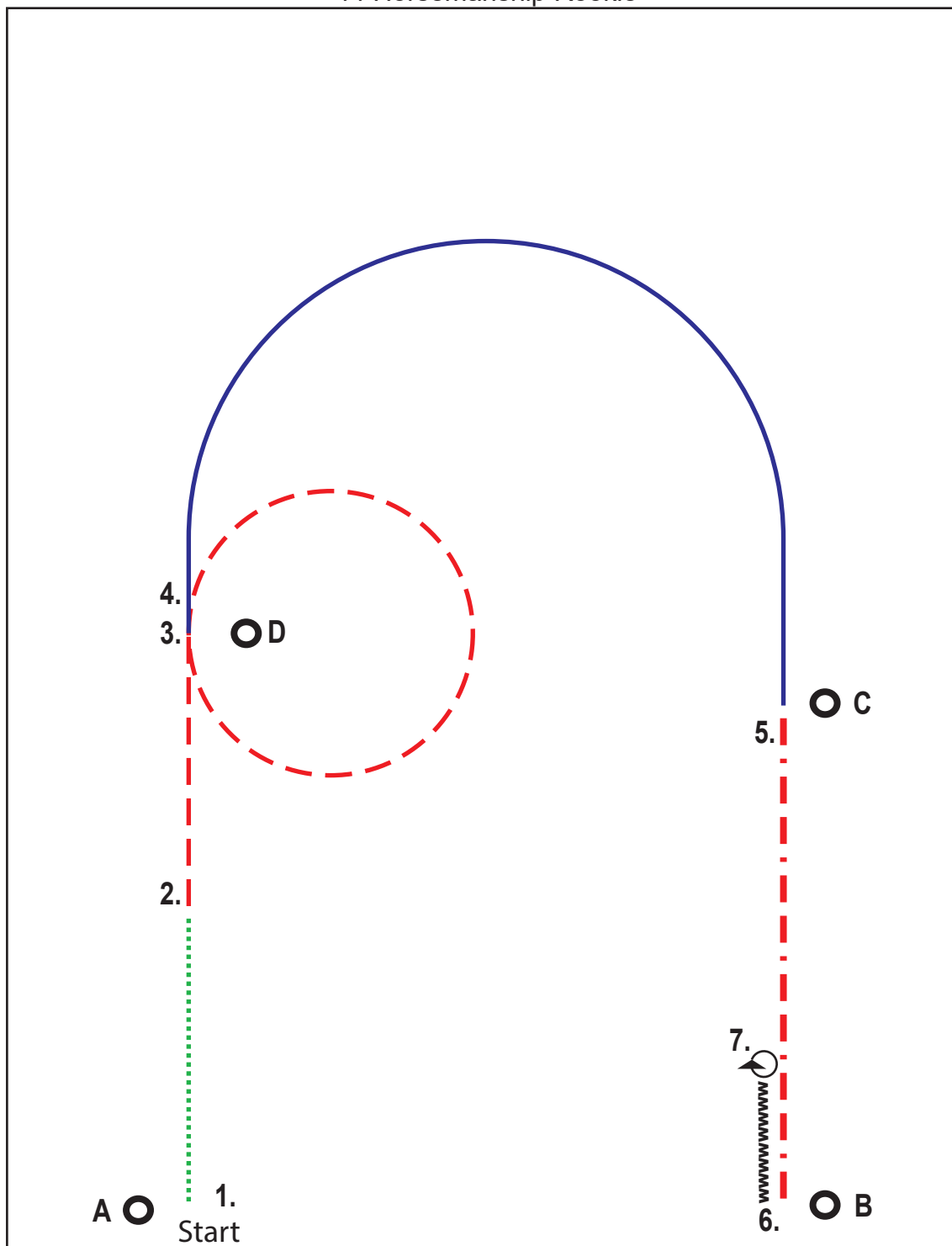

Be ready at marker A

Warmup Arena

1. walk straight line half way to D  
 2. jog to D  
 3. jog small circle  
 4. D lope half circle right lead to C  
 5. extended jog to B

6. stop, back up at least 1 horse length  
 7. perform 360° turn right

pattern is completed, exit at the walk or jog

- ..... Schrittl
- - - - Trabl
- . - . verstärkter Trabl
- Galopp
- verstärkter Galopp
- MM backup
- MM → sidepass
- marker
- × Center of Arena



designed by Nina Zwölfer

CWN-C ZNS/ARHA WTC Western Star Cup 1  
 Wr. Neustadt/NÖ \* 07.04. - 09.04.2023  
 45 Horsemanship Amateur

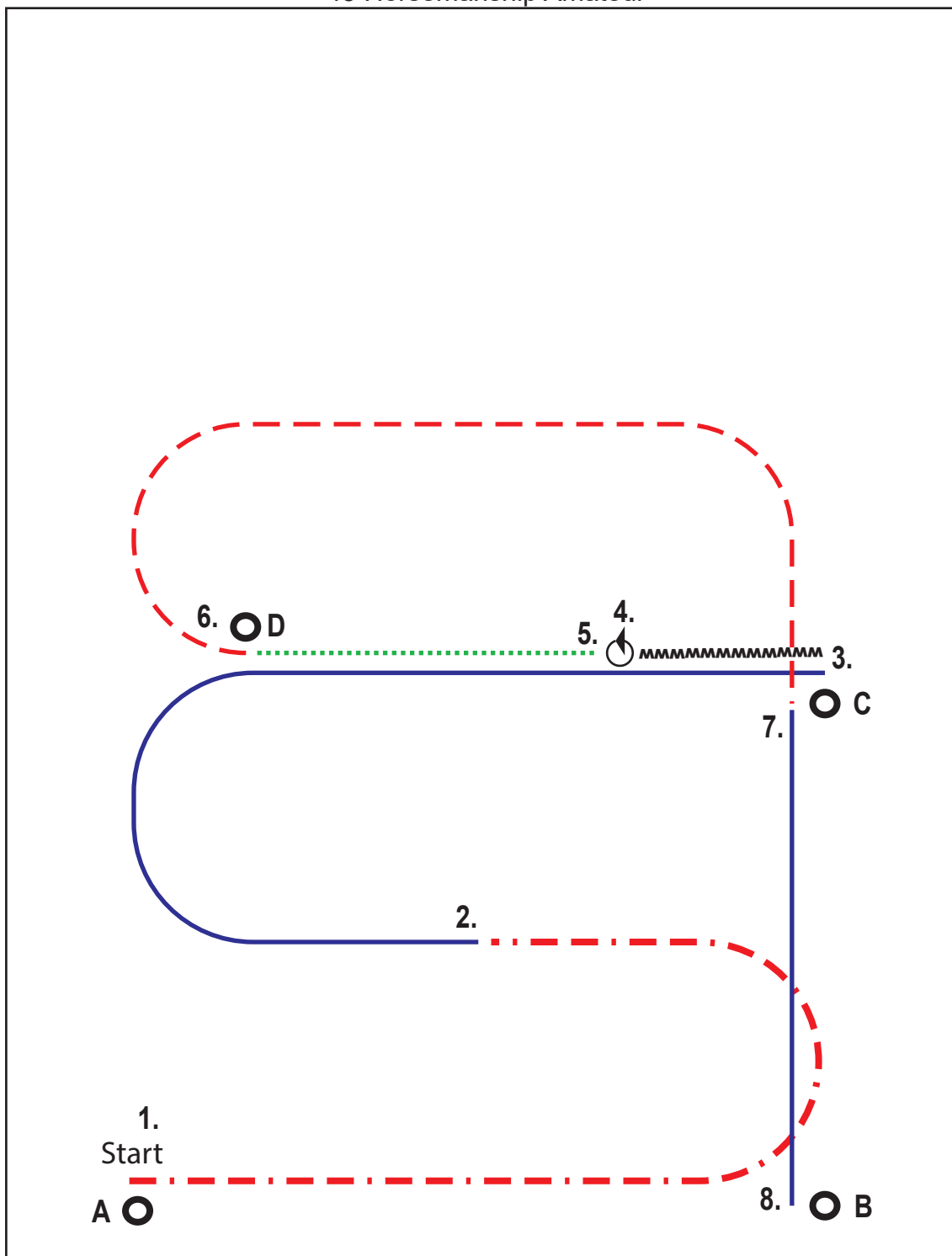

Be ready at marker A

Warmup Arena

- |  |   |
|--|---|
| 1. extended jog half serpentine line         | 6. jog to C                                   |
| 2. lope right lead half serpentine line to C | 7. lope left lead to B                        |
| 3. stop, back up at least 2 horse length     | 8. stop                                       |
| 4. perform 540° turn left                    |   |
| 5. walk straight line to D                   | pattern is completed, exit at the walk or jog |

- |                            |                   |
|----------------------------|-------------------|
| ..... Schritt              | MM backup         |
| - - - - - Trab             | MM → sidepass     |
| - . - . - verstärkter Trab | ○ marker          |
| ———— Galopp                | ⊗ Center of Arena |
| ———— verstärkter Galopp    |                   |



designed by Nina Zwölfer

CWN-C ZNS/ARHA WTC Western Star Cup 1  
 Wr. Neustadt/NÖ \* 07.04. - 09.04.2023  
 81 Horsemanship Youth

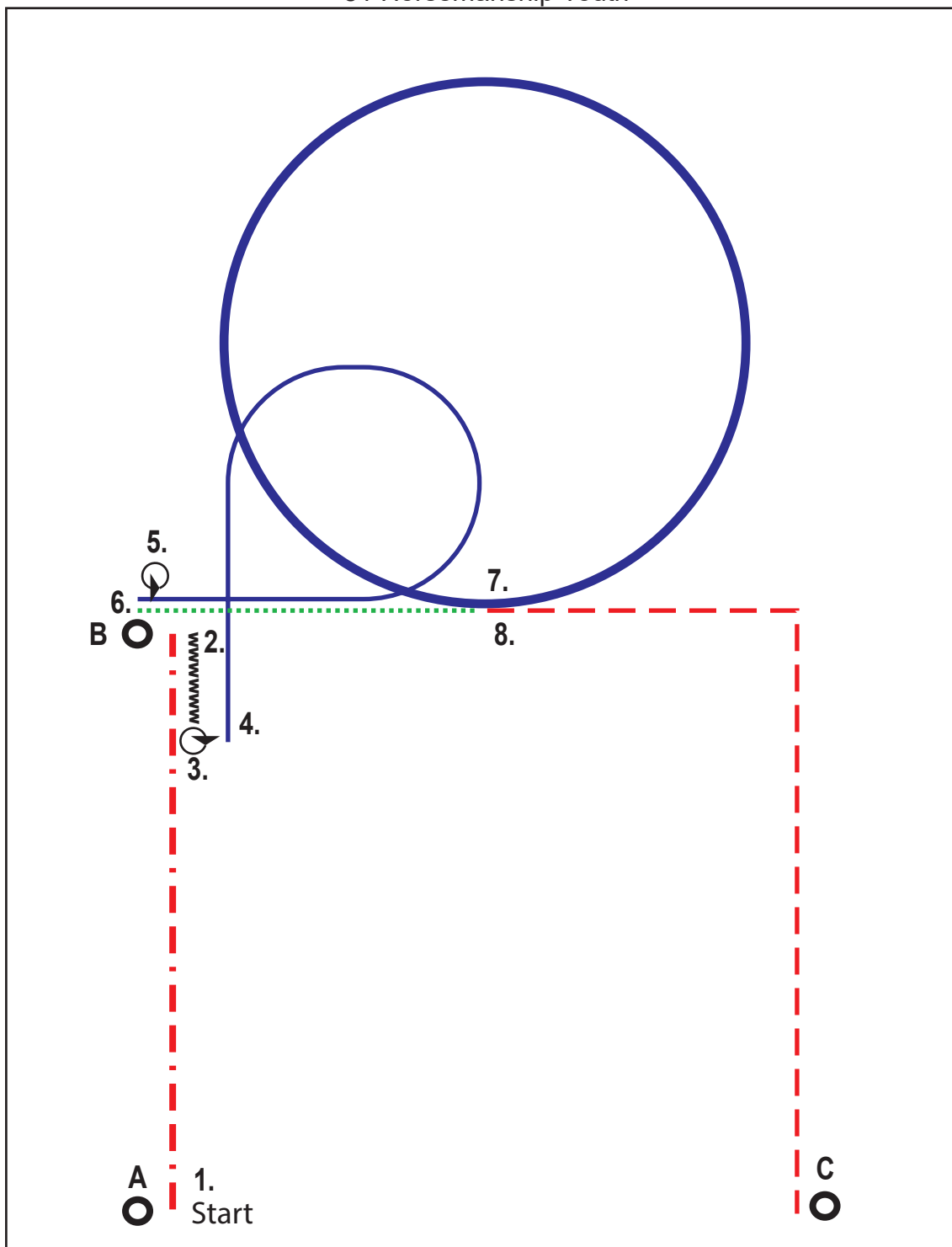

A ○ 1. Start

C ○

Warmup Arena

Be ready at marker A

- |  |   |
|--|---|
| 1. extended jog to B                           | 6. walk straight line                         |
| 2. B stop, back up at least 1 horse length     | 7. lope a large, fast circle left lead        |
| 3. perform 360° turn right                     | 8. jog square corner to C                     |
| 4. lope to B and perform 3/4 circle right lead |   |
| 5. B stop, perform 180° turn left              | pattern is completed, exit at the walk or jog |

- |                            |                   |
|----------------------------|-------------------|
| ..... Schritt              | MM backup         |
| - - - - - Trab             | MM → sidepass     |
| - . - . - verstärkter Trab | ○ marker          |
| — Galopp                   | ⊗ Center of Arena |
| — verstärkter Galopp       |                   |



designed by Nina Zwölfer



CWN-C ZNS/ARHA WTC Western Star Cup 1  
 Wr. Neustadt/NÖ \* 07.04. - 09.04.2023  
 82 Horsemanship Rookie

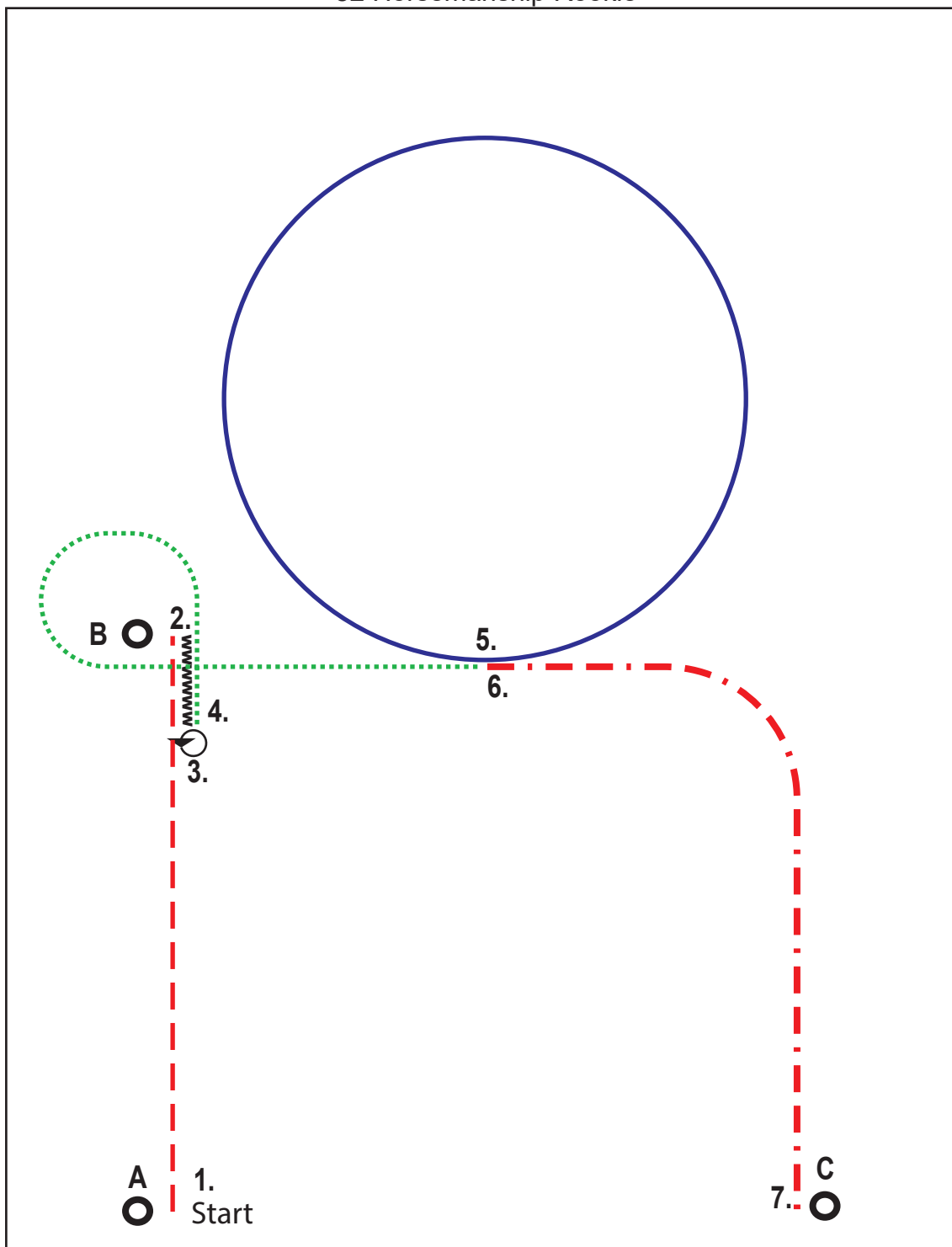

Be ready at marker A Warmup Arena

1. jog to B	6. extended jog to C
2. B stop, back up at least 1 horse length	7. stop
3. perform 360° turn left	
4. walk to B, 3/4 circle, straight line	
5. lope a large circle left lead	pattern is completed, exit at the walk or jog

<ul style="list-style-type: none"> <li><span style="color: green;">.....</span> Schritt</li> <li><span style="color: red;">- - -</span> Trab</li> <li><span style="color: red;">- . - .</span> verstärkter Trab</li> <li><span style="color: blue;">—————</span> Galopp</li> <li><span style="color: blue;">—————</span> verstärkter Galopp</li> </ul>	<ul style="list-style-type: none"> <li><b>MM</b> backup</li> <li> sidepass</li> <li> marker</li> <li> Center of Arena</li> </ul>
--	--

designed by Nina Zwölfer

CWN-C ZNS/ARHA WTC Western Star Cup 1  
 Wr. Neustadt/NÖ \* 07.04. - 09.04.2023  
 83 Horsemanship Youngster

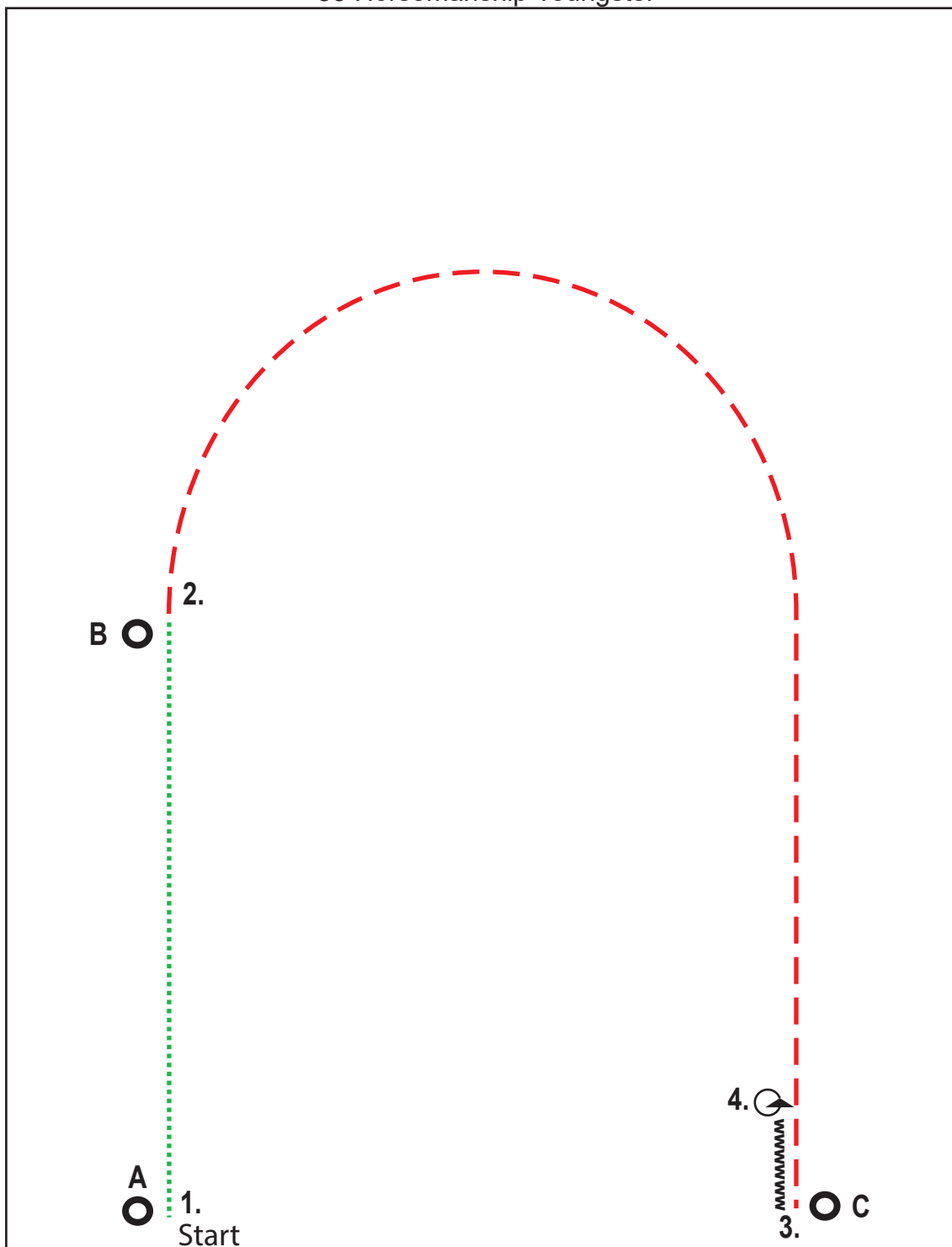

Be ready at marker C Warmup Arena

1. walk to B
2. jog big 1/2 circle and straight line to C
3. back up at least 1 horse length
4. perform 360° turn left

pattern is completed, exit at the walk or jog

- |                          |                   |
|--------------------------|-------------------|
| ..... Schritt            | MM backup         |
| - - - - Trab             | MM → sidepass     |
| - . - . verstärkter Trab | ○ marker          |
| — Galopp                 | × Center of Arena |
| — verstärkter Galopp     |                   |



designed by Nina Zwölfer

CWN-C ZNS/ARHA WTC Western Star Cup 1  
 Wr. Neustadt/NÖ \* 07.04. - 09.04.2023  
 84 Horsemanship Novice Amateur

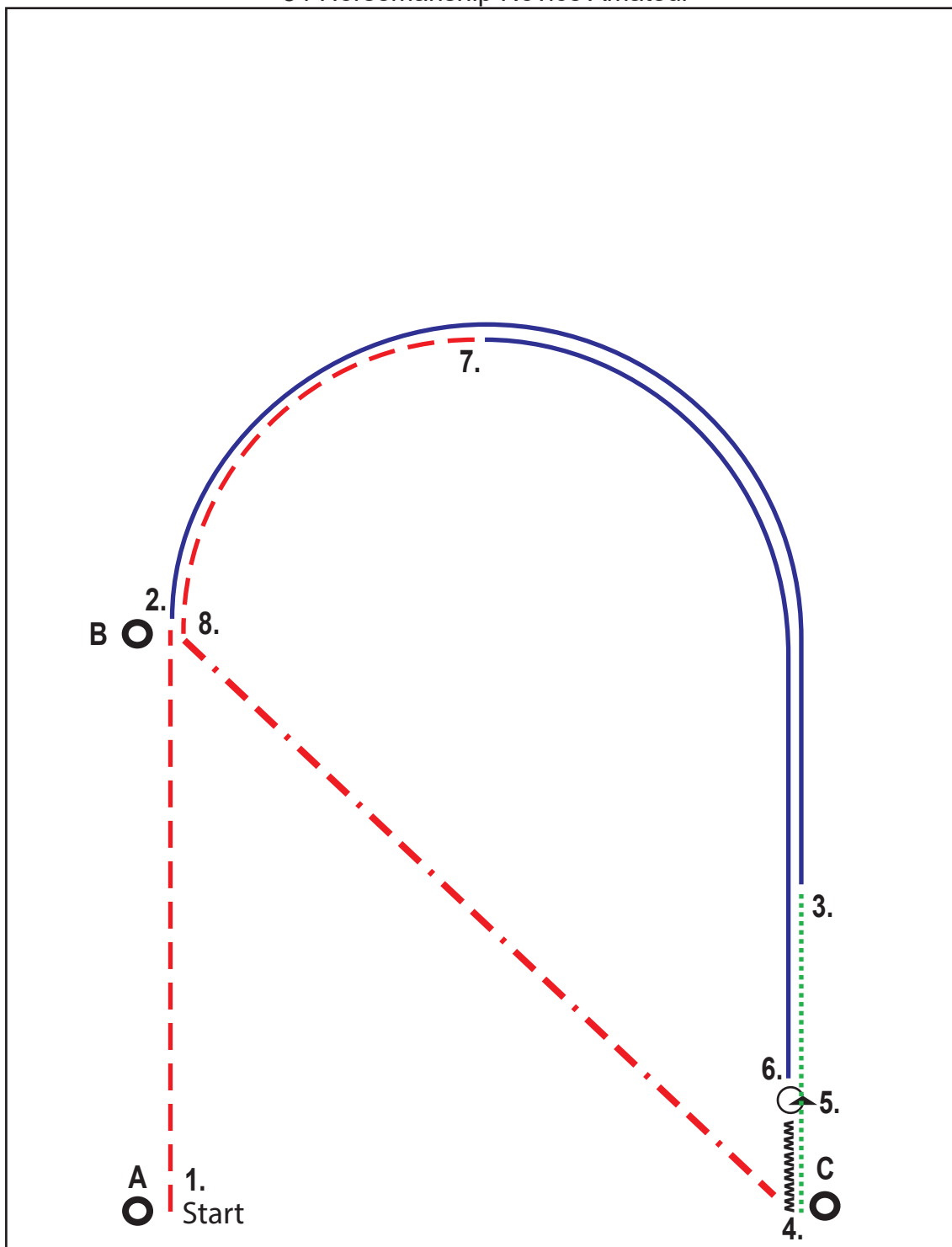

Be ready at marker A

Warmup Arena

1. jog to B	6. lope straight and 1/4 circle left lead
2. lope half circle right lead, straight halfway to C	7. jog 1/4 circle to B
3. walk to C	8. extended jog to C, stop
4. back up at least 1 horse length	
5. perform 540° turn left	pattern is completed, exit at the walk or jog

- ..... Schrittl
- - - - Trab
- . - . verstärkter Trab
- Galopp
- verstärkter Galopp
- MM backup
- MM → sidepass
- marker
- ⊗ Center of Arena



designed by Nina Zwölfer

CWN-C ZNS/ARHA WTC Western Star Cup 1  
 Wr. Neustadt/NÖ \* 07.04. - 09.04.2023  
 85 Horsemanship Open

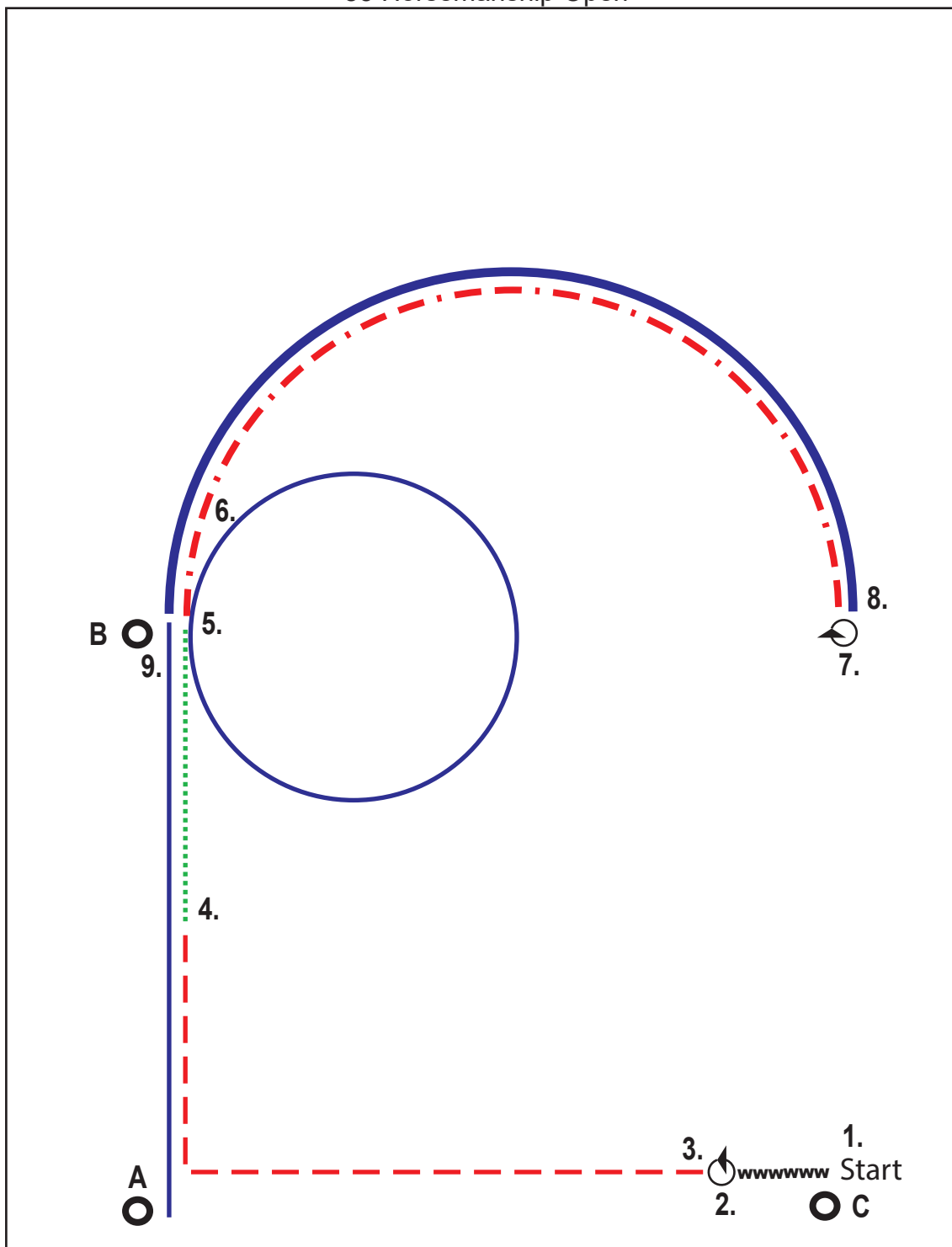

Be ready at marker C Warmup Arena

- |                                    |   |
|------------------------------------|---|
| 1. back up at least 1 horse length | 6. extended jog big 1/2 circle                |
| 2. perform 540° turn left          | 7. stop, perform 540° turn right              |
| 3. jog square corner halfway to B  | 8. extended lope left lead to B               |
| 4. walk to B                       | 9. regular lope left lead to A, stop          |
| 5. lope small circle right lead    | pattern is completed, exit at the walk or jog |

- |                          |                      |
|--------------------------|----------------------|
| ..... Schrittl           | <b>MM</b> backup     |
| - - - - Trab             | <b>nn</b> → sidepass |
| - . - . verstärkter Trab | ⊙ marker             |
| ———— Galopp              | ⊗ Center of Arena    |
| ———— verstärkter Galopp  |                      |



designed by Nina Zwölfer