

CWN-C ZNS / Österreichische Meisterschaften
 Wr. Neustadt/NÖ * 27.05. - 29.05.2023
 001 Trail Rookie

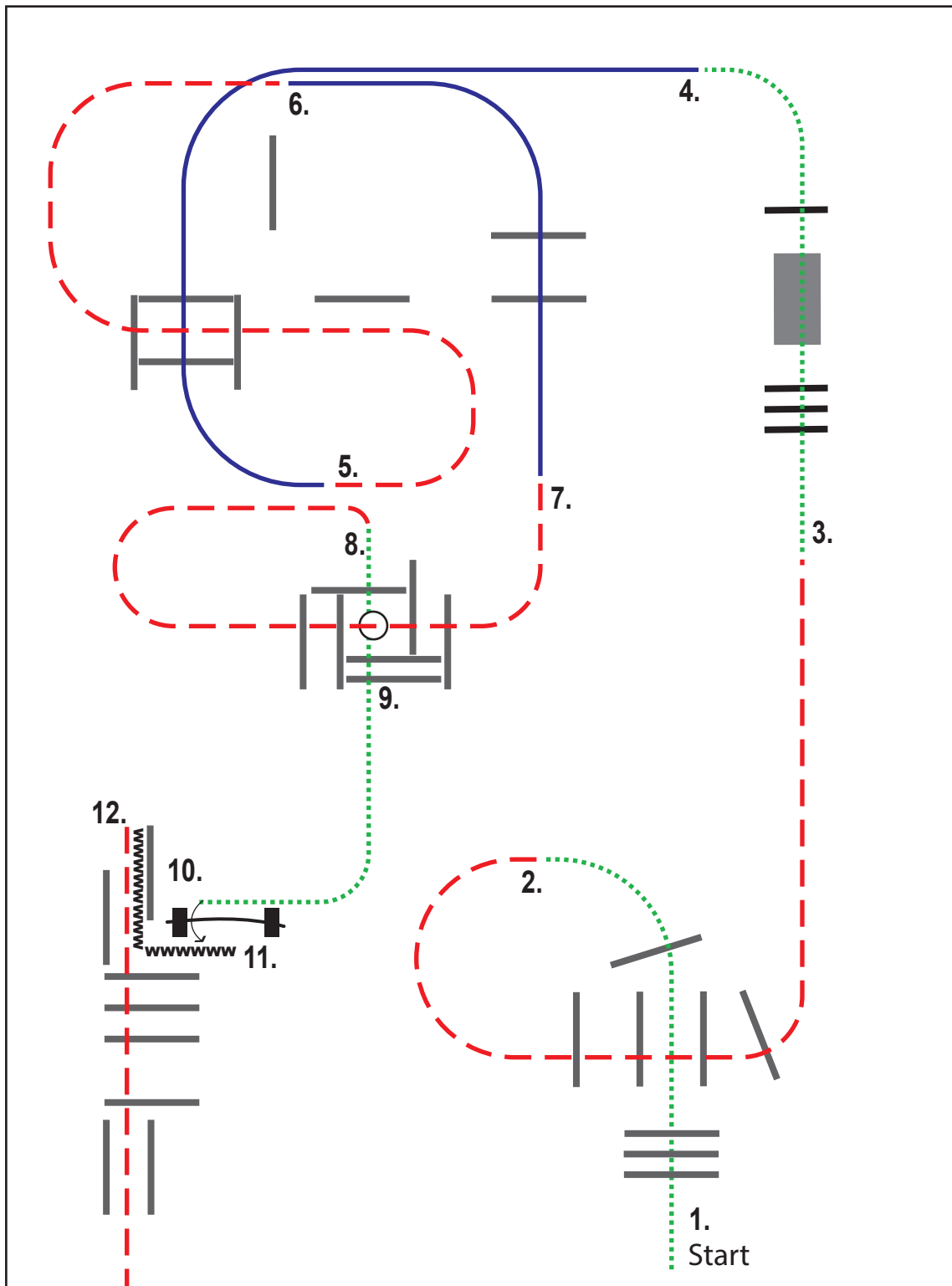

- | | |
|-------------------------------|--|
| 1. walk over poles | 7. jog over poles |
| 2. jog over poles | 8. walk into box, turn 360° either way |
| 3. walk over poles and bridge | 9. walk over poles to gate |
| 4. lope over poles left lead | 10. gate left hand |
| 5. jog over poles | 11. back up „L“ |
| 6. lope over poles right lead | 12. jog over poles |

- | | |
|----------------|--------------|
| Schritt | ↗ Seitwärts |
| - - - - - Trab | ○ Pylonen |
| ———— Galopp | X Erhöhungen |
| MMM Rückwärts | ⊢ Tor |



designed by Nina Zwölfer

Pattern Trail - Set 6 - #1 - LK 1/2 sen.

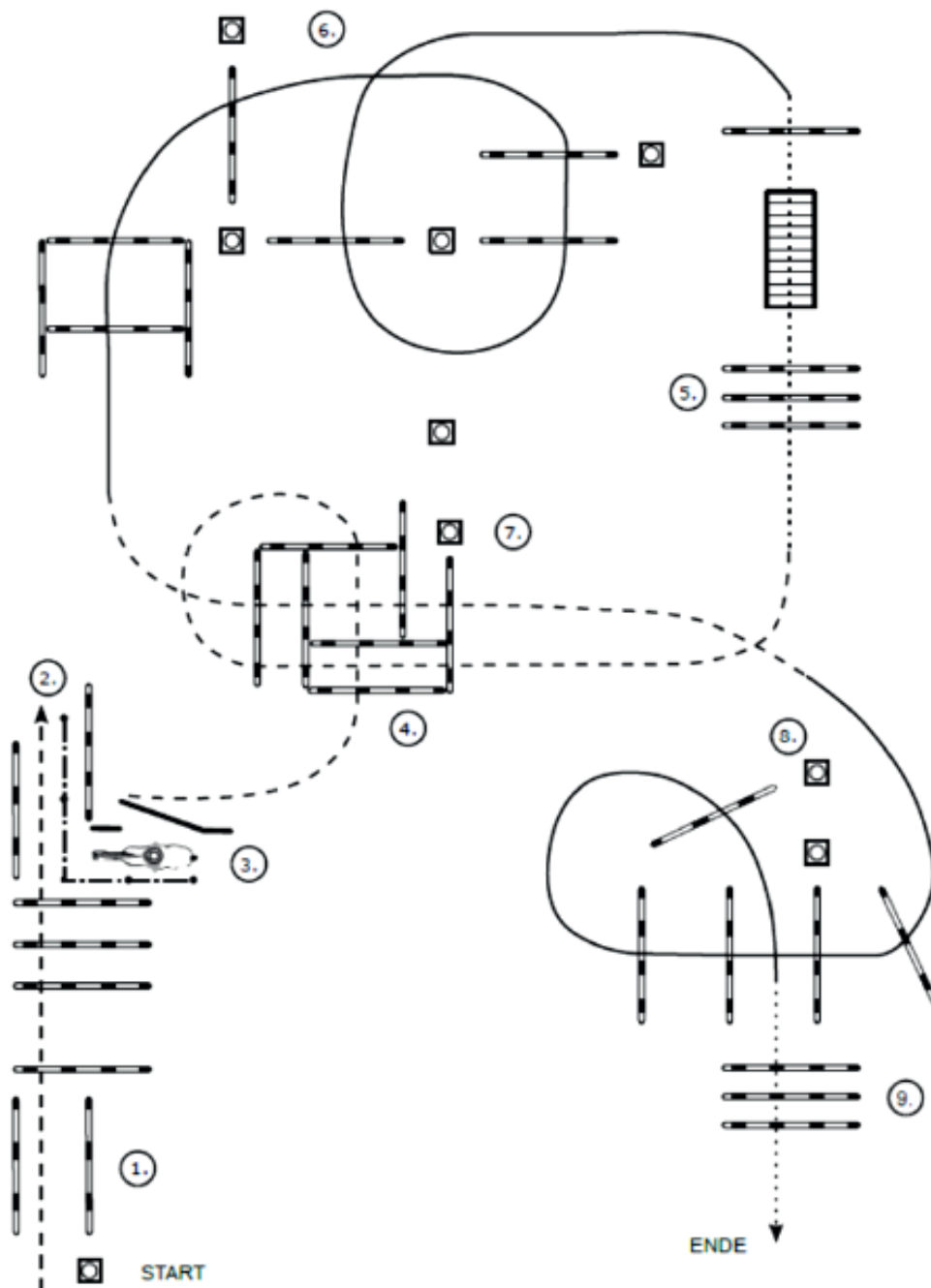

- (1) Jog over, Stop
- (2) Back up
- (3) Tor (rechte Hand), Jog out
- (4) Jog over
- (5) Stop/Übergang zum Walk, Walk over, Brücke, Walk over
- (6) Lope over (Linksgalopp)
- (7) Jog over
- (8) Lope over (Rechtsgalopp)
- (9) Lope in, Stop/Übergang zum Walk, Walk over

CWN-C ZNS / Österreichische Meisterschaften
 Wr. Neustadt/NÖ * 27.05. - 29.05.2023
 003 Trail Junior Open

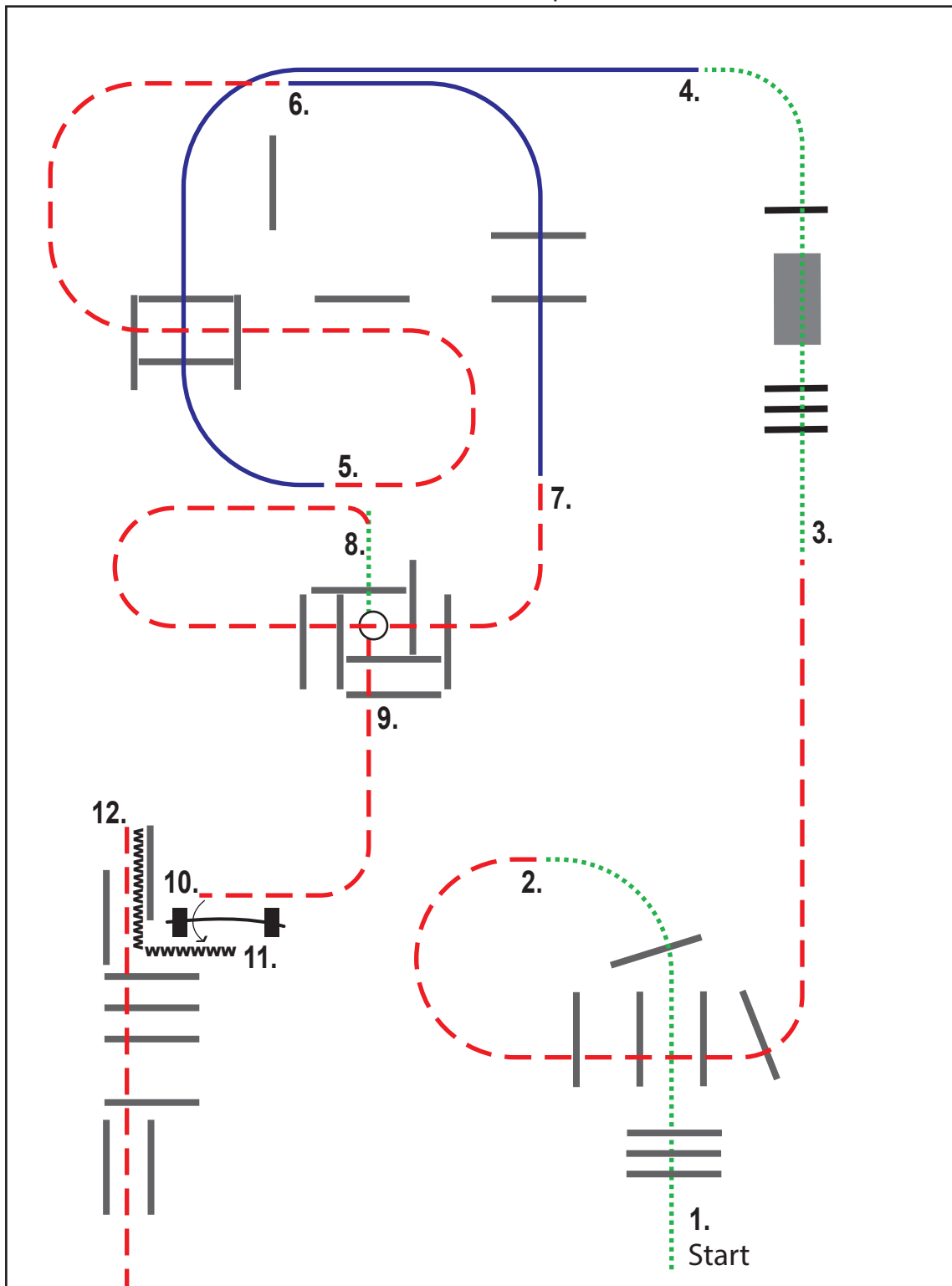

- | | |
|-------------------------------|--|
| 1. walk over poles | 7. jog over poles |
| 2. jog over poles | 8. walk into box, turn 360° either way |
| 3. walk over poles and bridge | 9. jog over poles to gate |
| 4. lope over poles left lead | 10. gate left hand |
| 5. jog over poles | 11. back up „L“ |
| 6. lope over poles right lead | 12. jog over poles |

- | | |
|----------------|--------------|
| Schrittl | ↔ Seitwärts |
| - - - - Trab | ○ Pylonen |
| ———— Galopp | X Erhöhungen |
| MMM Rückwärts | ⊢ Tor |



designed by Nina Zwölfer

CWN-C ZNS / Österreichische Meisterschaften
 Wr. Neustadt/NÖ * 27.05. - 29.05.2023
 004 Trail Amateur

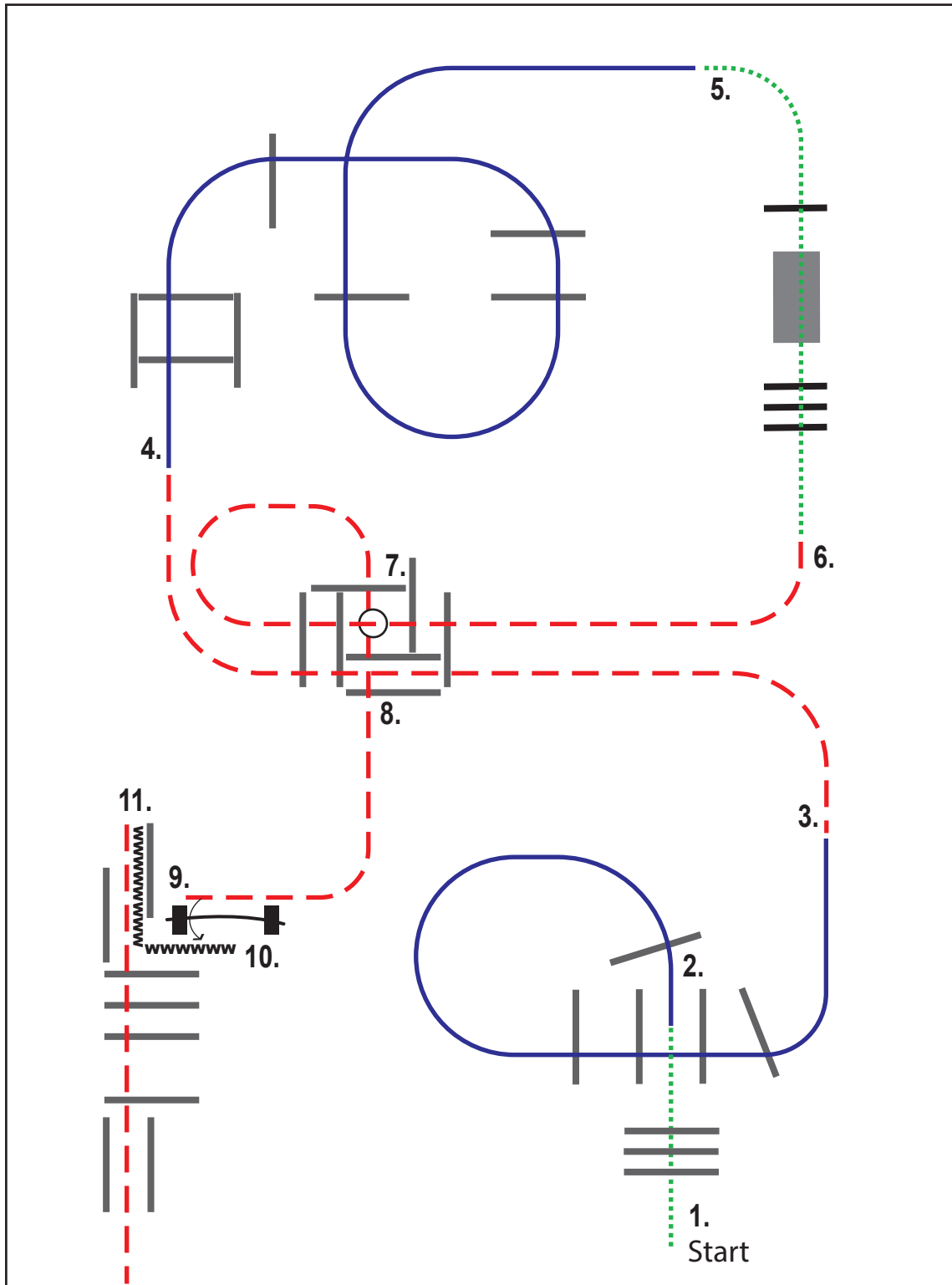

- 1. walk over poles
- 2. lope over poles left lead
- 3. jog over poles
- 4. lope over poles right lead
- 5. walk over poles and bridge
- 6. jog over poles into box

- 7. turn 720° either way
- 8. jog out, over poles to gate
- 9. gate left hand
- 10. back up „L“
- 11. jog over poles

..... Schritt

- - - - - Trab

———— Galopp

MMM Rückwärts

↔ Seitwärts

○ Pylonen

X Erhöhungen

⊥ Tor



designed by Nina Zwölfer

CWN-C ZNS / Österreichische Meisterschaften
 Wr. Neustadt/NÖ * 27.05. - 29.05.2023
 005 Trail Senior Open

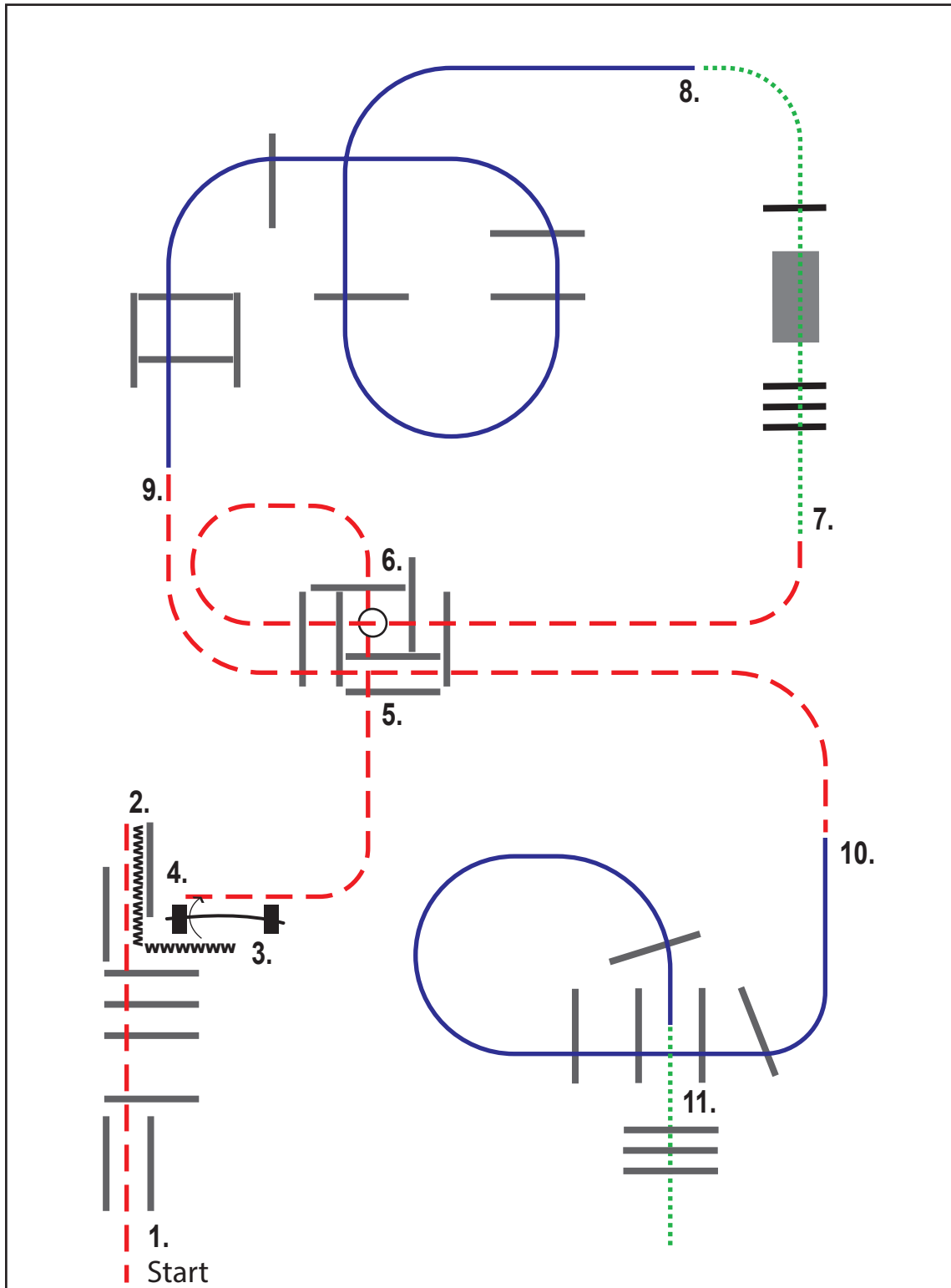

- 1. jog over poles
- 2. back up „L“
- 3. gate right hand
- 4. jog over poles into box
- 5. turn 720° either way
- 6. jog out and over poles

- 7. walk over poles and bridge
- 8. lope over poles left lead
- 9. jog over poles
- 10. lope over poles right lead
- 11. walk over poles

- Schritt
- - - - - Trab
- Galopp
- MMM Rückwärts

- ↔ Seitwärts
- Pylonen
- X Erhöhungen
- H Tor



designed by Nina Zwölfer

Pattern Trail - Set 6 - #4 - QLK 1/2 jun.

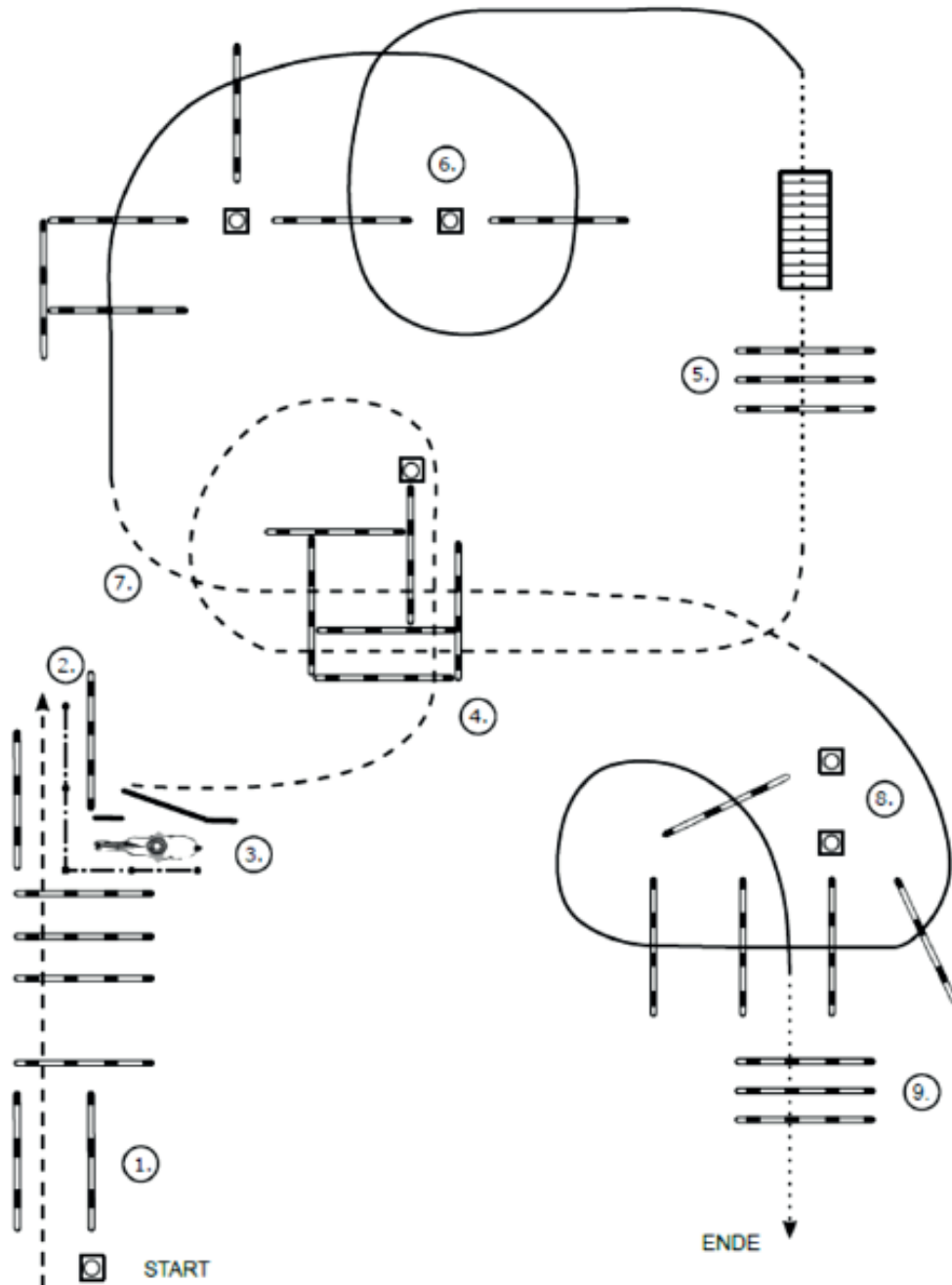

- (1) Jog over, Stop
- (2) Back up
- (3) Tor (rechte Hand), Jog out
- (4) Jog over
- (5) Stop/Übergang zum Walk, Walk over, Brücke
- (6) Lope over (Linksgalopp)
- (7) Jog over
- (8) Lope over (Rechtsgalopp)
- (9) Lope in, Stop/Übergang zum Walk, Walk over

Pattern Trail - Set ϕ - #2 - QLK 1/2 sen.

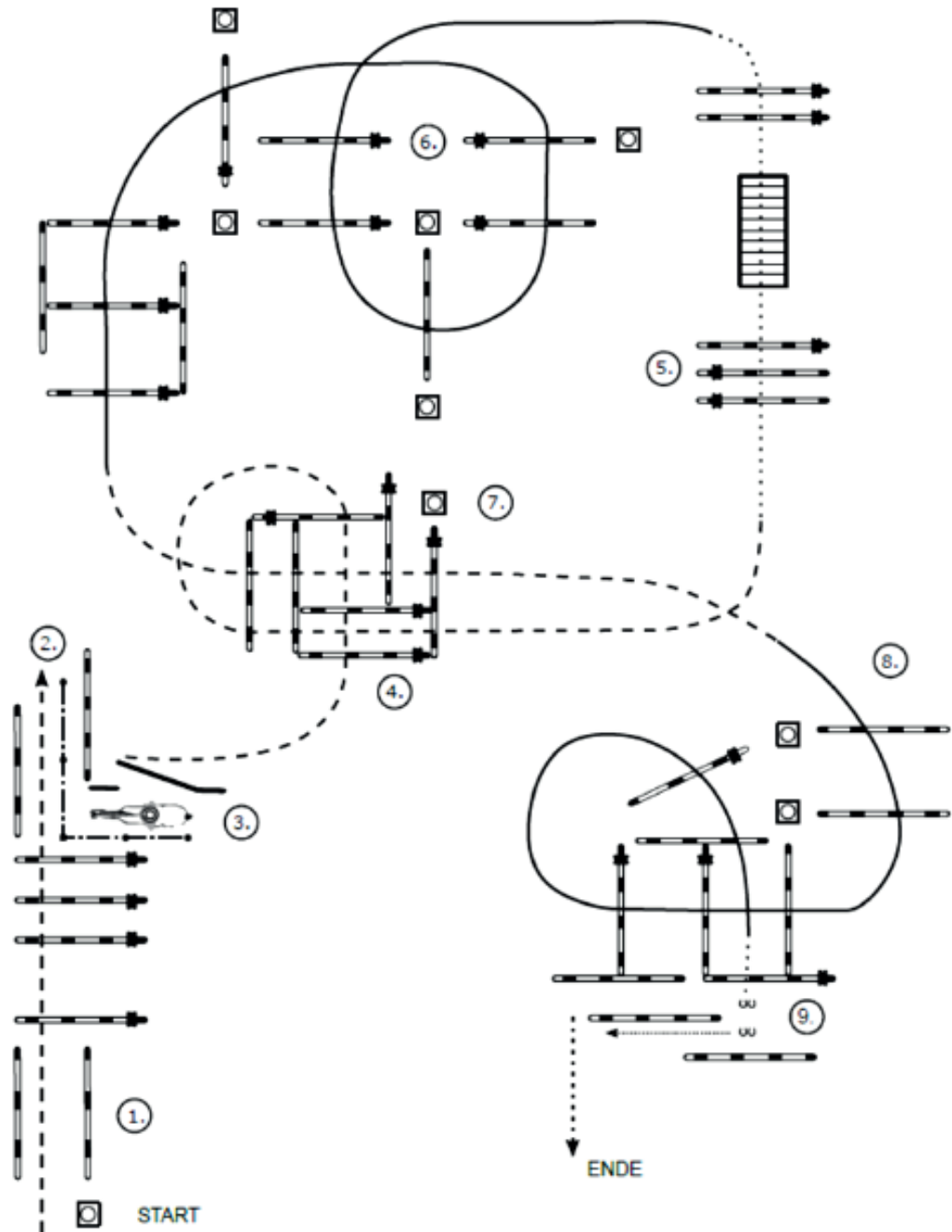

- (1) Jog over, Stop
- (2) Back up
- (3) Tor (rechte Hand), Jog out
- (4) Jog over
- (5) Stop/Übergang zum Walk, Walk over, Brücke, Walk over
- (6) Lope over (Linksgalopp)
- (7) Jog over
- (8) Lope over (Rechtsgalopp)
- (9) Lope in, Stop/Übergang zum Walk, Walk over, Seidepass 2. Stange

CWN-C ZNS / Österreichische Meisterschaften
 Wr. Neustadt/NÖ * 27.05. - 29.05.2023
 008 Trail Novice Amateur

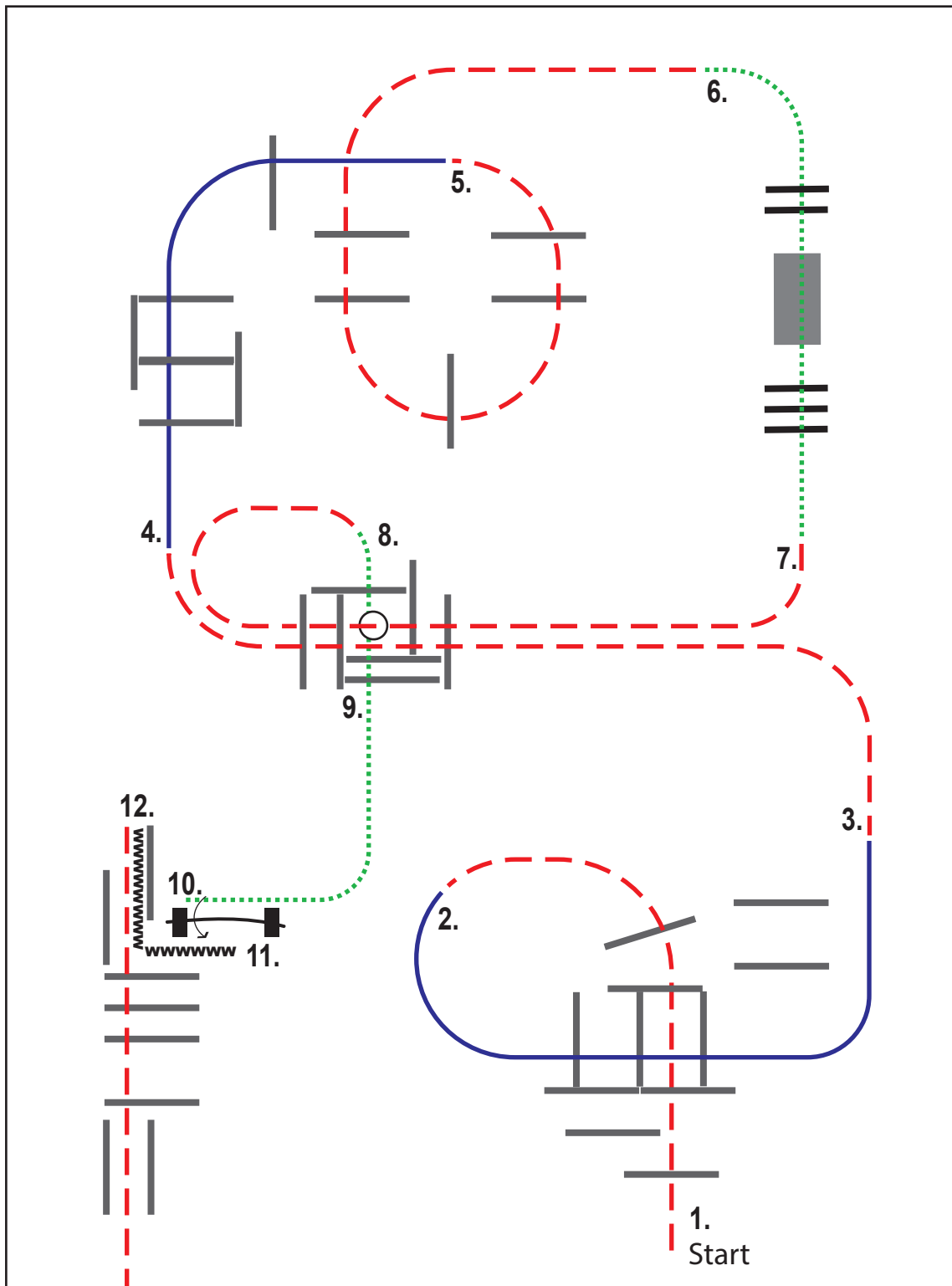

- 1. jog over poles
- 2. lope over poles left lead
- 3. jog over poles
- 4. lope over poles right lead
- 5. jog over poles
- 6. walk over poles and bridge

- 7. jog over poles
- 8. walk into box, turn 360° either way
- 9. walk over poles to gate
- 10. gate left hand
- 11. back up „L“
- 12. jog over poles

..... Schritt

- - - - - Trab

———— Galopp

MMM Rückwärts

↗ Seitwärts

○ Pylonen

X Erhöhungen

⊥ Tor



designed by Nina Zwölfer

CWN-C ZNS / Österreichische Meisterschaften
 Wr. Neustadt/NÖ * 27.05. - 29.05.2023
 038 Trail Open Prime Time

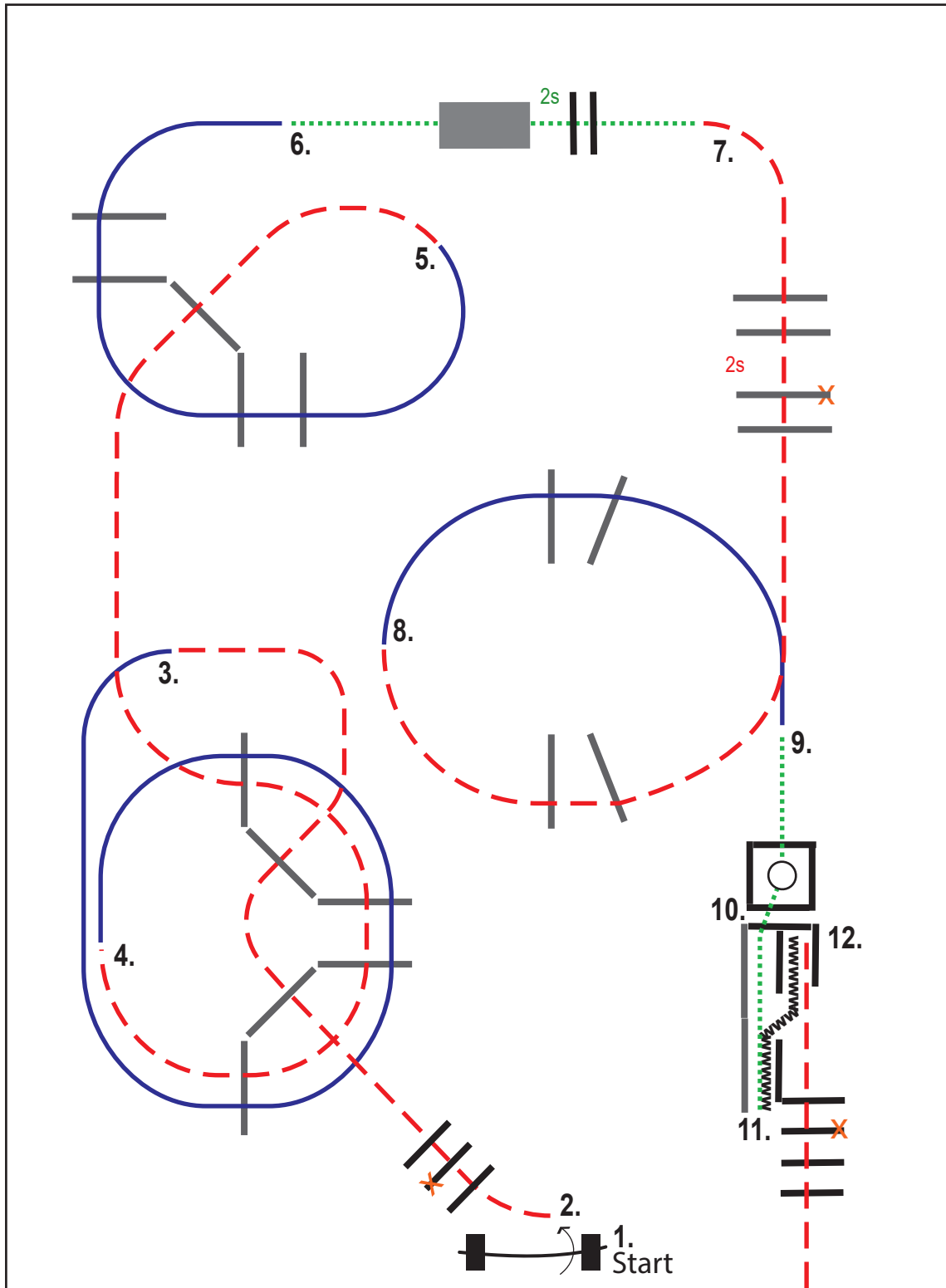

- | | |
|-------------------------------|---|
| 1. gate left hand | 7. jog over poles |
| 2. jog over poles | 8. lope over poles right lead |
| 3. lope over poles left lead | 9. walk over into the box, turn 360° either way |
| 4. jog over poles | 10. walk over poles into chute |
| 5. lope over poles right lead | 11. back up |
| 6. walk over poles and bridge | 12. jog over poles |

- | | |
|---------------|--------------|
| Schritt | ↔ Seitwärts |
| - - - - Trab | ○ Pylonen |
| — Galopp | X Erhöhungen |
| MMM Rückwärts | ⊥ Tor |



designed by Nina Zwölfer

CWN-C ZNS / Österreichische Meisterschaften
 Wr. Neustadt/NÖ * 27.05. - 29.05.2023
 039 Trail Rookie

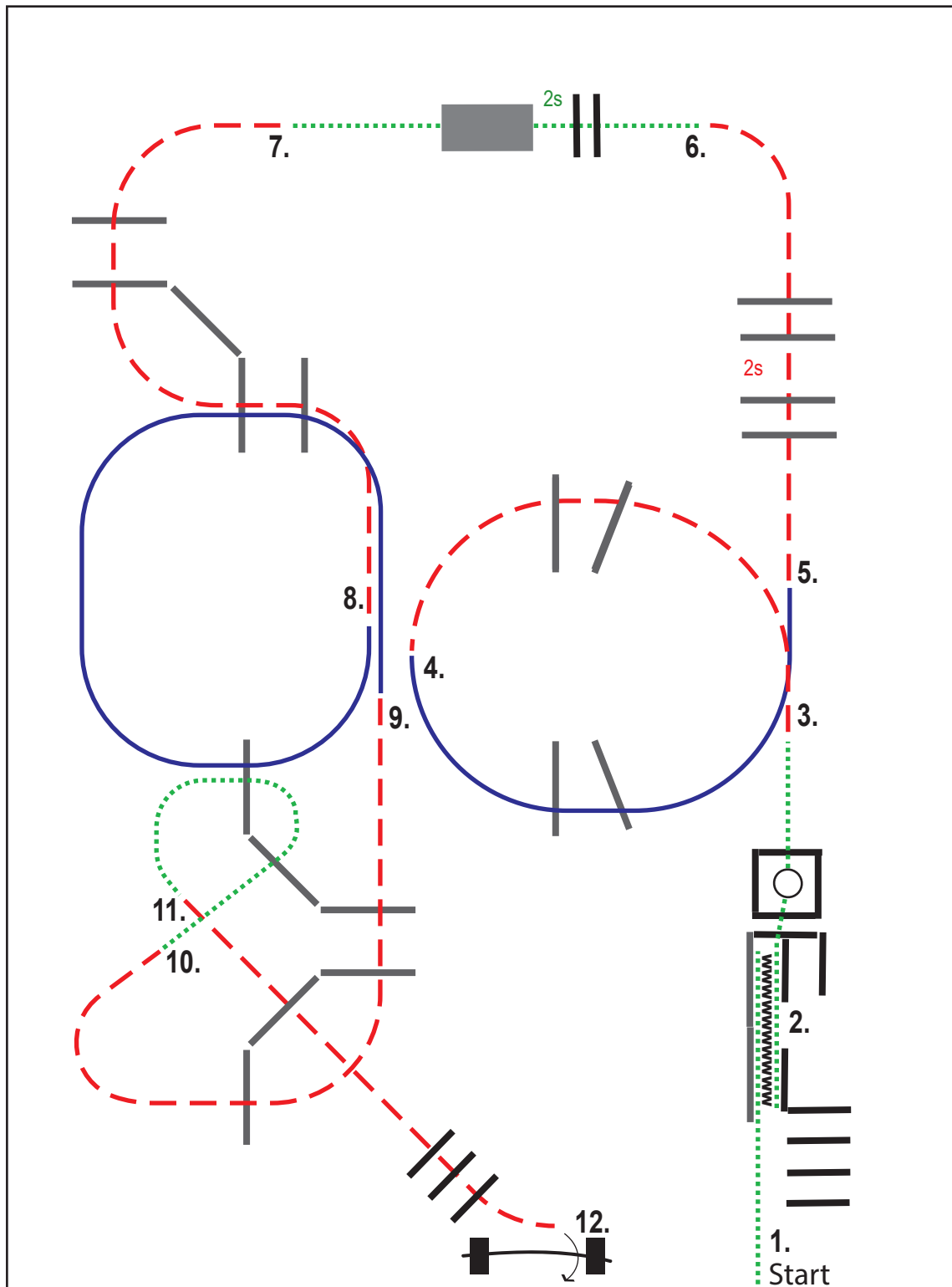

- | | |
|---|--------------------------------|
| 1. walk into chute and backup | 7. jog over poles |
| 2. walk over into the box, turn 360° either way | 8. lope over poles right lead |
| 3. jog over poles | 9. jog over poles |
| 4. lope over poles left lead | 10. walk over poles |
| 5. jog over poles | 11. jog over poles to the gate |
| 6. walk over poles and bridge | 12. gate right hand |

- | | |
|----------------|--------------|
| Schrittl | ↔ Seitwärts |
| - - - Trab | ○ Pylonen |
| — Galopp | X Erhöhungen |
| MMM Rückwärts | ⊥ Tor |



designed by Nina Zwölfer

CWN-C ZNS / Österreichische Meisterschaften
 Wr. Neustadt/NÖ * 27.05. - 29.05.2023
 040 Trail Youth

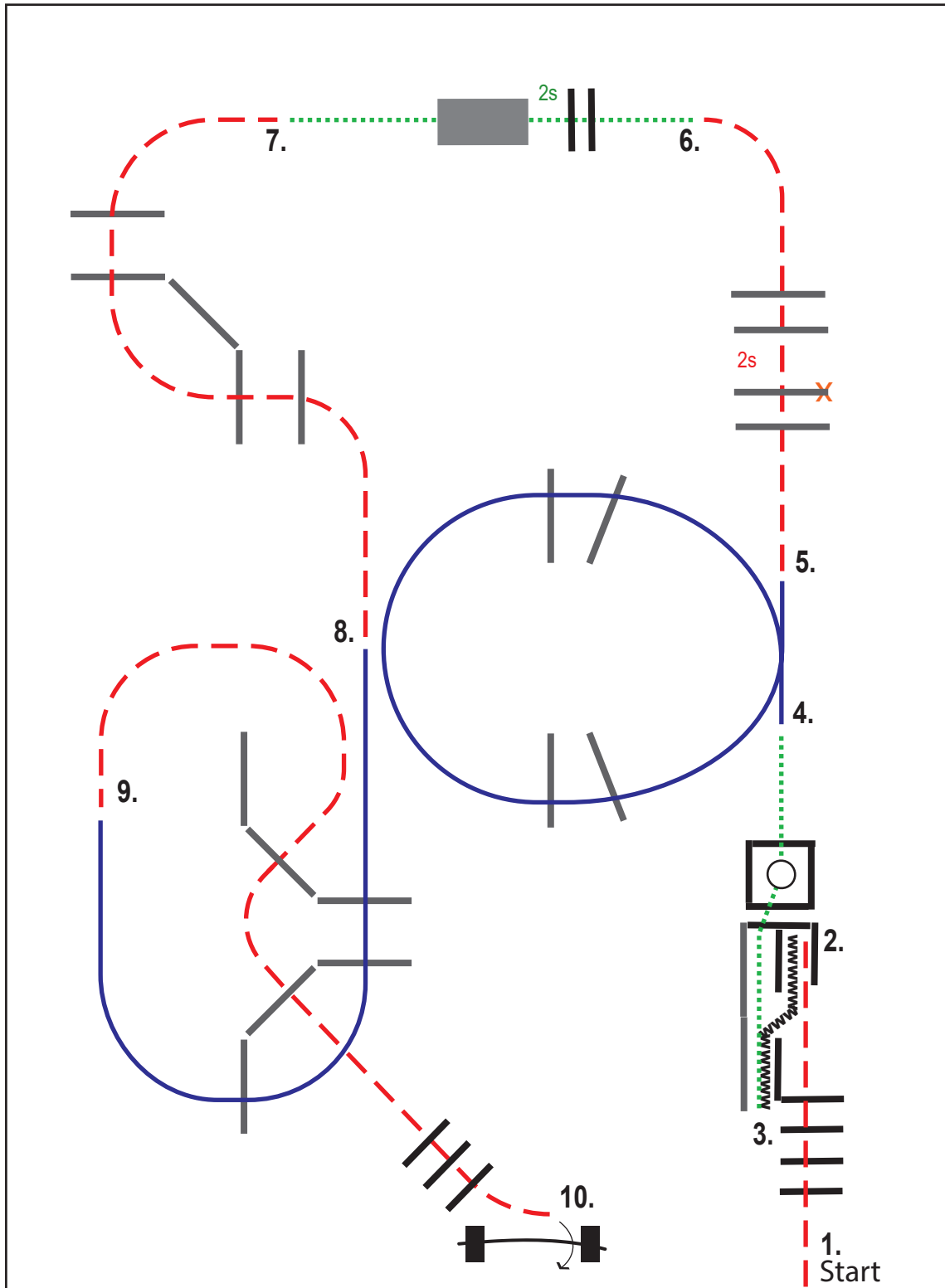

- 1. jog over poles into chute
- 2. back up
- 3. walk over into the box, turn 360° either way
- 4. lope over poles left lead
- 5. jog over poles

- 6. walk over poles and bridge
- 7. jog over poles
- 8. lope over poles right lead
- 9. jog over poles
- 10. gate right hand

- Schritt
- - - Trab
- Galopp
- MMM** Rückwärts
- Seitwärts
- Pylonen
- X** Erhöhungen
- Tor



designed by Nina Zwölfer

CWN-C ZNS / Österreichische Meisterschaften
 Wr. Neustadt/NÖ * 27.05. - 29.05.2023
 041 Trail Novice Youth

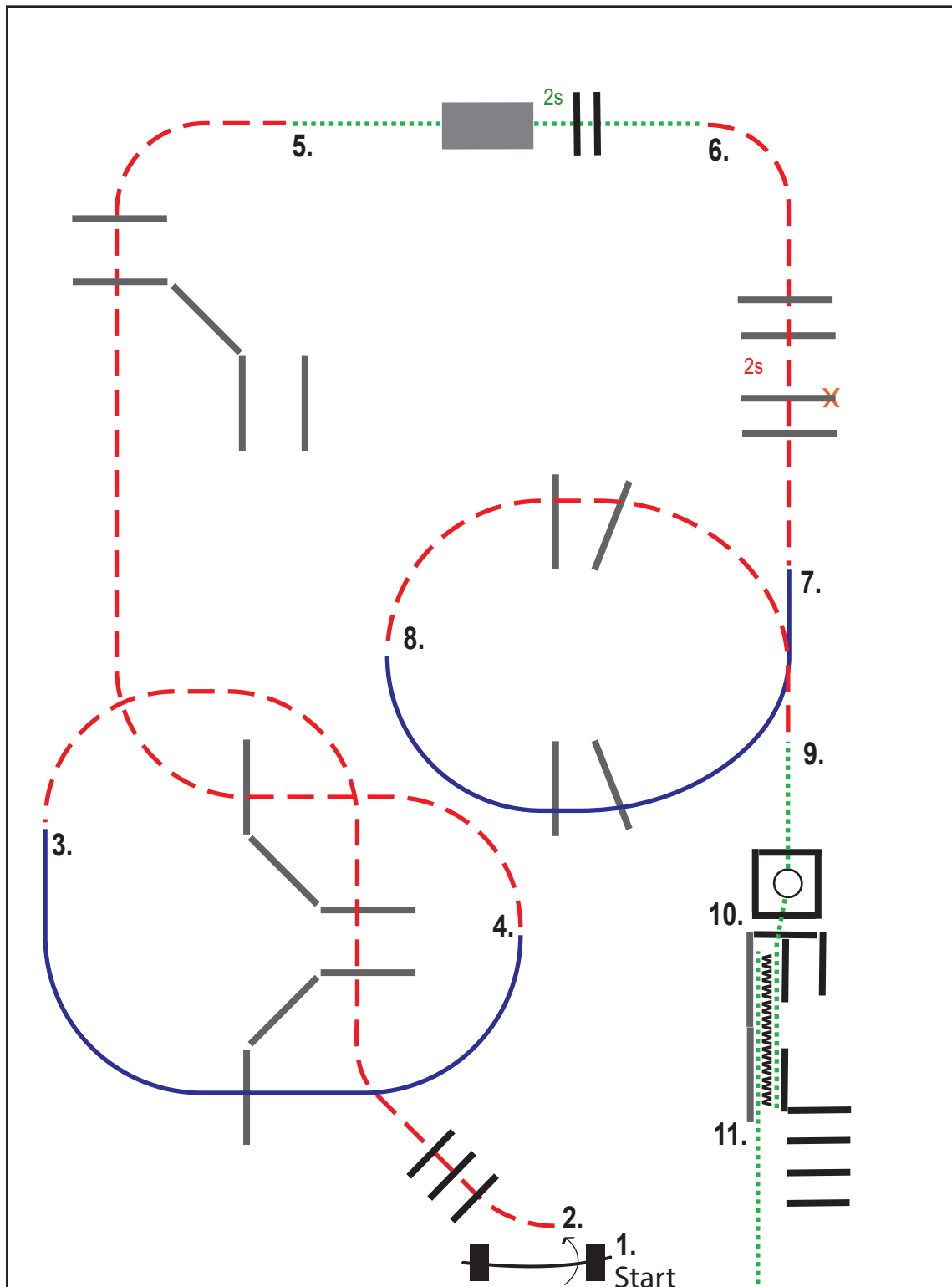

- 1. gate left hand
- 2. jog over poles
- 3. lope over poles left lead
- 4. jog over poles
- 5. walk over bridge and poles
- 6. jog over poles

- 7. lope over poles right lead
- 8. jog over poles
- 9. walk into the box, turn 360° either way
- 10. walk over poles into chute
- 11. back up and walk out

- Schrittl
- - - Trab
- Galopp
- MMM** Rückwärts

- Seitwärts
- Pylonen
- Erhöhungen
- Tor



designed by Nina Zwölfer

CWN-C ZNS / Österreichische Meisterschaften
 Wr. Neustadt/NÖ * 27.05. - 29.05.2023
 042 Trail Open & 043 Trail Open ÖM Vorlauf

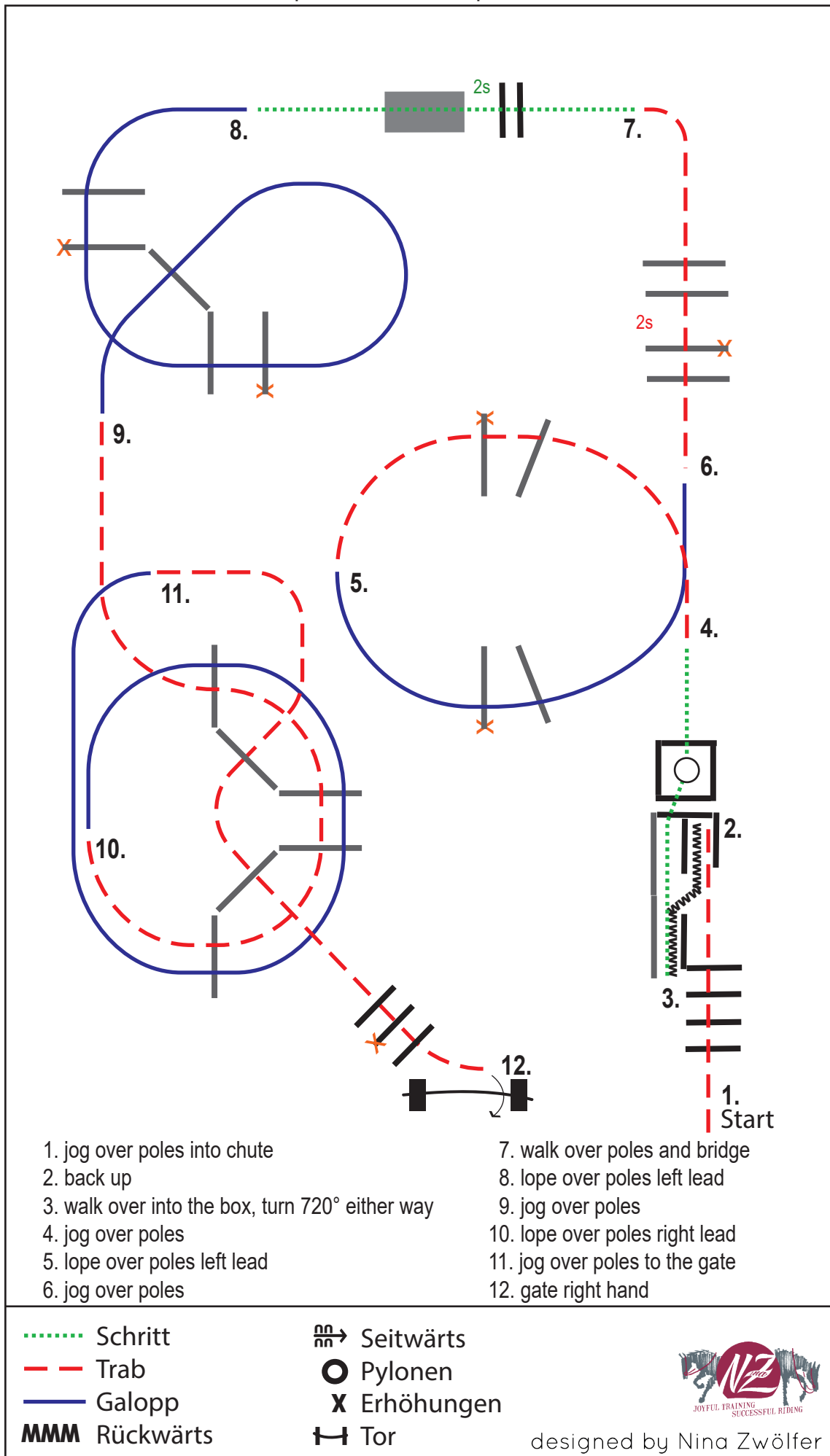

CWN-C ZNS / Österreichische Meisterschaften
 Wr. Neustadt/NÖ * 27.05. - 29.05.2023
 044 Trail Kids Führzügel

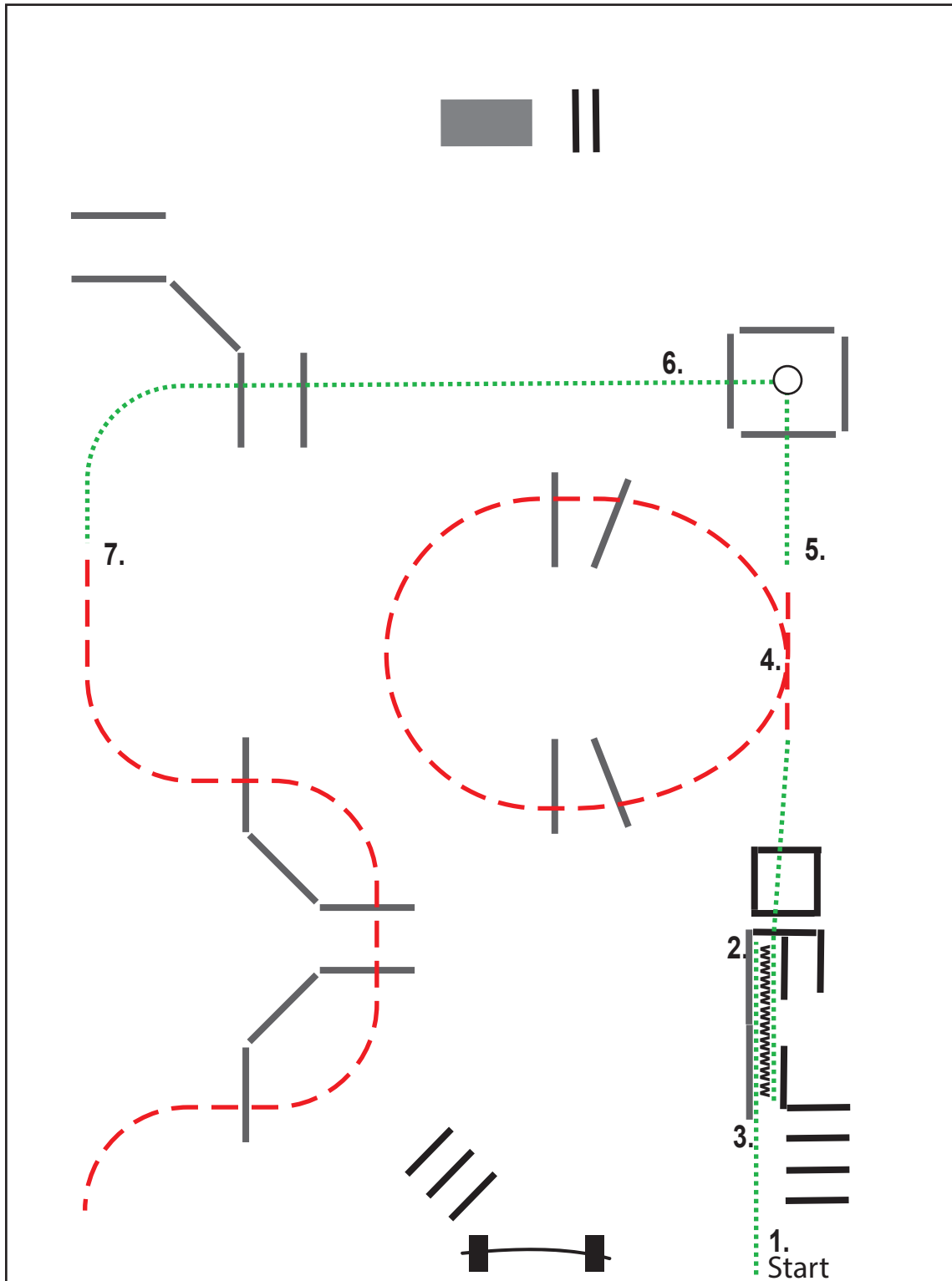

- 1. walk over poles into chute
- 2. back up
- 3. walk over pole and box
- 4. jog over poles

- 5. walk into box, turn 270° right
- 6. walk over poles
- 7. jog over poles

Schritt	Seitwärts
Trab	Pylonen
Galopp	Erhöhungen
Rückwärts	Tor



designed by Nina Zwölfer

CWN-C ZNS / Österreichische Meisterschaften
 Wr. Neustadt/NÖ * 27.05. - 29.05.2023
 045 Trail Youngster

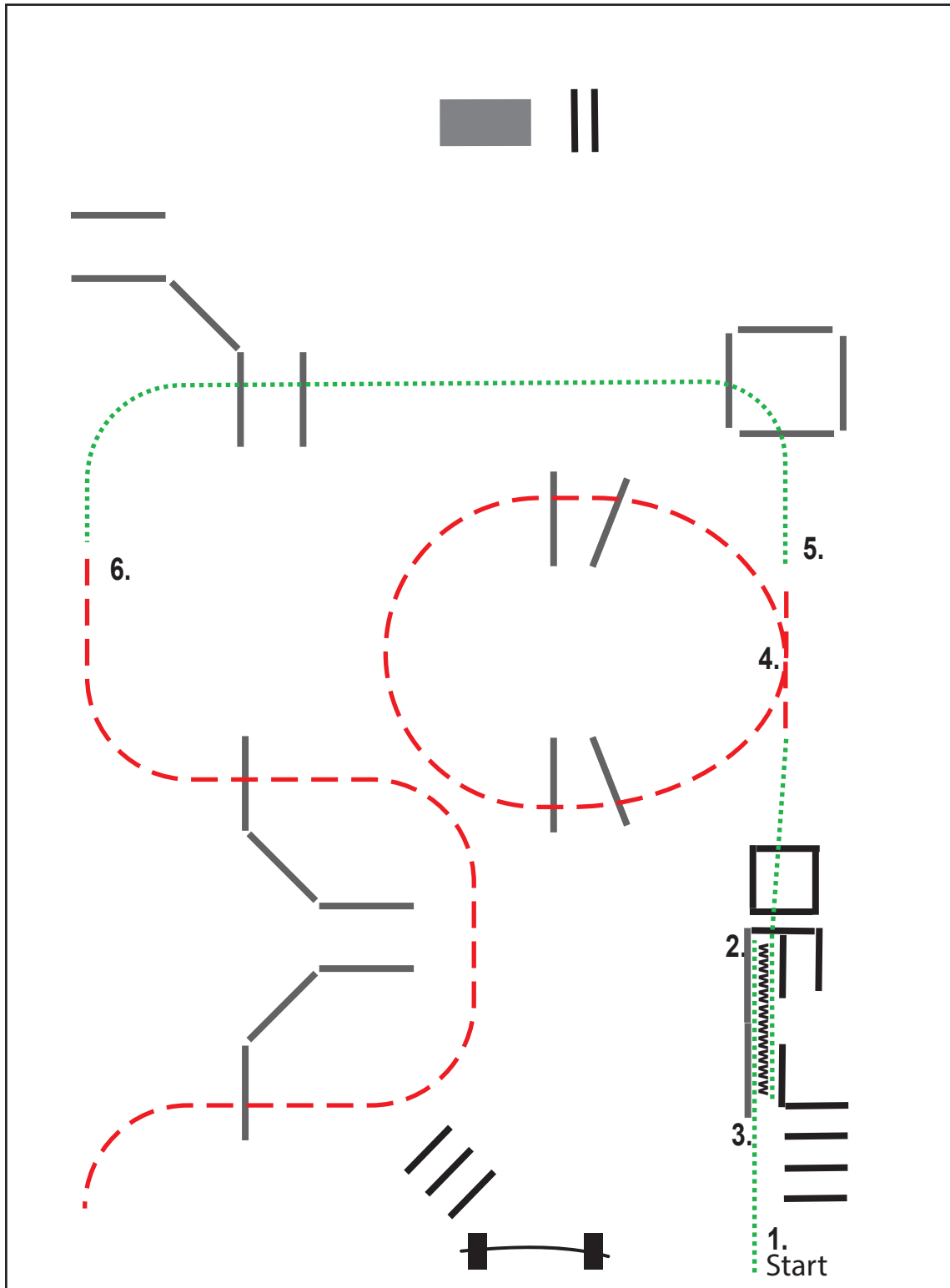

- | | |
|-------------------------------|--------------------|
| 1. walk over poles into chute | 4. jog over poles |
| 2. back up | 5. walk over poles |
| 3. walk over pole and box | 6. jog over poles |
| 4. jog over poles | |

Schritt	Seitwärts
Trab	Pylonen
Galopp	Erhöhungen
Rückwärts	Tor



designed by Nina Zwölfer

CWN-C ZNS / Österreichische Meisterschaften
 Wr. Neustadt/NÖ * 27.05. - 29.05.2023
 082 Trail Youth

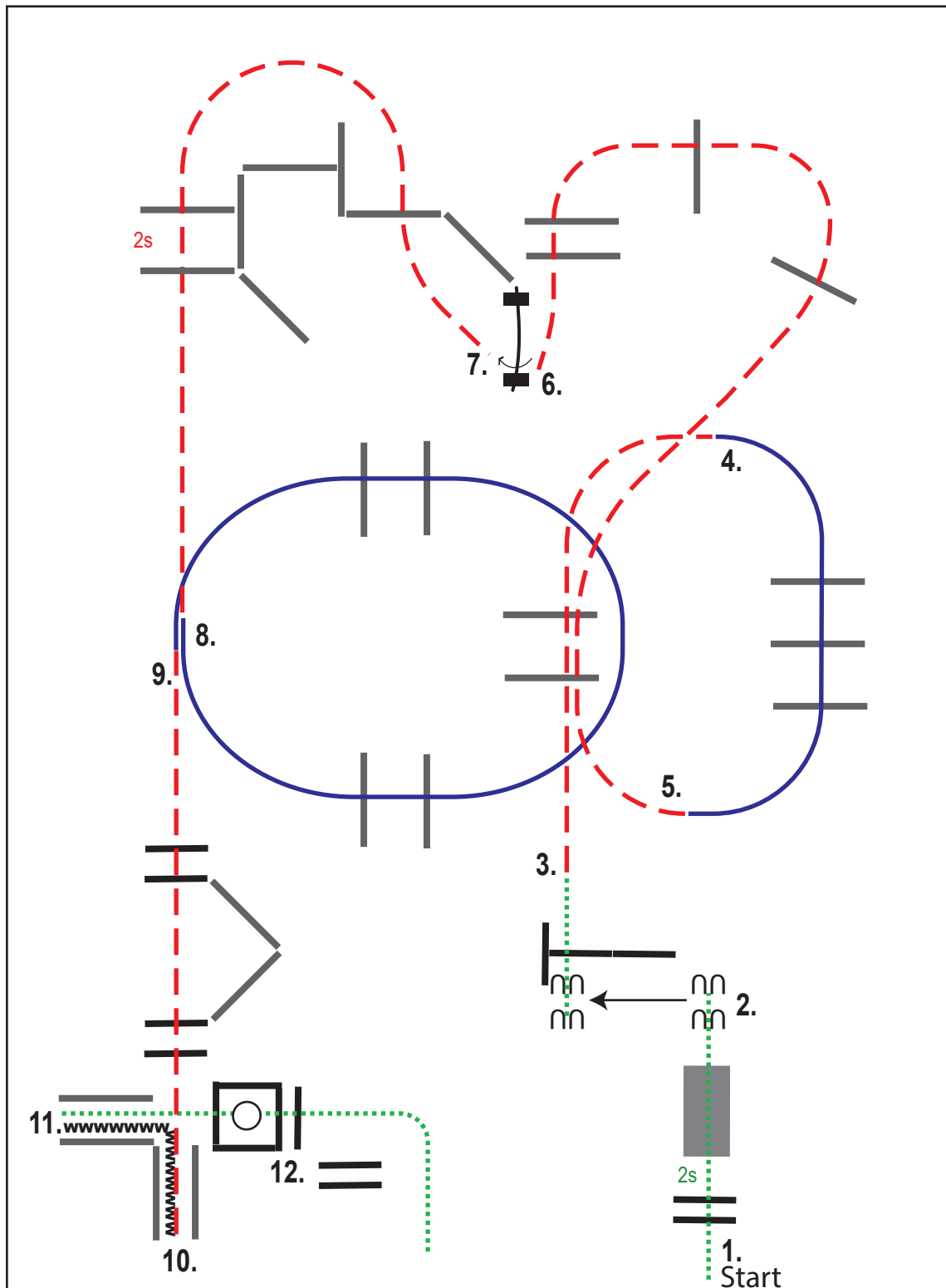

- | | |
|-------------------------------|--|
| 1. walk over poles and bridge | 7. jog over poles |
| 2. sidepass left, walk over | 8. lope over poles left lead |
| 3. jog over poles | 9. jog over poles into chute |
| 4. lope over poles right lead | 10. back up „L“ |
| 5. jog over poles to gate | 11. walk over poles into box, turn 360° either way |
| 6. gate right hand | 12. walk over poles |

- | | |
|----------------|----------------|
| Schritt | nn → Seitwärts |
| - - - - - Trab | ○ Pylonen |
| ———— Galopp | X Erhöhungen |
| MMM Rückwärts | ⊥ Tor |



designed by Nina Zwölfer

CWN-C ZNS / Österreichische Meisterschaften
 Wr. Neustadt/NÖ * 27.05. - 29.05.2023
 083 Trail Novice Amateur

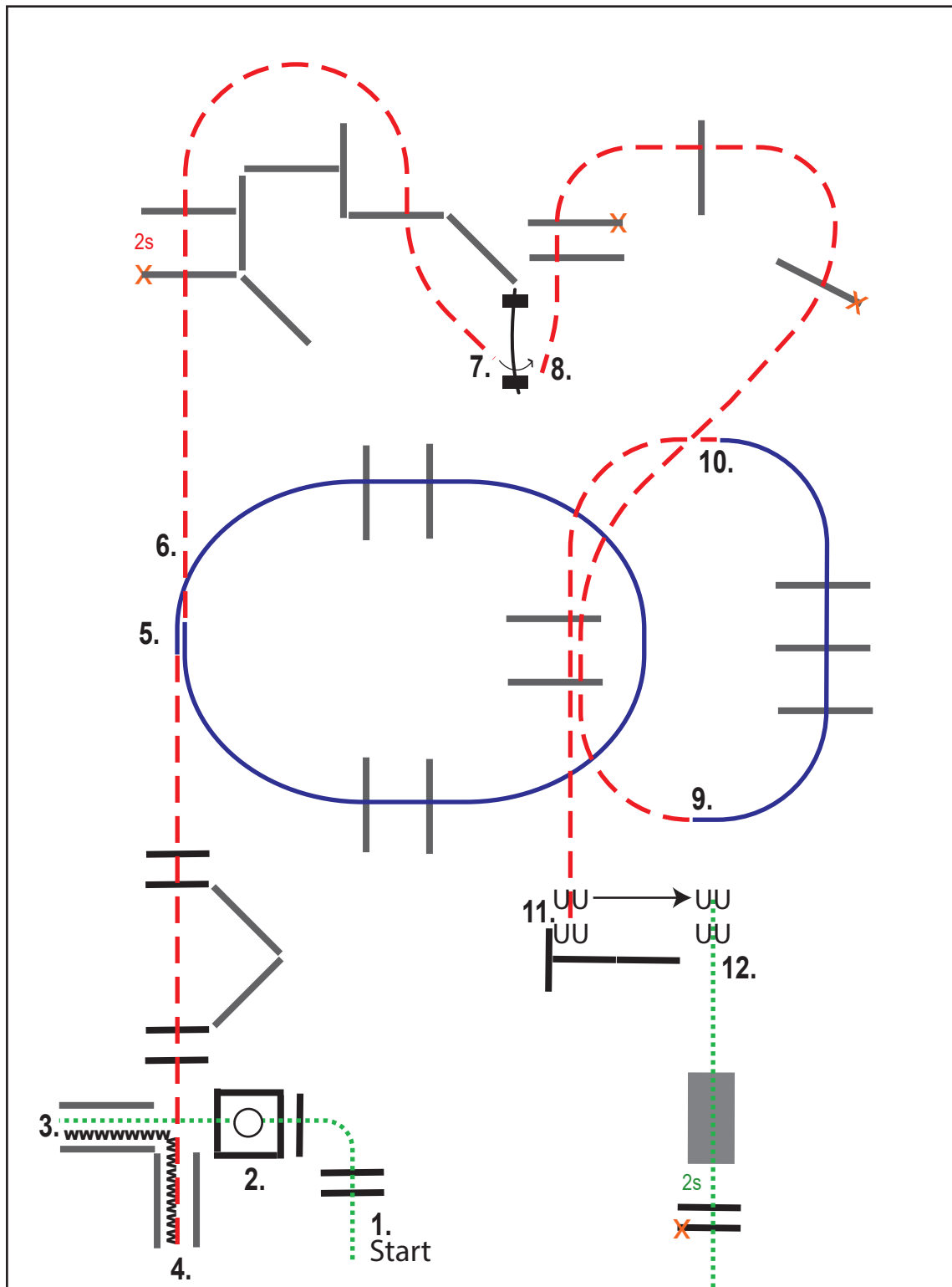

- 1. walk over poles into box
- 2. turn 360° either way, walk into chute
- 3. back up „L“
- 4. jog over poles
- 5. lope over poles right lead
- 6. jog over poles to gate

- 7. gate left hand
- 8. jog over poles
- 9. lope over poles left lead
- 10. jog over poles
- 11. stop, sidepass left
- 12. walk over bridge and poles

- Schritt
- - - - - Trab
- Galopp
- MMM Rückwärts
- ↔ Seitwärts
- Pylonen
- X Erhöhungen
- ⊢ Tor



designed by Nina Zwölfer

CWN-C ZNS / Österreichische Meisterschaften
 Wr. Neustadt/NÖ * 27.05. - 29.05.2023
 084 Trail Amateur

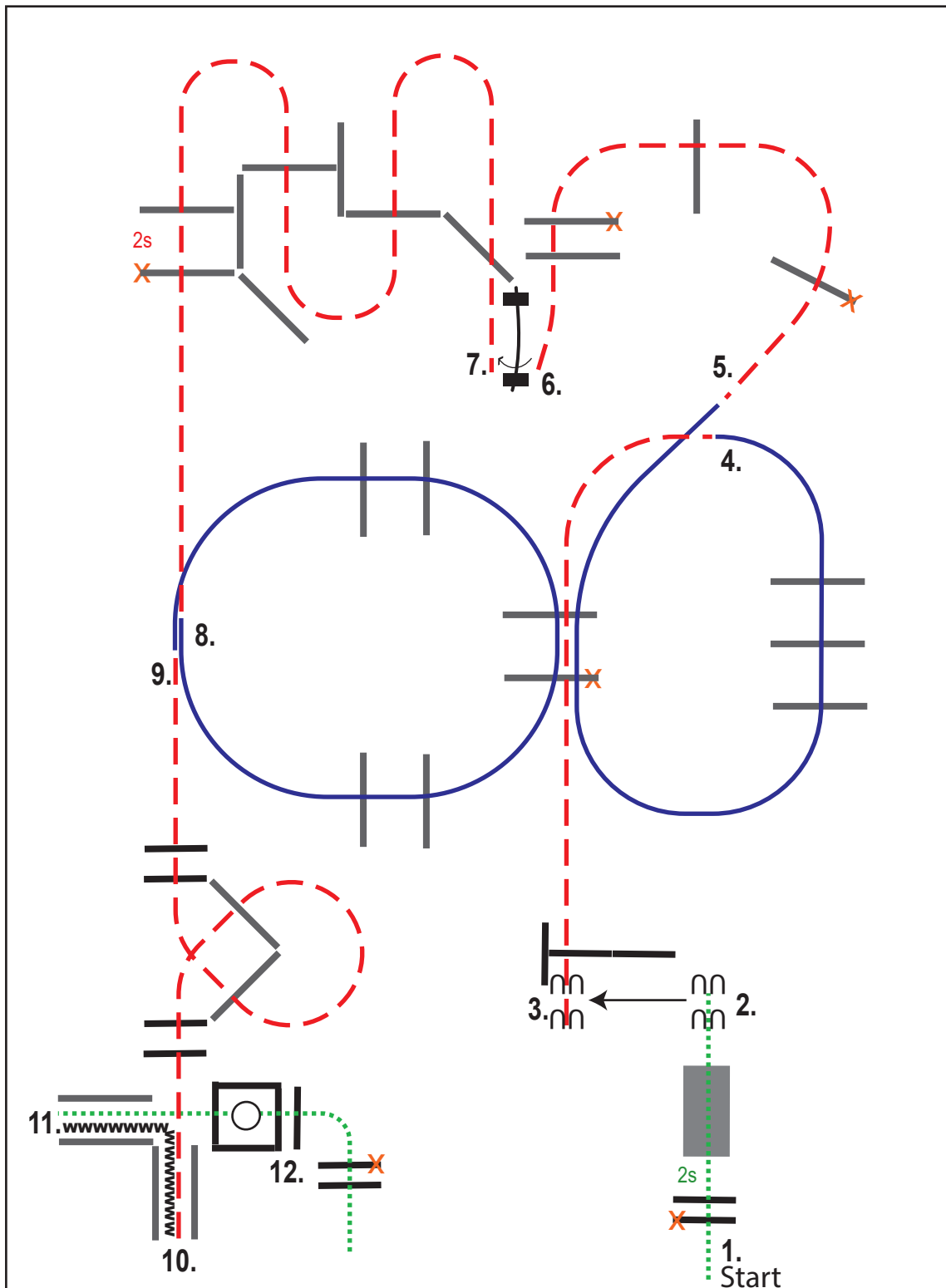

- | | |
|-------------------------------|--|
| 1. walk over poles and bridge | 7. jog over poles |
| 2. sidepass left | 8. lope over poles left lead |
| 3. jog over poles | 9. jog over poles |
| 4. lope over poles right lead | 10. back up „L“ |
| 5. jog over poles to gate | 11. walk over poles into box, turn 720° either way |
| 6. gate right hand | 12. walk over poles |

- | | |
|----------------|--------------|
| Schritt | ↔ Seitwärts |
| - - - - - Trab | ○ Pylonen |
| ———— Galopp | X Erhöhungen |
| MMM Rückwärts | ⊢ Tor |



designed by Nina Zwölfer

CWN-C ZNS / Österreichische Meisterschaften
 Wr. Neustadt/NÖ * 27.05. - 29.05.2023
 084 Trail Open ÖM Finale

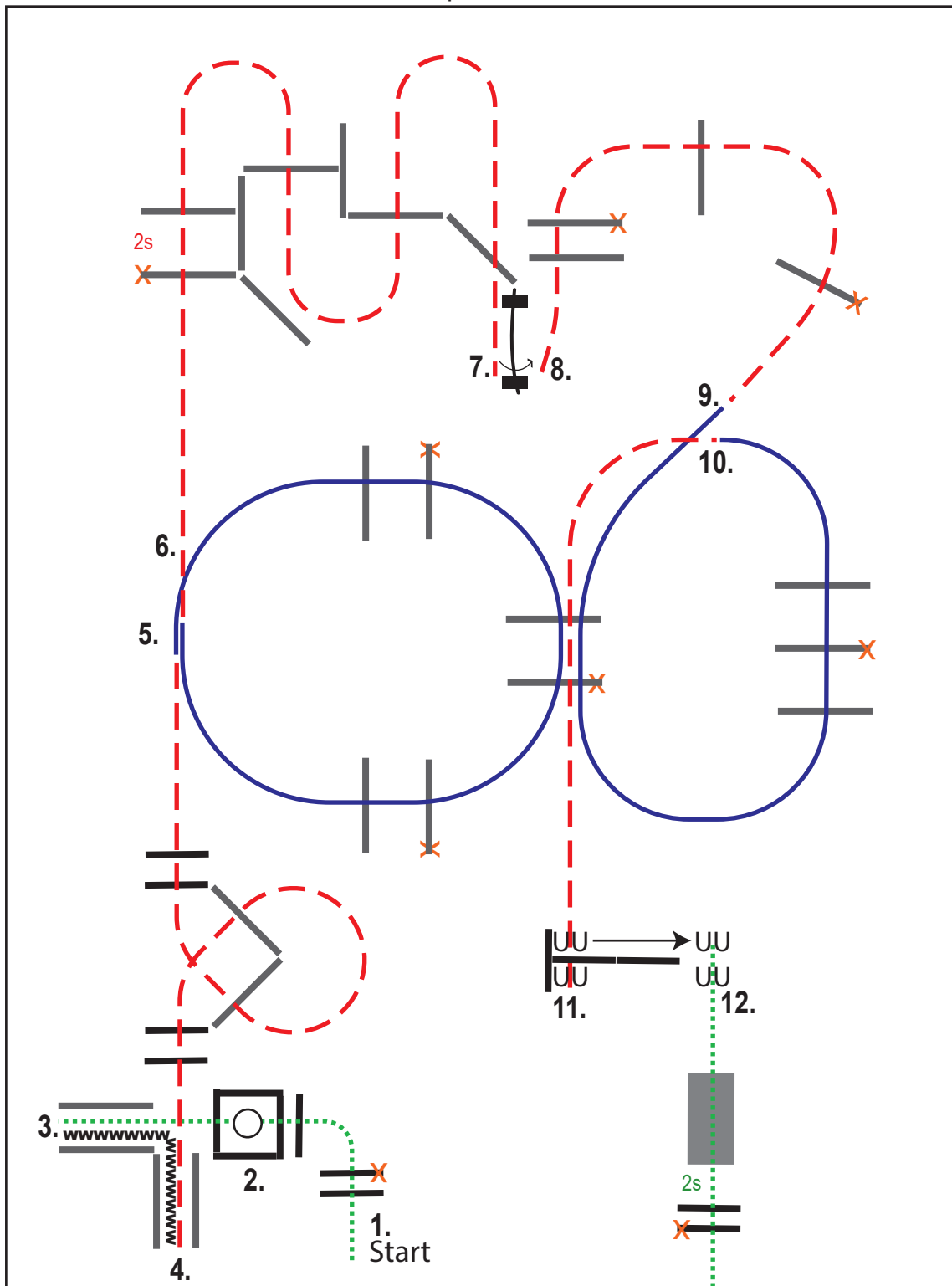

1. walk over poles into box
2. turn 720° either way, walk into chute
3. back up „L“
4. jog over poles
5. lope over poles right lead
6. jog over poles to gate

7. gate left hand
8. jog over poles
9. lope over poles left lead
10. jog over poles
11. stop over pole, sidepass left
12. walk over bridge and poles

- Schritt
- Trab
- Galopp
- MMM** Rückwärts
- \overrightarrow{nn} Seitwärts
- O** Pylonen
- X** Erhöhungen
- T** Tor



designed by Nina Zwölfer