

CWN-C ZNS & NRHA Show/AWA Championship/B LM/WTC Cup
 Wr. Neustadt/NÖ * 03.08. - 06.08.2023
 010 Horsemanship Open

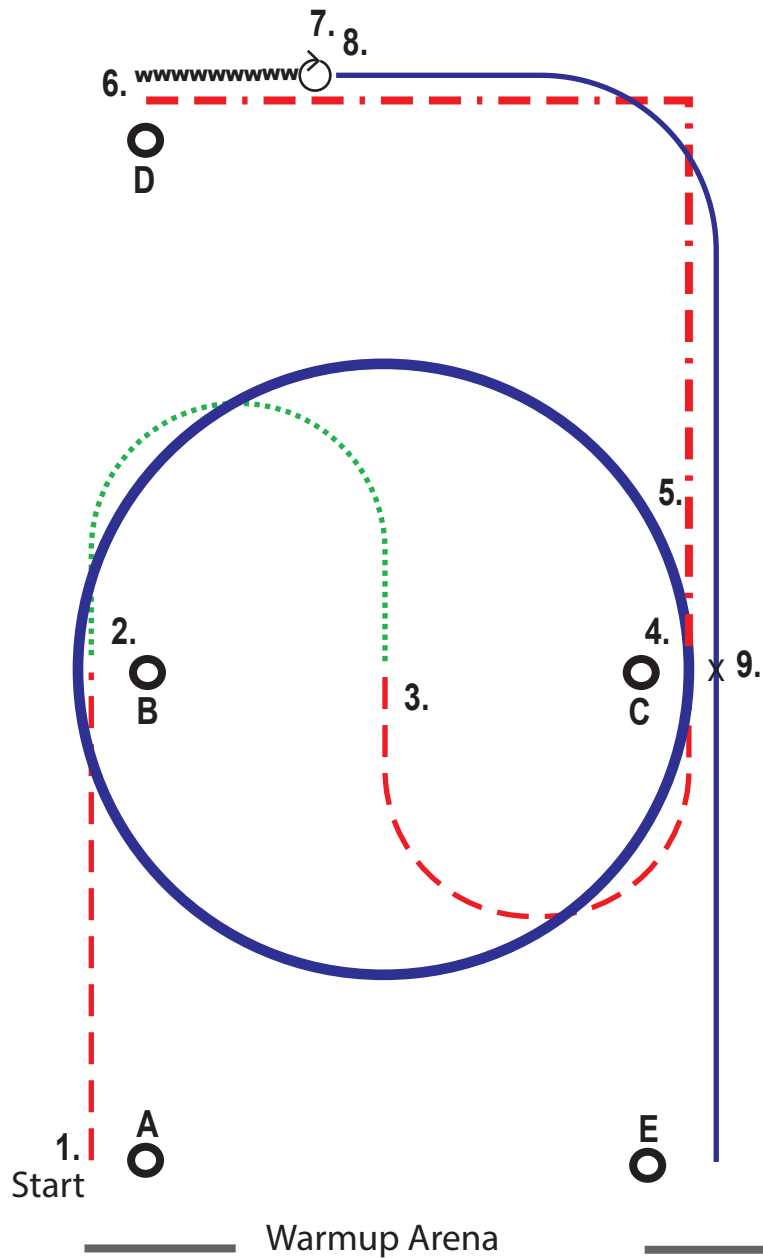

Be ready at marker A

- | | |
|---|---|
| 1. jog to B | 6. stop, back up at least one horse length |
| 2. walk half circle | 7. perform 1 1/2 turn right |
| 3. jog small circle to C | 8. lope right lead to C |
| 4. extended lope left lead one big circle | 9. lead change, left lope to E |
| 5. extended jog from C to D | pattern is completed, exit at the walk or jog |

- | | |
|----------------------------|------------------|
| Schritt | MM backup |
| - - - - - Trab | sidepass |
| - . - . - verstärkter Trab | marker |
| ———— Galopp | Center of Arena |
| ———— verstärkter Galopp | |



designed by Nina Zwölfer

CWN-C ZNS & NRHA Show/AWA Championship/B LM/WTC Cup
 Wr. Neustadt/NÖ * 03.08. - 06.08.2023
 011 Horsemanship Amateur

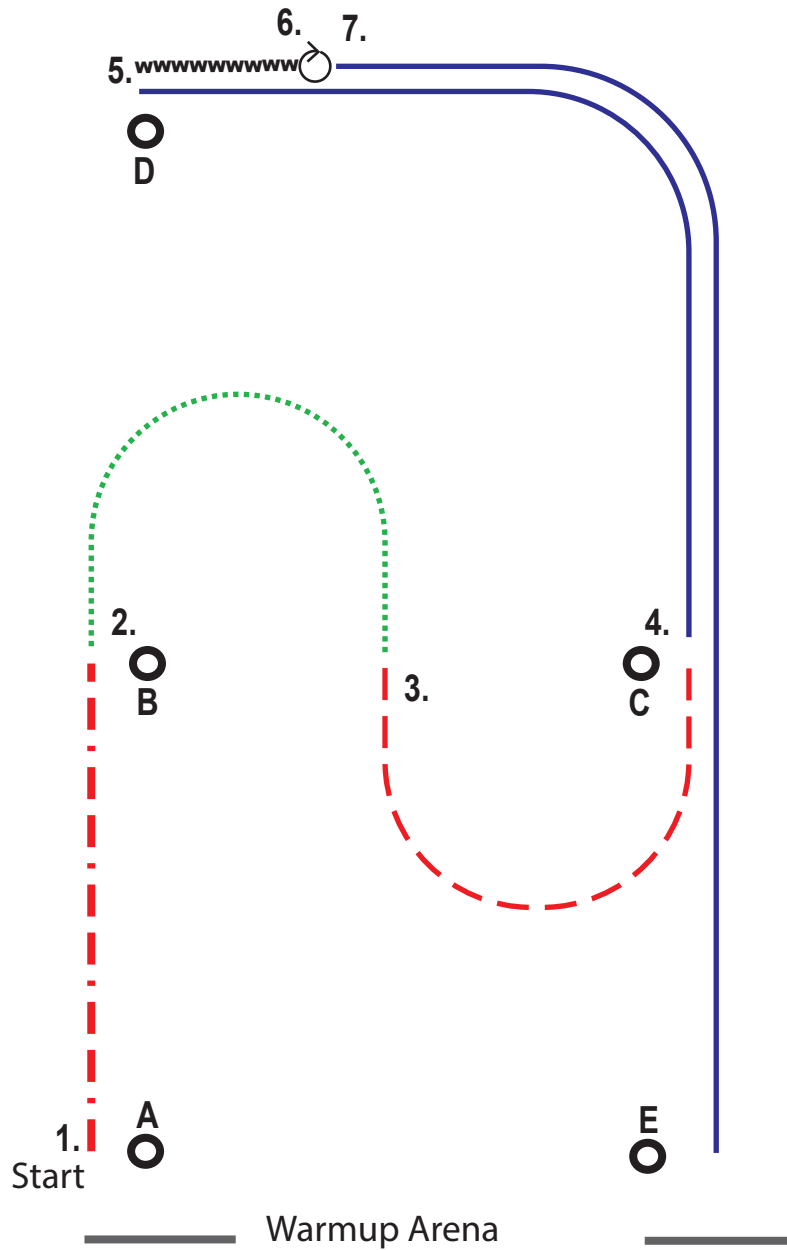

Be ready at marker A

1. extended jog to B
2. walk half circle
3. jog small circle to C
4. lope left lead to D

5. stop, back up at least one horse length
6. perform 1 1/2 turn right
7. lope right lead to E

pattern is completed, exit at the walk or jog

- | | |
|----------------------------|-------------------|
| Schritt | MM backup |
| - - - - - Trab | MM → sidepass |
| - . - . - verstärkter Trab | ⊙ marker |
| ———— Galopp | ⊗ Center of Arena |
| ———— verstärkter Galopp | |



designed by Nina Zwölfer

CWN-C ZNS & NRHA Show/AWA Championship/B LM/WTC Cup
 Wr. Neustadt/NÖ * 03.08. - 06.08.2023
 012 Horsemanship Novice Amateur

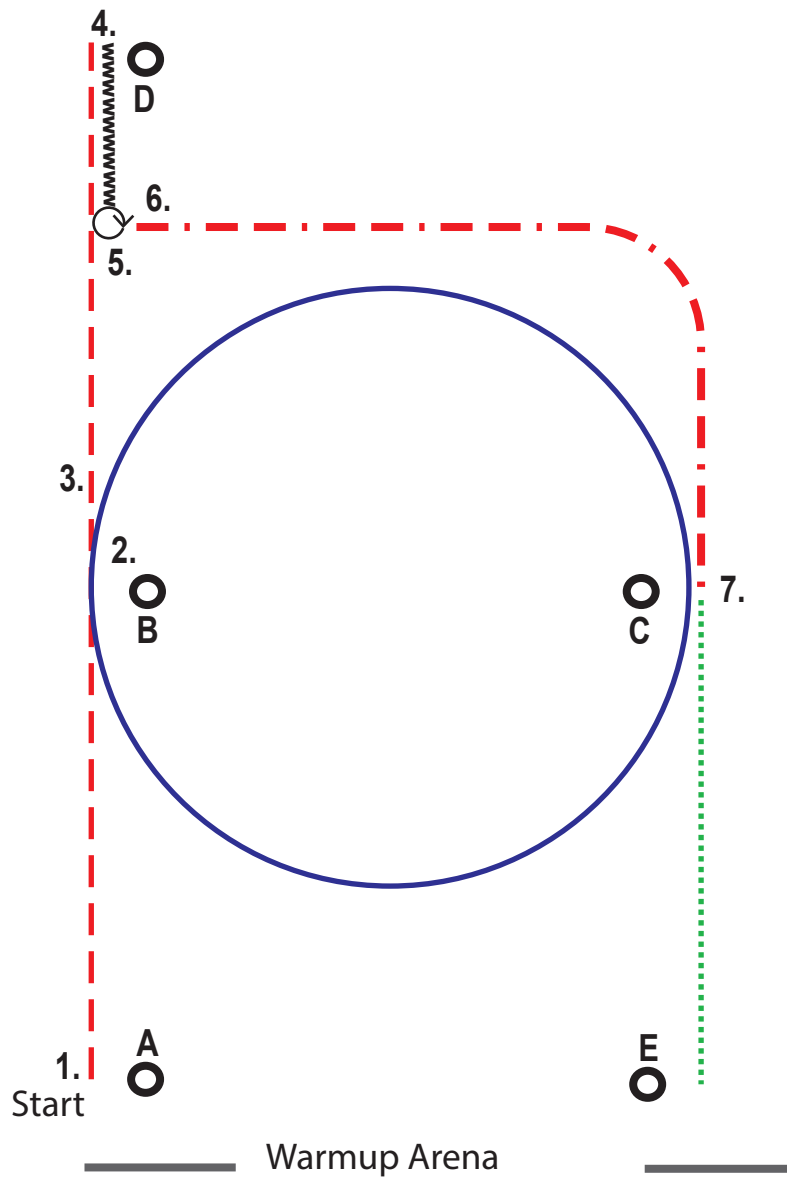

Be ready at marker A

1. jog to B
2. lope right lead 1 big circle
3. jog to D
4. stop, back up at least one horse length

5. perform 1 1/4 turn right

6. extended jog to C
7. walk to E

pattern is completed, exit at the walk or jog

- | | |
|----------------------------|-------------------|
| Schritt | MM backup |
| - - - - - Trab | MM → sidepass |
| - . - . - verstärkter Trab | ○ marker |
| ———— Galopp | × Center of Arena |
| ———— verstärkter Galopp | |



designed by Nina Zwölfer

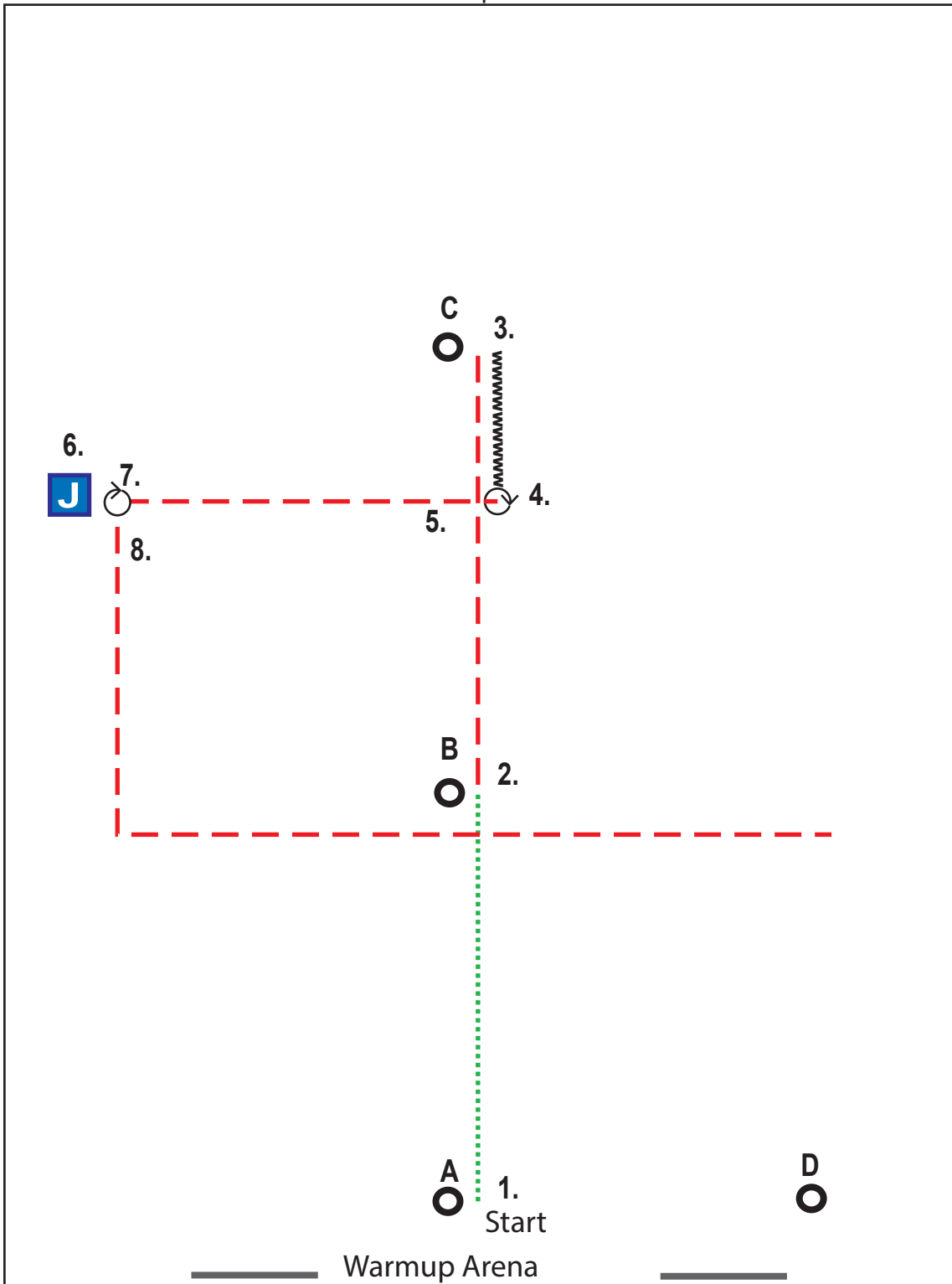

Warmup Arena

- Be ready at marker A
- 1. walk to B
 - 2. trot to C
 - 3. stop, back up at least one horse length
 - 4. perform 1 3/4 turn right
 - 5. trot straight line to Judge and set up for Inspection
 - 6. Inspection
 - 7. when dismissed perform 360° turn right
 - 8. trot one square corner
- pattern is completed, exit at the walk or jog

..... Schrittl	MM backup
- - - Trab	MM → sidepass
- . - verstärkter Trab	○ marker
— Galopp	× Center of Arena
— verstärkter Galopp	



designed by Nina Zwölfer

CWN-C ZNS & NRHA Show/AWA Championship/B LM/WTC Cup
 Wr. Neustadt/NÖ * 03.08. - 06.08.2023
 042 Horsemanship Youth

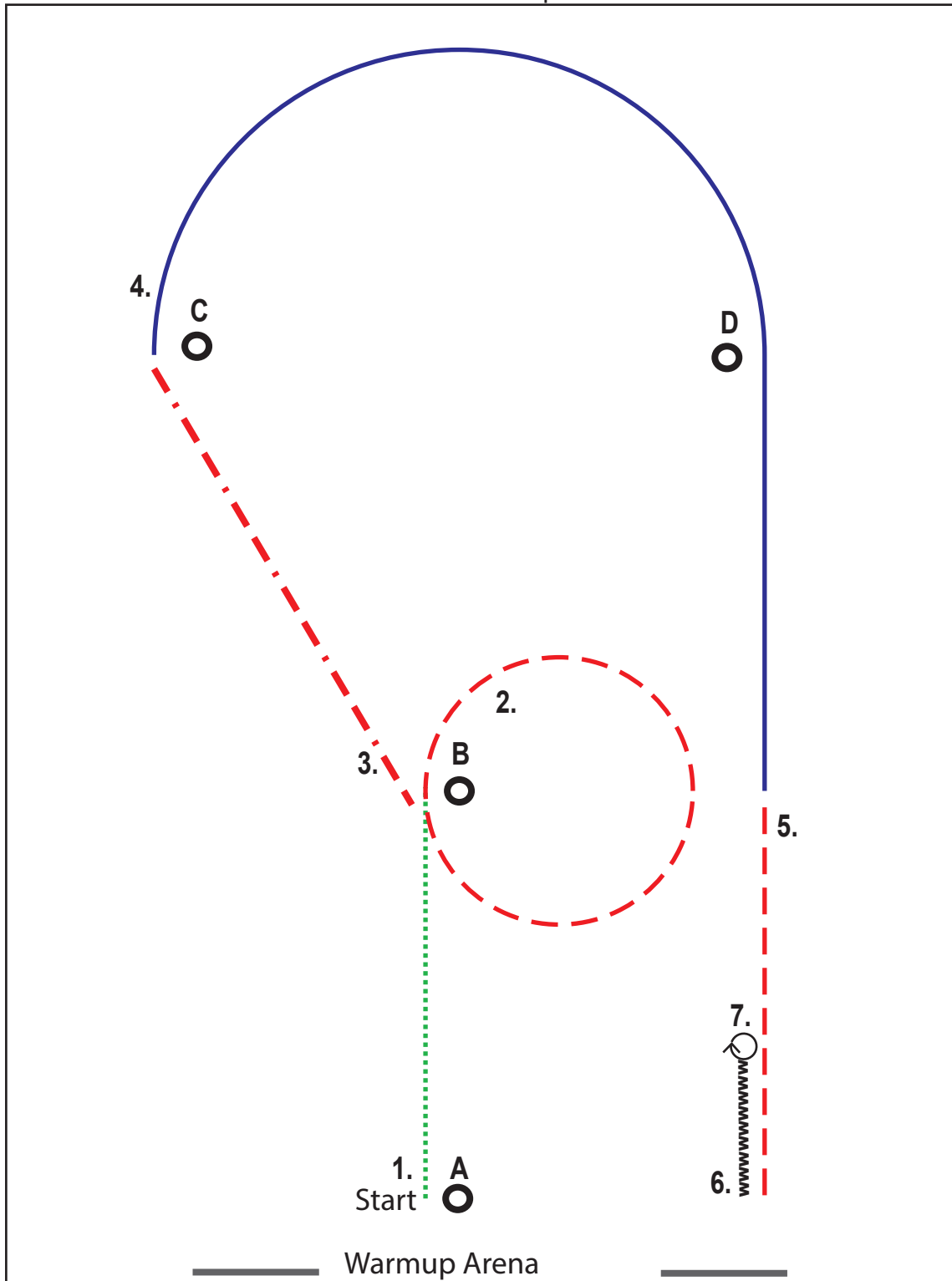

- Be ready at marker A
1. walk to B
 2. jog 1 small circle
 3. extended jog to C
 4. lope right lead

5. jog
6. stop, back up at least one horse length
7. perform 1 turn either way

pattern is completed, exit at the walk or jog

- | | |
|--------------------------|-------------------|
| Schrittl | MM backup |
| - - - - Trab | MM → sidepass |
| - . - . verstärkter Trab | ○ marker |
| ———— Galopp | ⊗ Center of Arena |
| ———— verstärkter Galopp | |



designed by Nina Zwölfer

CWN-C ZNS & NRHA Show/AWA Championship/B LM/WTC Cup
 Wr. Neustadt/NÖ * 03.08. - 06.08.2023
 043 Horsemanship Rookie Vorlauf

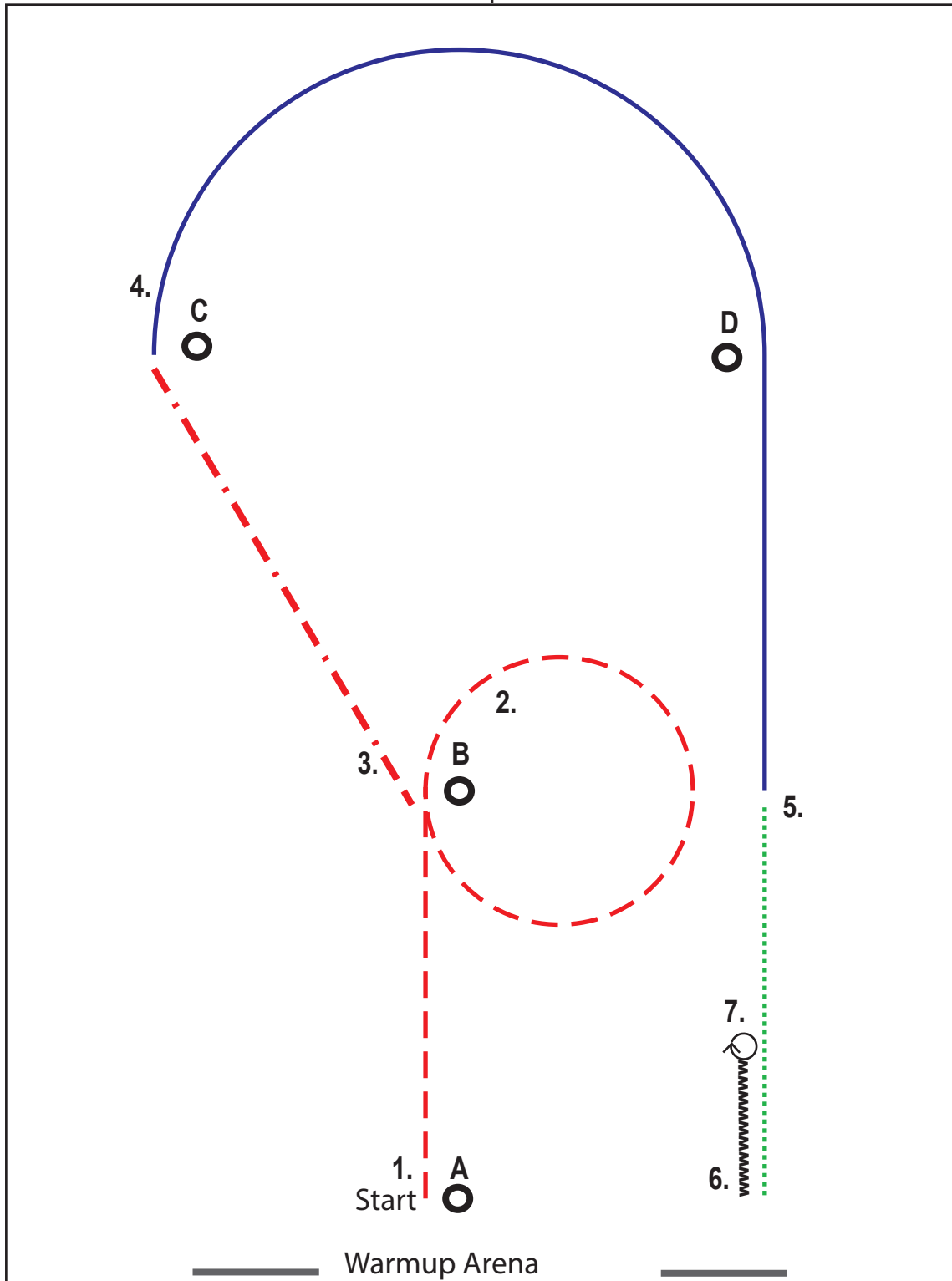

Be ready at marker A

1. jog to B
2. jog 1 small circle
3. extended jog to C
4. lope right lead

5. walk

6. stop, back up at least one horse length

7. perform 1 turn either way

pattern is completed, exit at the walk or jog

- Schritt
- - - - - Trab
- . - . - verstärkter Trab
- Galopp
- verstärkter Galopp

- MM backup
- MM → sidepass
- marker
- ⊗ Center of Arena



designed by Nina Zwölfer

CWN-C ZNS & NRHA Show/AWA Championship/B LM/WTC Cup
 Wr. Neustadt/NÖ * 03.08. - 06.08.2023
 066 Horsemanship Rookie Finale

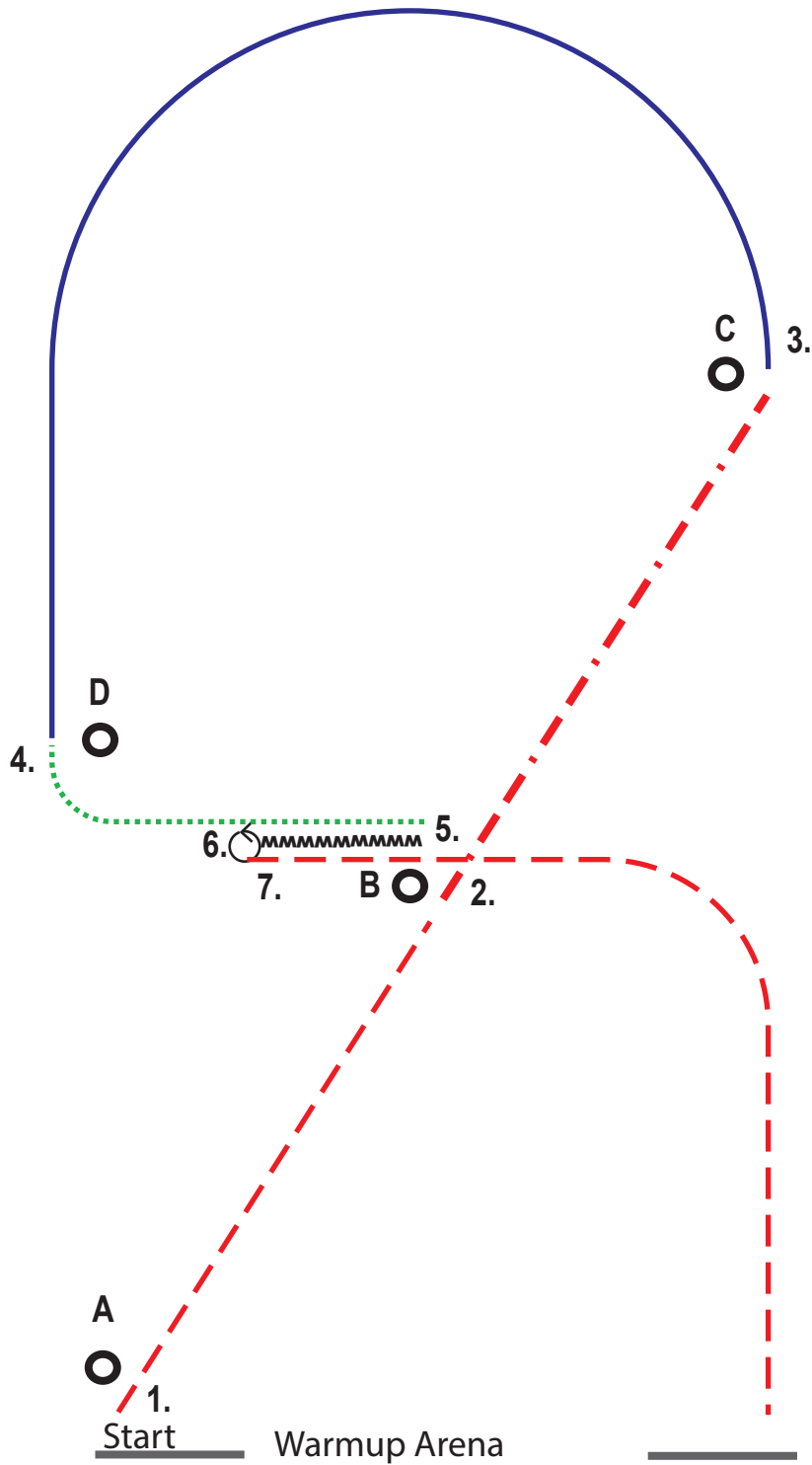

Be ready at marker A
 1. jog to B
 2. extended jog to C
 3. lope left lead to D
 4. walk from D to B

5. stop, back up at least one horse length
 6. perform 1 turn left
 7. jog

pattern is completed, exit at the walk or jog

- Schrittl
- - - - - Trab
- . - . - verstärkter Trab
- Galopp
- verstärkter Galopp
- MM backup
- MM → sidepass
- marker
- ⊗ Center of Arena



designed by Nina Zwölfer

CWN-C ZNS & NRHA Show/AWA Championship/B LM/WTC Cup
 Wr. Neustadt/NÖ * 03.08. - 06.08.2023
 066 Horsemanship Novice Amateur Finale

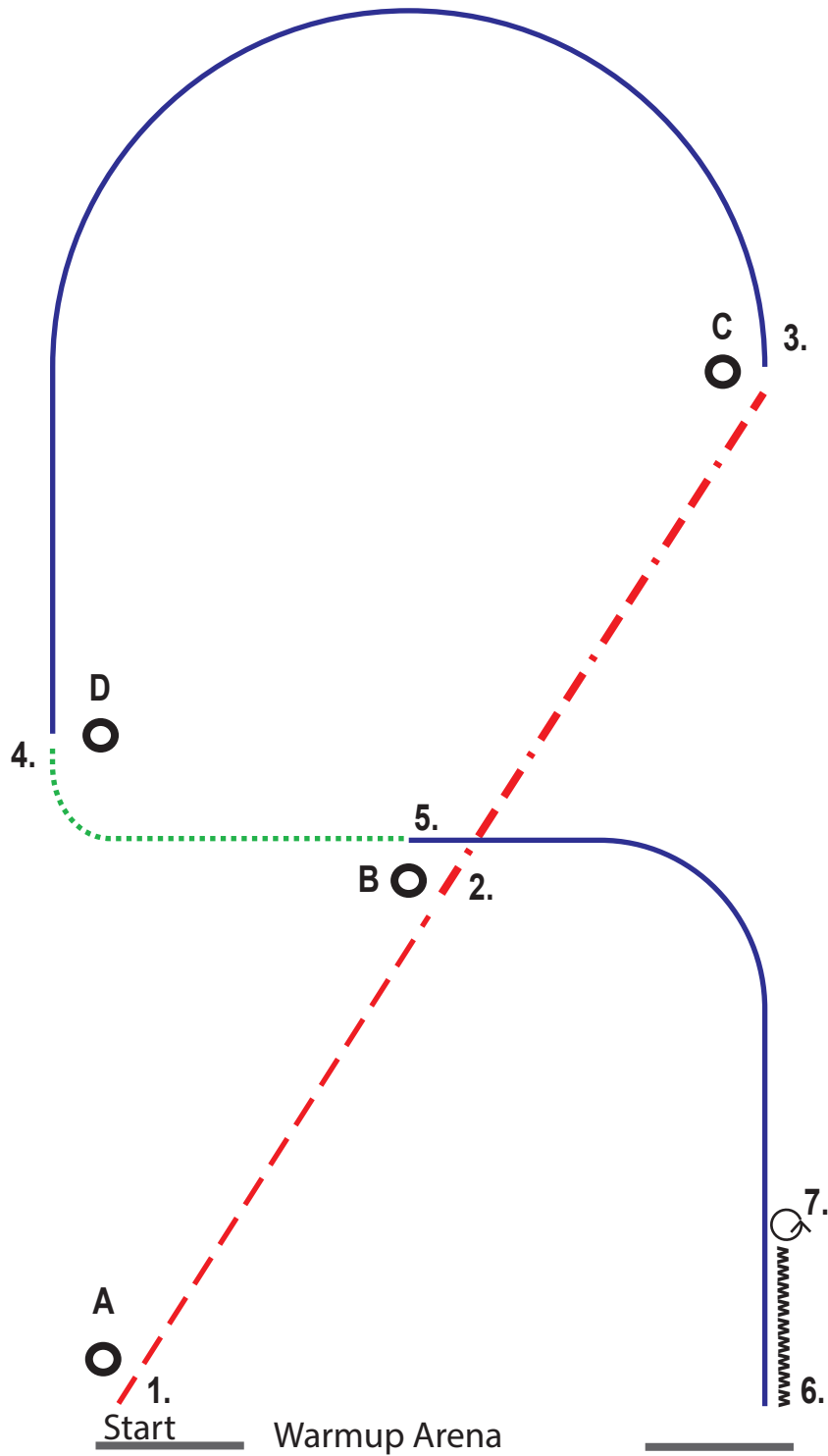

Be ready at marker A

1. jog to B
2. extended jog to C
3. lope left lead to D
4. walk to B

5. lope right lead

6. stop, back up at least one horse length

7. perform 1 turn left

pattern is completed, exit at the walk or jog

..... Schritt

--- Trab

- . - - verstärkter Trab

— Galopp

— verstärkter Galopp

MM backup

MM → sidepass

○ marker

⊗ Center of Arena



designed by Nina Zwölfer

CWN-C ZNS & NRHA Show/AWA Championship/B LM/WTC Cup
 Wr. Neustadt/NÖ * 03.08. - 06.08.2023
 100 Horsemanship Amateur

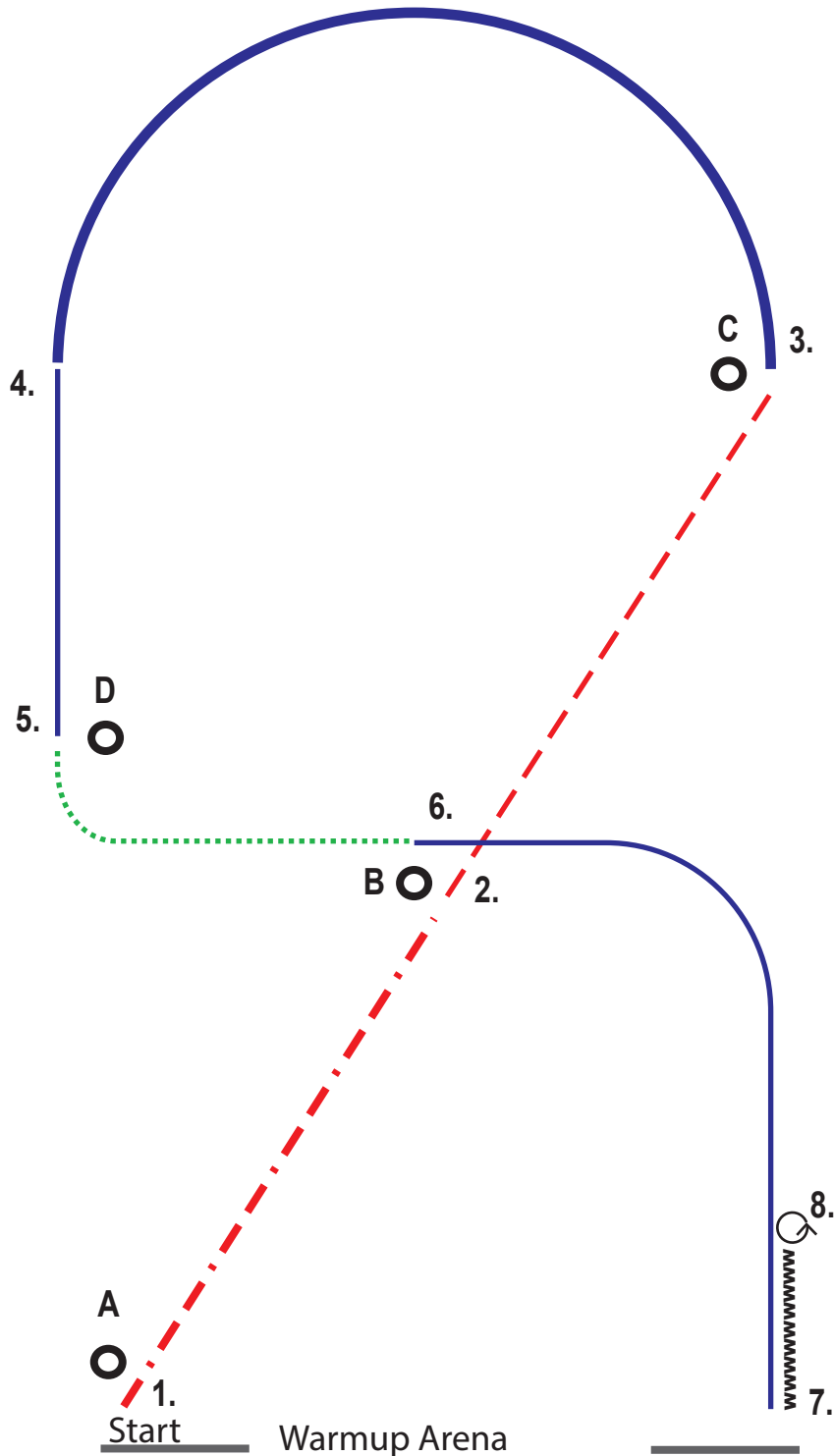

Be ready at marker A

1. extended jog to B
2. jog to C
3. extended lope left lead half circle
4. lope left lead to D

5. walk to B

6. lope right lead
 7. stop, back up at least one horse length
 8. perform 1 turn left
- pattern is completed, exit at the walk or jog

- Schritt
- - - - - Trab
- . - . - verstärkter Trab
- Galopp
- verstärkter Galopp

- MM backup
- sidepass
- marker
- ⊗ Center of Arena



designed by Nina Zwölfer

CWN-C ZNS & NRHA Show/AWA Championship/B LM/WTC Cup
 Wr. Neustadt/NÖ * 03.08. - 06.08.2023
 101 Horsemanship Youth

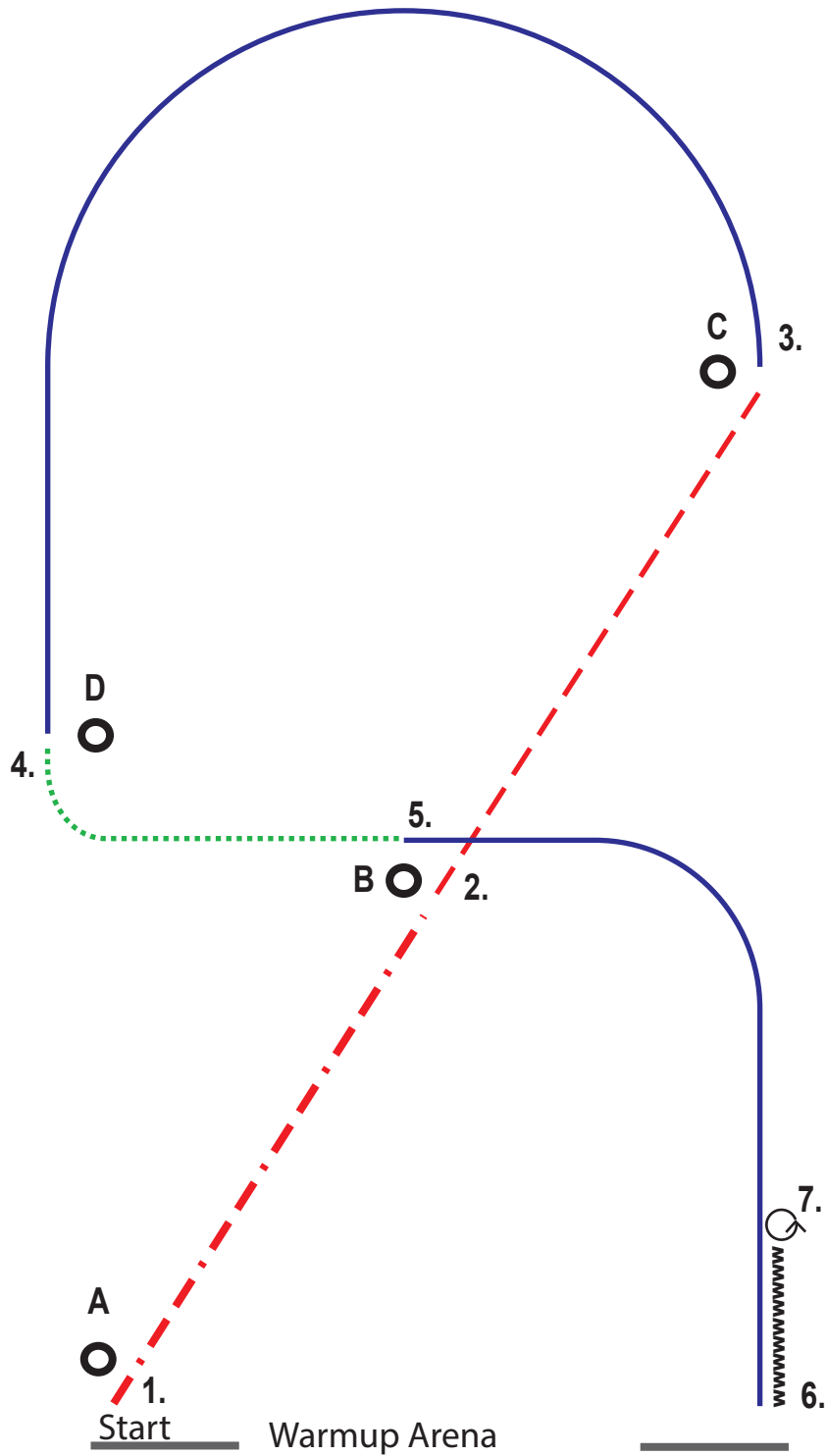

Be ready at marker A

1. extended jog to B
2. jog to C
3. lope left lead to D
4. walk to B

5. lope right lead

6. stop, back up at least one horse length
7. perform 1 turn either way

pattern is completed, exit at the walk or jog

- | | |
|----------------------------|-------------------|
| Schritt | MM backup |
| - - - - - Trab | MM → sidepass |
| - . - . - verstärkter Trab | ○ marker |
| ———— Galopp | ⊗ Center of Arena |
| ———— verstärkter Galopp | |



designed by Nina Zwölfer