

CWN-C ZNS & NRHA Show/AWA Championship/B LM/WTC Cup
 Wr. Neustadt/NÖ * 03.08. - 06.08.2023
 001 Trail Rookie Vorlauf

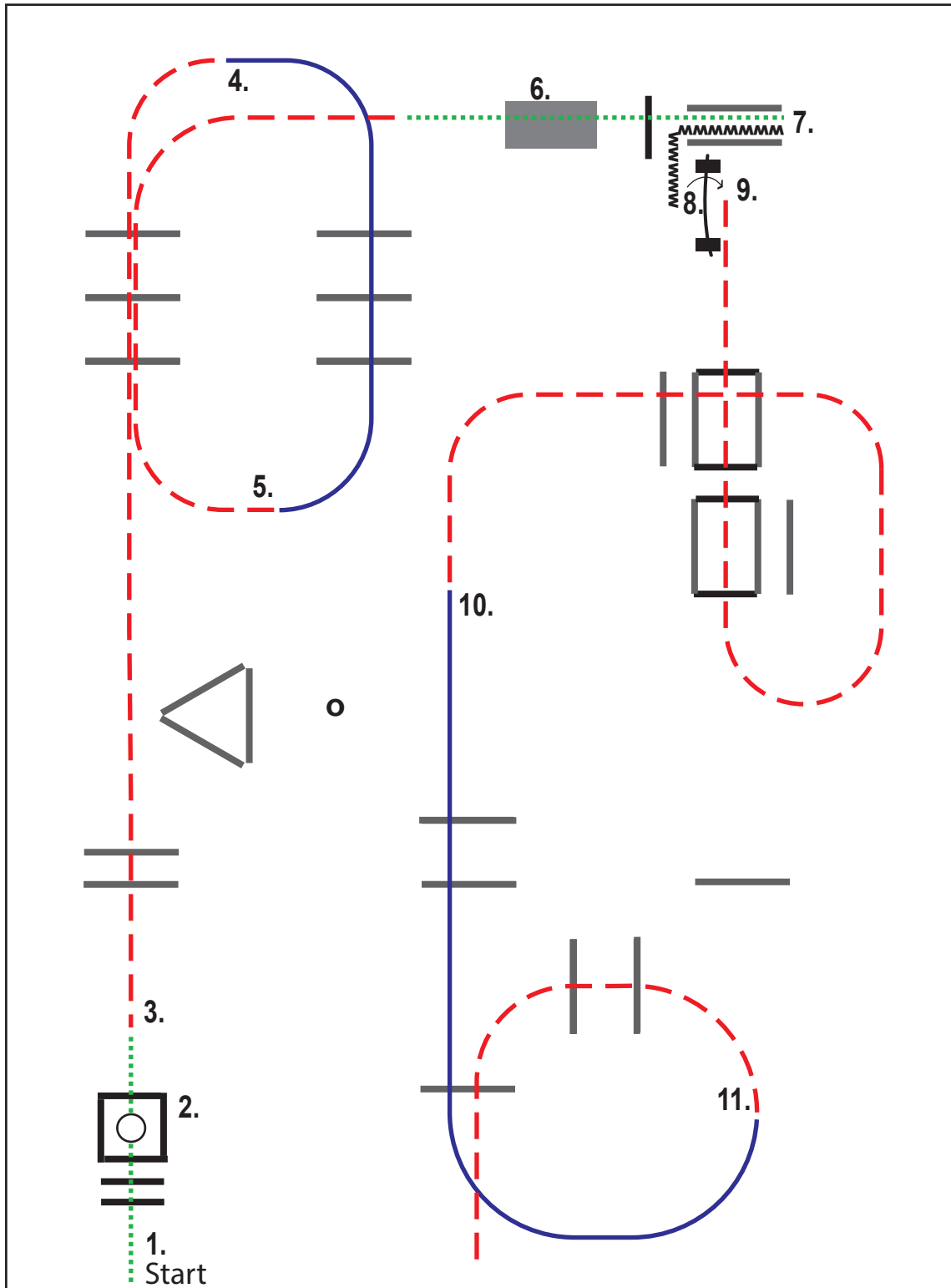

- | | |
|---|-------------------------------|
| 1. walk over poles | 7. back up to gate |
| 2. walk into box, 1 turn either way, walk out | 8. gate right hand |
| 3. jog over poles | 9. jog over poles |
| 4. lope over poles right lead | 10. lope over poles left lead |
| 5. jog over poles | 11. jog over poles |
| 6. walk over bridge and pole into chute | |

- | | |
|---------------|--------------|
| Schritt | ↔ Seitwärts |
| - - - - Trab | ○ Pylonen |
| — Galopp | X Erhöhungen |
| MMM Rückwärts | ⌋ Tor |



designed by Nina Zwölfer

CWN-C ZNS & NRHA Show/AWA Championship/B LM/WTC Cup
 Wr. Neustadt/NÖ * 03.08. - 06.08.2023
 002 Trail Open Junior

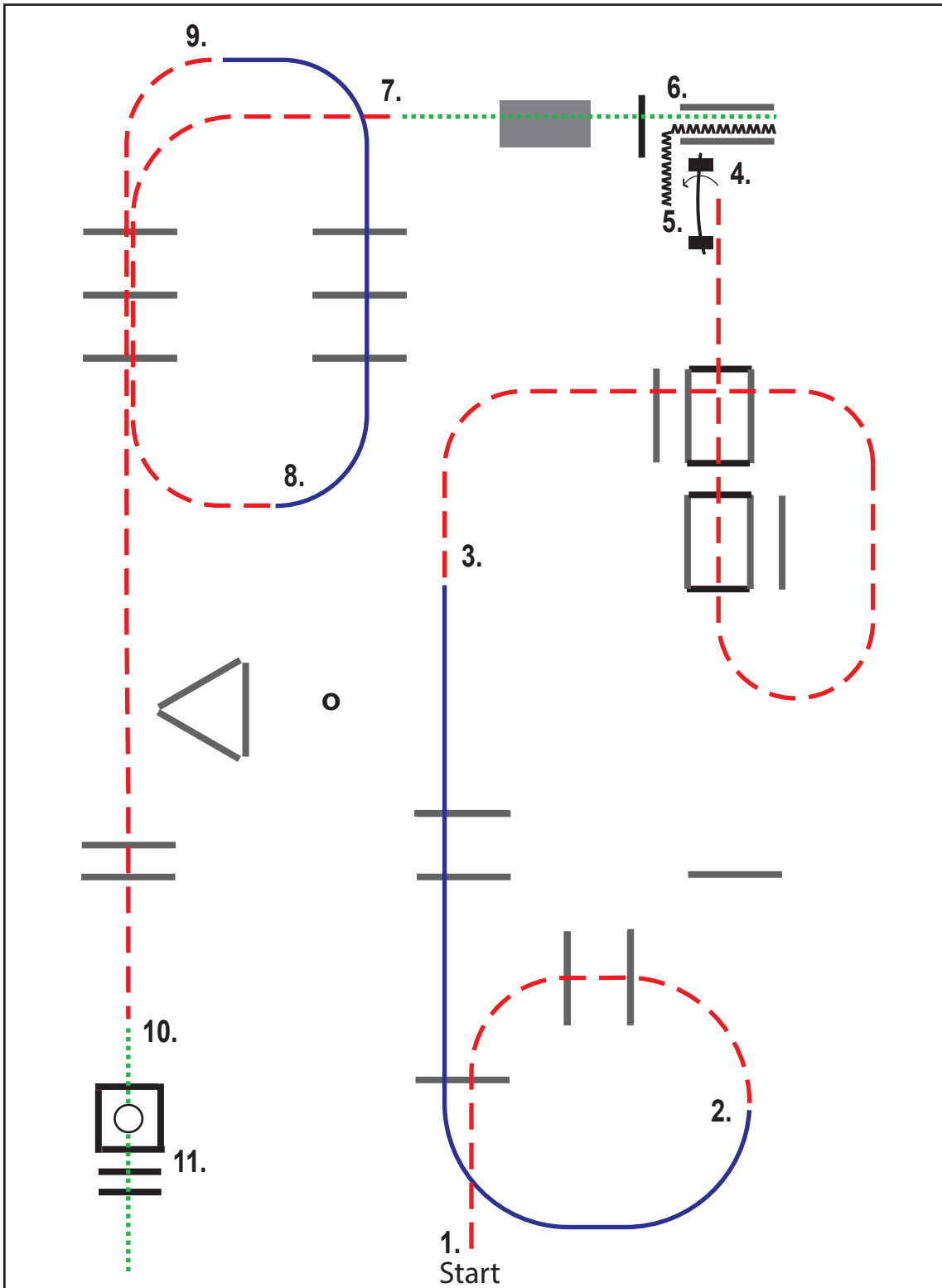

- | | |
|-------------------------------|--|
| 1. jog over poles | 7. jog over poles |
| 2. lope over poles right lead | 8. lope over poles left lead |
| 3. jog over poles to gate | 9. jog over poles |
| 4. gate left hand | 10. walk into box, 1 turn either way, walk out |
| 5. back up | 11. walk over poles |
| 6. walk over pole and bridge | |

Schritt	Seitwärts
Trab	Pylonen
Galopp	Erhöhungen
Rückwärts	Tor



designed by Nina Zwölfer

CWN-C ZNS & NRHA Show/AWA Championship/B LM/WTC Cup
 Wr. Neustadt/NÖ * 03.08. - 06.08.2023
 003 Trail Open PT Vorlauf & 004 Trail Amateur Vorlauf

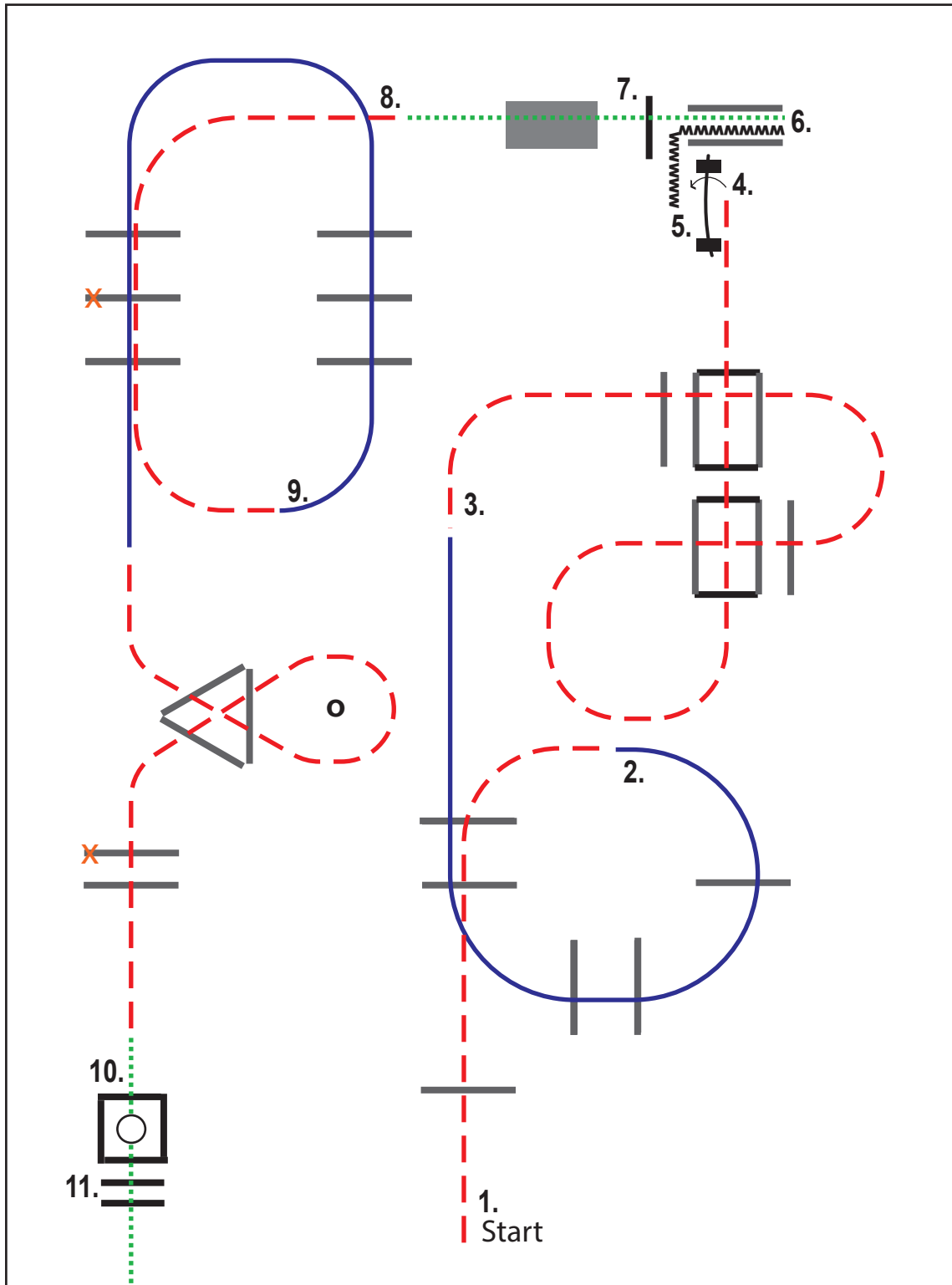

- | | |
|-------------------------------|---|
| 1. jog over poles | 7. jog over poles |
| 2. lope over poles right lead | 8. lope over poles left lead |
| 3. jog over poles | 9. jog over poles |
| 4. gate left hand | 10. walk into box, 2 turns either way, walk out |
| 5. back up | 11. walk over poles |
| 6. walk over pole and bridge | |

- | | |
|----------------|--------------|
| Schritt | ↔ Seitwärts |
| - - - - - Trab | ○ Pylonen |
| ———— Galopp | X Erhöhungen |
| MMM Rückwärts | ⌂ Tor |



designed by Nina Zwölfer

CWN-C ZNS & NRHA Show/AWA Championship/B LM/WTC Cup
 Wr. Neustadt/NÖ * 03.08. - 06.08.2023
 005 Trail Open Senior & 006 Trail Open Vorlauf

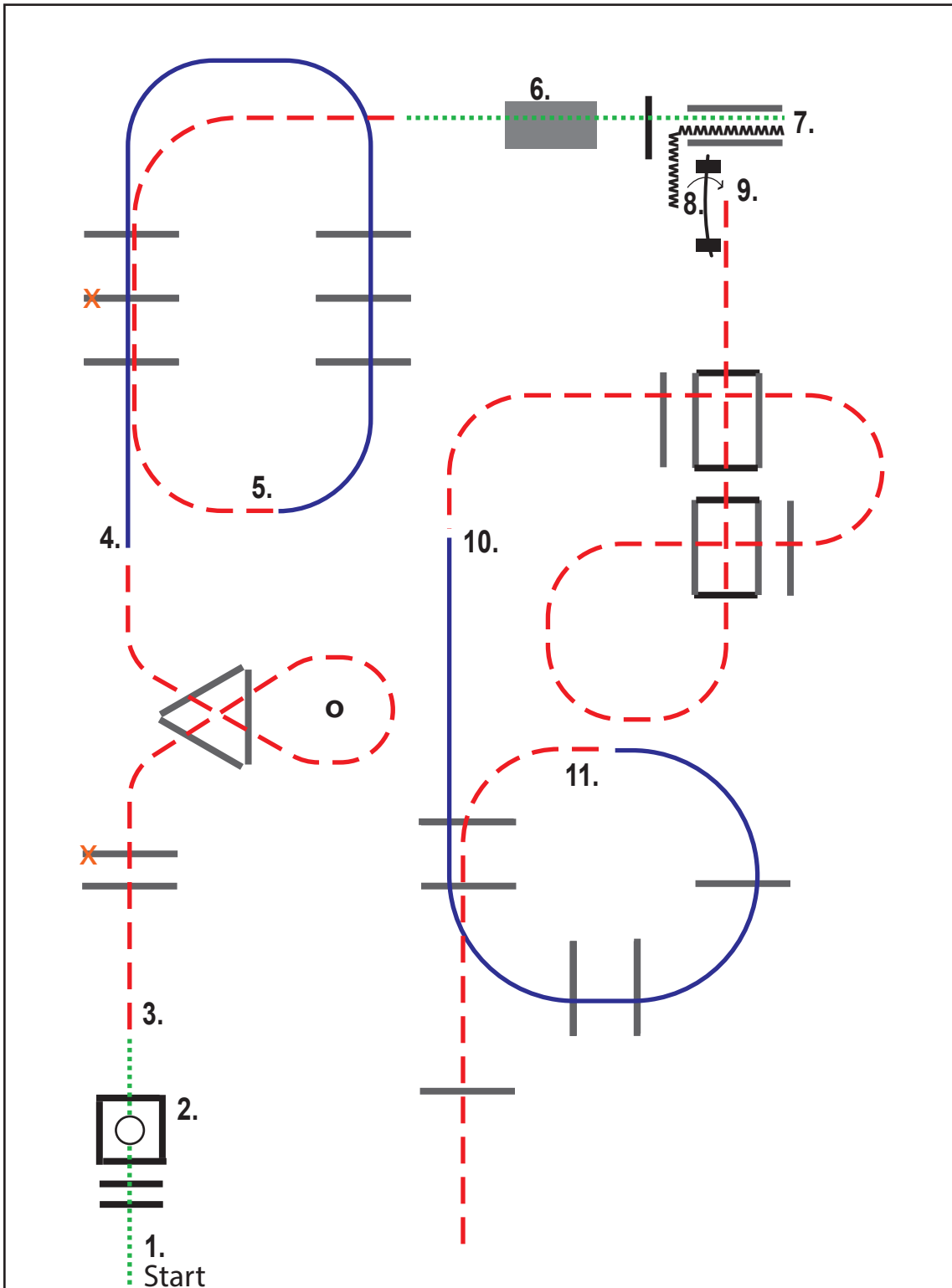

- | | |
|---|-------------------------------|
| 1. walk over poles | 7. back up |
| 2. 2 turns either way, walk out | 8. gate right hand |
| 3. jog over poles | 9. jog over poles |
| 4. lope over poles right lead | 10. lope over poles left lead |
| 5. jog over poles | 11. jog over poles |
| 6. walk over bridge and pole into chute | |

- | | |
|----------------|--------------|
| Schritt | ↔ Seitwärts |
| - - - - - Trab | ○ Pylonen |
| ———— Galopp | X Erhöhungen |
| MMM Rückwärts | ⊢ Tor |



designed by Nina Zwölfer

CWN-C ZNS & NRHA Show/AWA Championship/B LM/WTC Cup
 Wr. Neustadt/NÖ * 03.08. - 06.08.2023
 025 Trail Amateur Finale

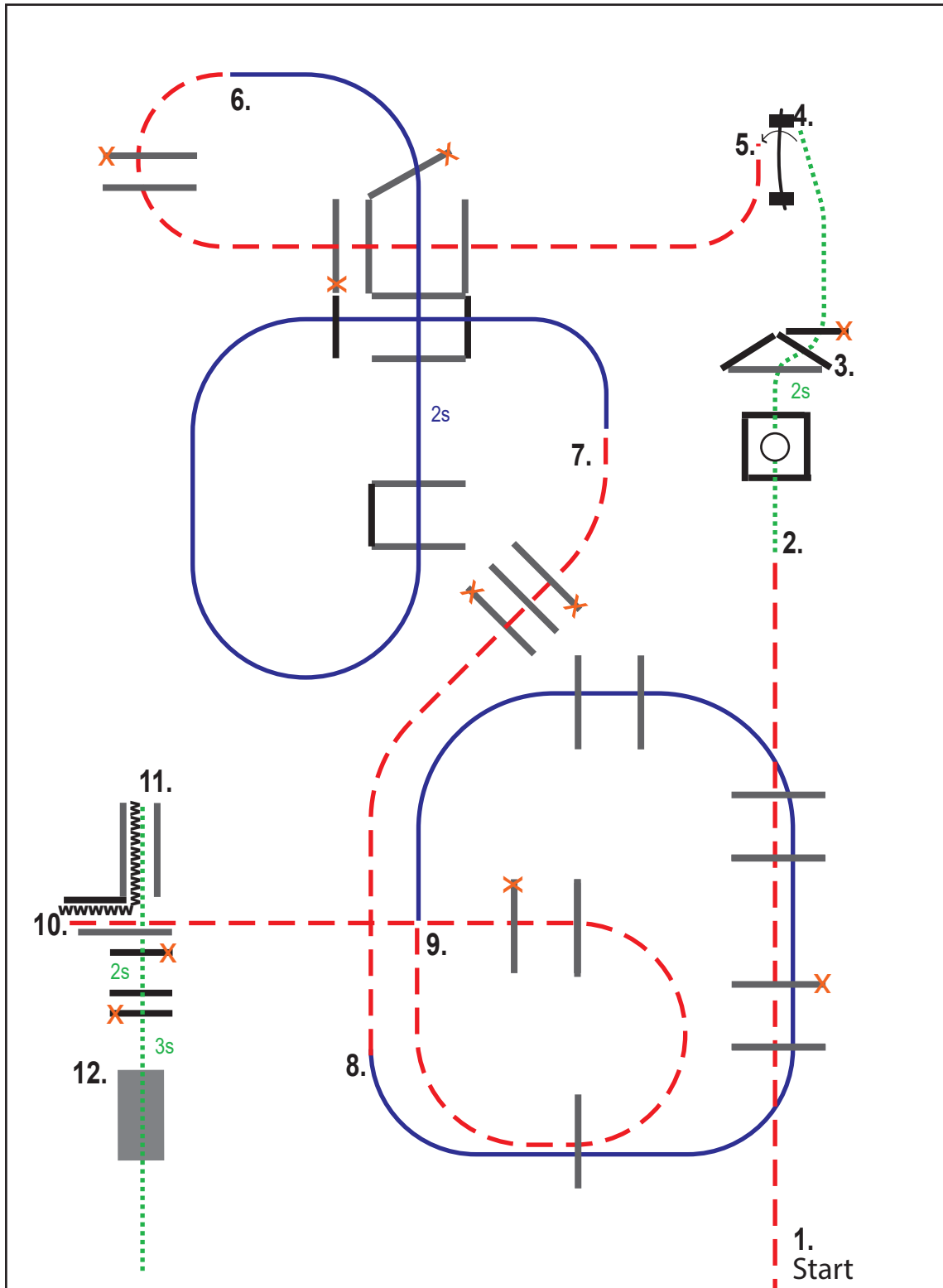

- 1. jog over poles
- 2. walk into box, 2 turns either way, walk out
- 3. walk over poles to gate
- 4. gate left hand
- 5. jog over poles
- 6. lope over poles right lead

- 7. jog over poles
- 8. lope over poles left lead
- 9. jog over poles into chute
- 10. back up „L“
- 11. walk over poles
- 12. walk over bridge

- Schritt
- Trab
- Galopp
- MMM** Rückwärts
- Seitwärts
- Pylonen
- X** Erhöhungen
- Tor



designed by Nina Zwölfer

CWN-C ZNS & NRHA Show/AWA Championship/B LM/WTC Cup
 Wr. Neustadt/NÖ * 03.08. - 06.08.2023
 026 Trail Open PrimeTime Finale

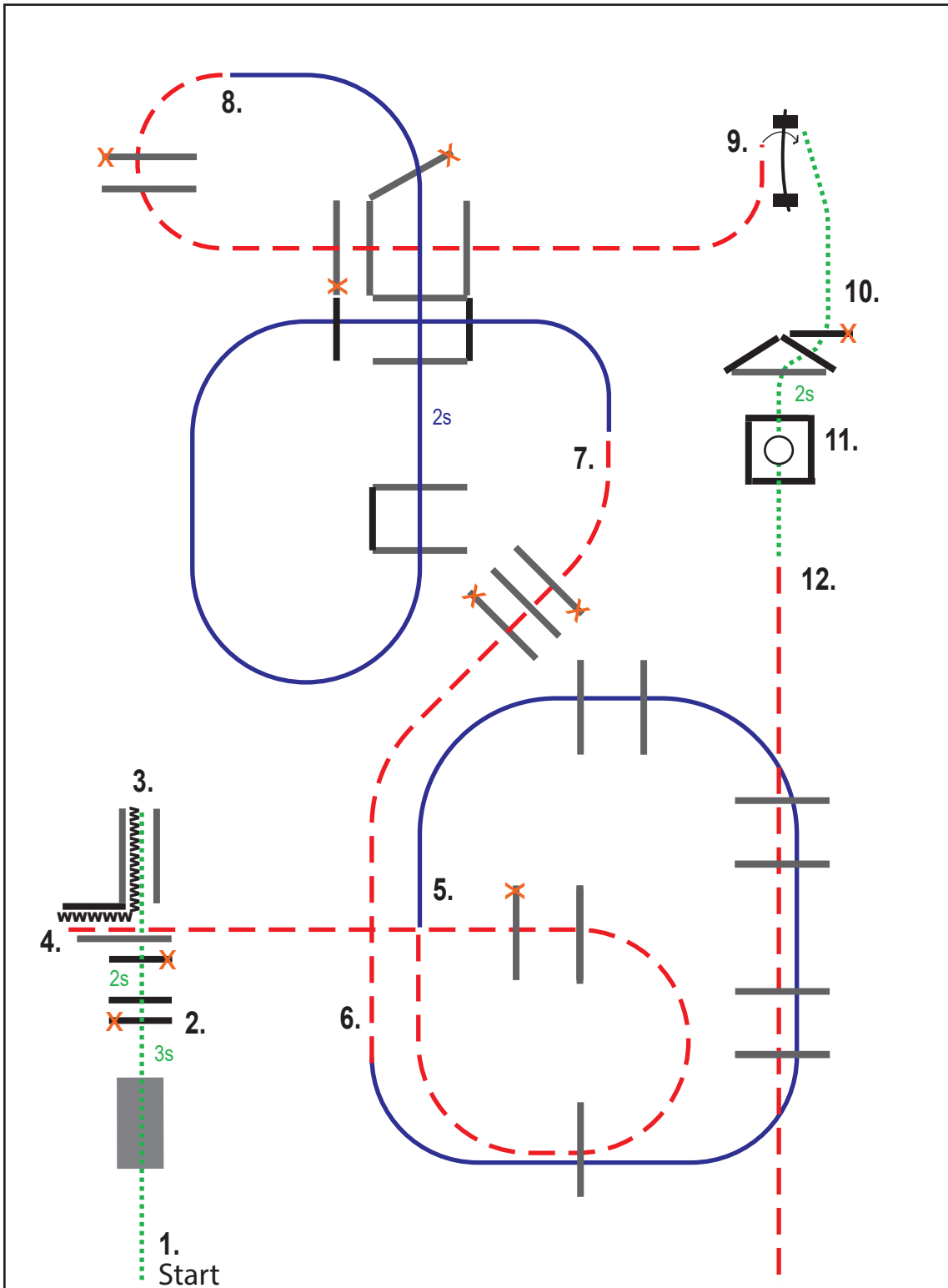

- | | |
|-------------------------------|---------------------------------|
| 1. walk over bridge | 7. lope over poles left lead |
| 2. walk over poles | 8. jog over poles to gate |
| 3. back up „L“ | 9. gate right hand |
| 4. jog over poles | 10. walk over poles |
| 5. lope over poles right lead | 11. 1 turn either way, walk out |
| 6. jog over poles | 12. jog over poles |

Schritt	Seitwärts
Trab	Pylonen
Galopp	Erhöhungen
Rückwärts	Tor



designed by Nina Zwölfer

CWN-C ZNS & NRHA Show/AWA Championship/B LM/WTC Cup
 Wr. Neustadt/NÖ * 03.08. - 06.08.2023
 027 Trail Novice Amateur

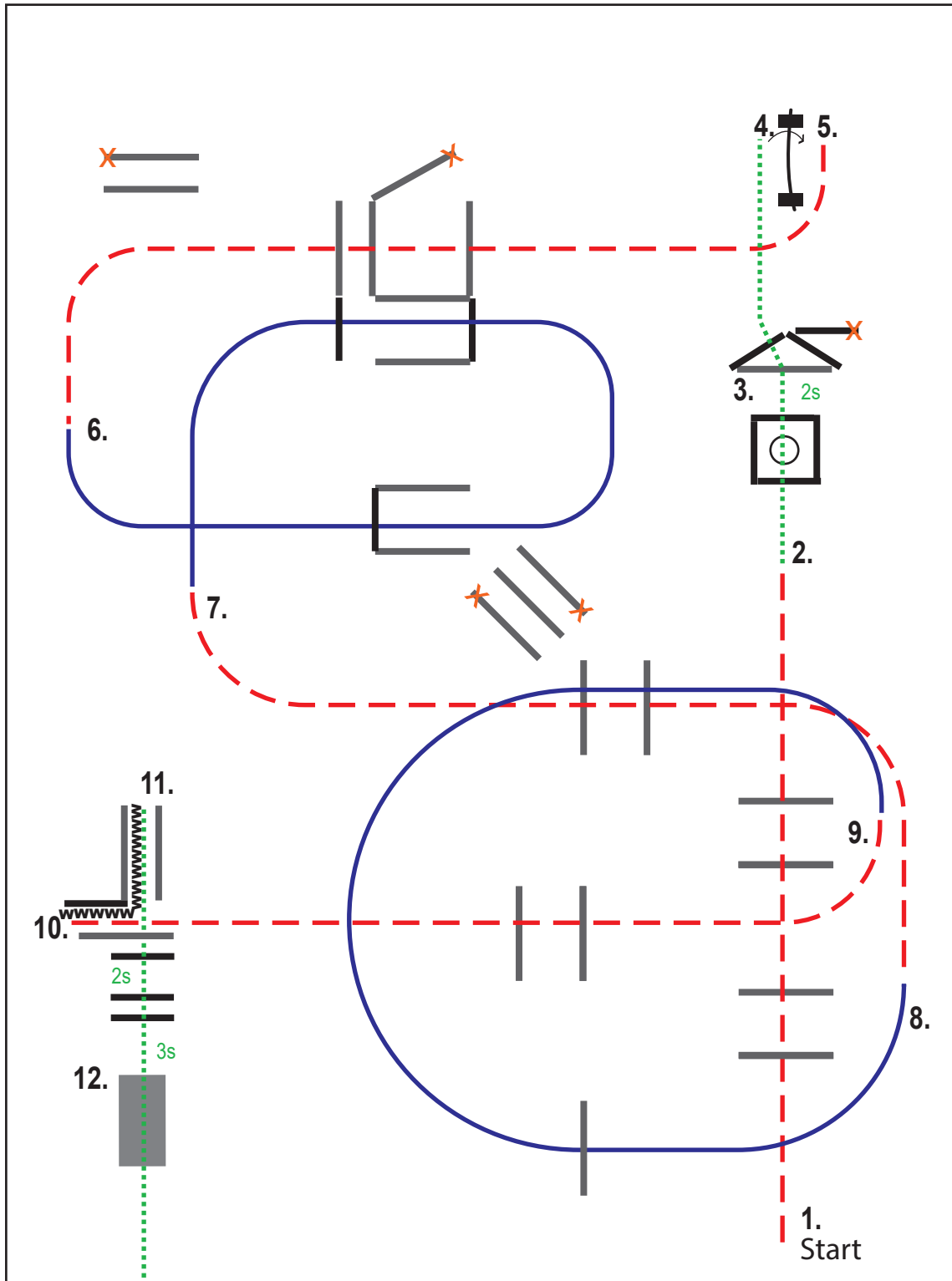

- | | |
|---|-------------------------------|
| 1. jog over poles | 7. jog over poles |
| 2. walk into box, 1 turn either way, walk out | 8. lope over poles right lead |
| 3. walk over poles to gate | 9. jog over poles into chute |
| 4. gate right hand | 10. back up „L“ |
| 5. jog over poles | 11. walk over poles |
| 6. lope over poles left lead | 12. walk over bridge |

- | | |
|----------------|--------------|
| Schritt | ↔ Seitwärts |
| - - - - - Trab | ○ Pylonen |
| — Galopp | X Erhöhungen |
| MMM Rückwärts | ⊢ Tor |



designed by Nina Zwölfer

CWN-C ZNS & NRHA Show/AWA Championship/B LM/WTC Cup
 Wr. Neustadt/NÖ * 03.08. - 06.08.2023
 028 Trail Youngster & 029 Trail Youngster

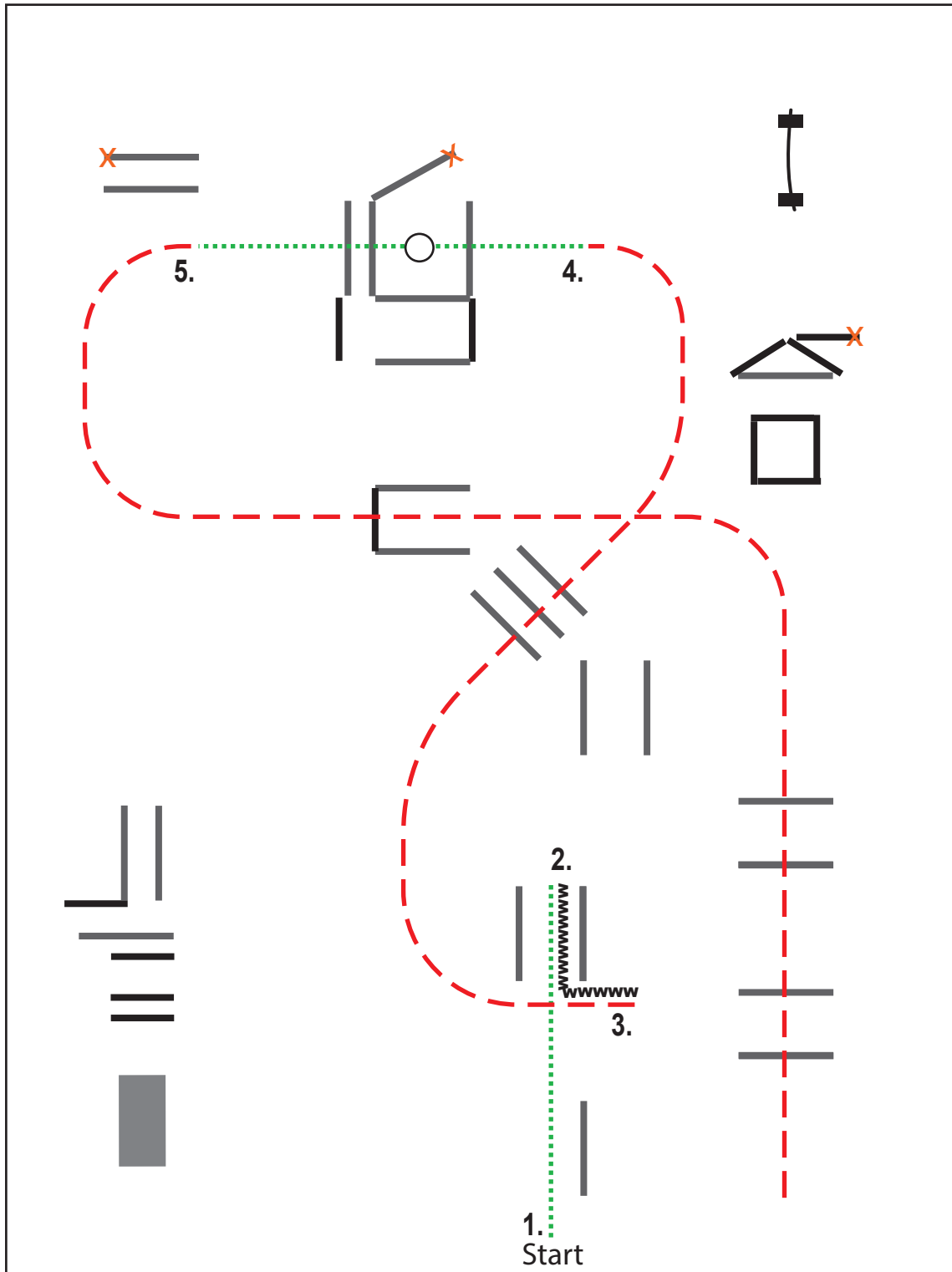

1. walk into chute
2. back up „L“
3. jog over poles
4. walk into box, turn 360° right, walk out
5. jog over poles

- | | |
|----------------|--------------|
| Schritt | ↔ Seitwärts |
| - - - - - Trab | ○ Pylonen |
| — Galopp | X Erhöhungen |
| MMM Rückwärts | ⊥ Tor |



designed by Nina Zwölfer

CWN-C ZNS & NRHA Show/AWA Championship/B LM/WTC Cup
 Wr. Neustadt/NÖ * 03.08. - 06.08.2023
 053 Trail Youth

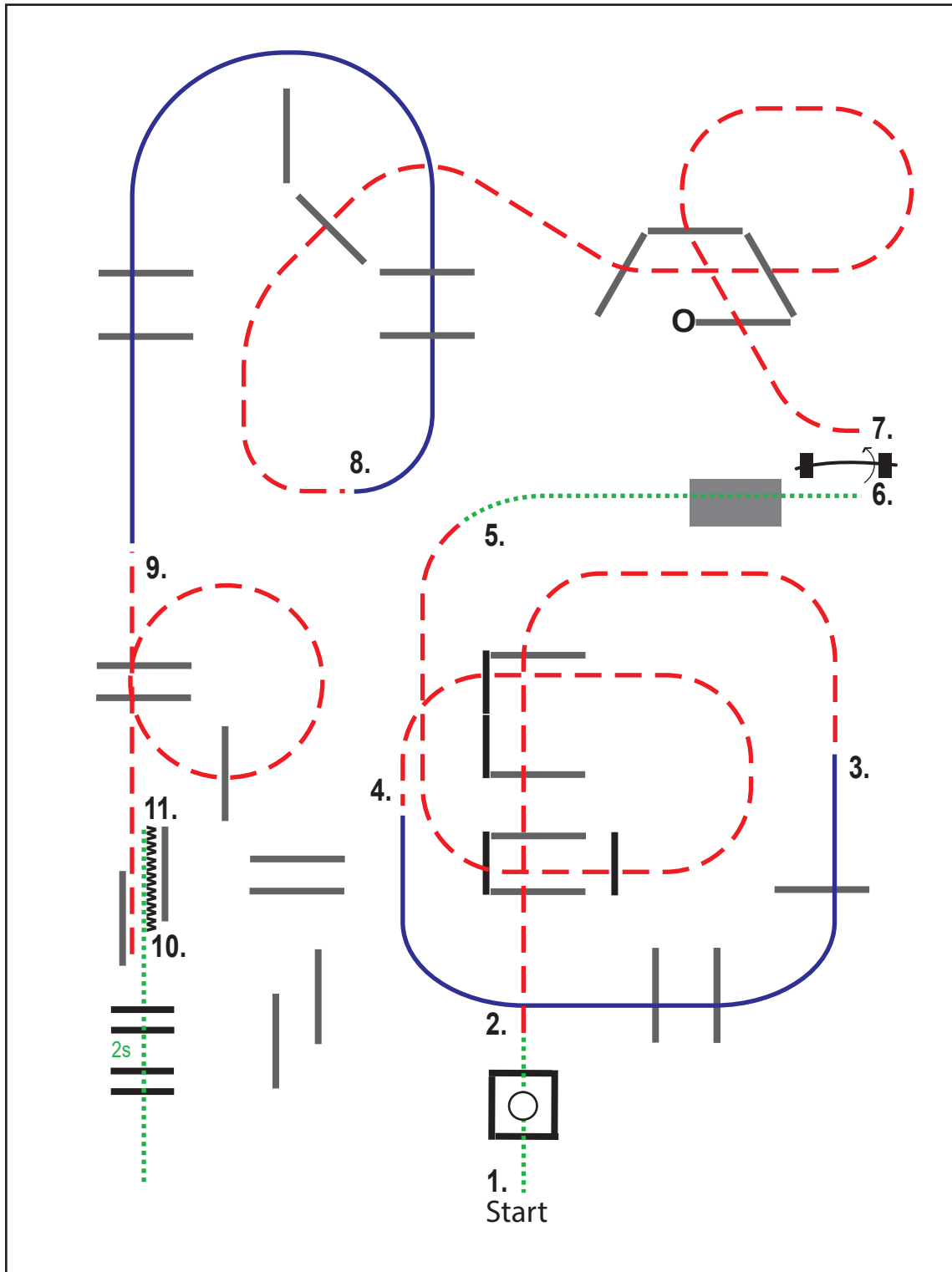

- | | |
|-------------------------------------|------------------------------|
| 1. walk into box, 1 turn either way | 7. jog over poles |
| 2. jog over poles | 8. lope over poles left lead |
| 3. lope over poles right lead | 9. jog over poles into chute |
| 4. jog over poles | 10. backup |
| 5. walk over bridge | 11. walk over poles |
| 6. gate left hand | |

- | | |
|---------------|--------------|
| Schritt | ↔ Seitwärts |
| - - - - Trab | ○ Pylonen |
| ———— Galopp | X Erhöhungen |
| MMM Rückwärts | ⊢ Tor |



designed by Nina Zwölfer

CWN-C ZNS & NRHA Show/AWA Championship/B LM/WTC Cup
 Wr. Neustadt/NÖ * 03.08. - 06.08.2023
 054 Trail Novice Amateur Finale

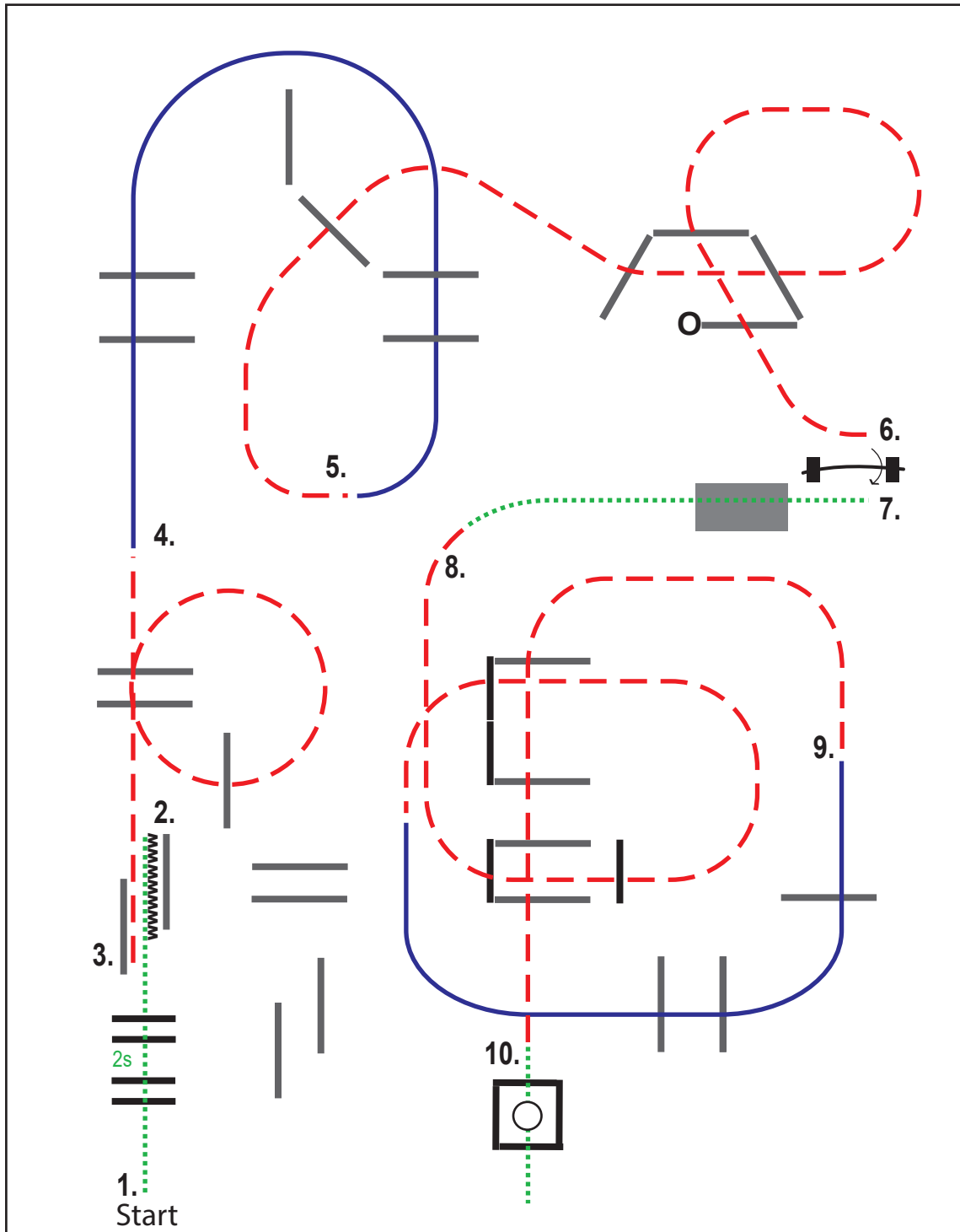

- 1. walk over poles
- 2. backup
- 3. jog over poles
- 4. lope over poles right lead
- 5. jog over poles to gate
- 6. gate right hand

- 7. walk over bridge
- 8. jog over poles
- 9. lope over poles left lead
- 10. jog over poles
- 11. walk into box, 1 turn either way, walk out

..... Schritt

- - - - - Trab

———— Galopp

MMM Rückwärts

↔ Seitwärts

○ Pylonen

X Erhöhungen

⌢ Tor



designed by Nina Zwölfer

CWN-C ZNS & NRHA Show/AWA Championship/B LM/WTC Cup
 Wr. Neustadt/NÖ * 03.08. - 06.08.2023
 055 Trail Open & 056 Trail Open Vorlauf B LM

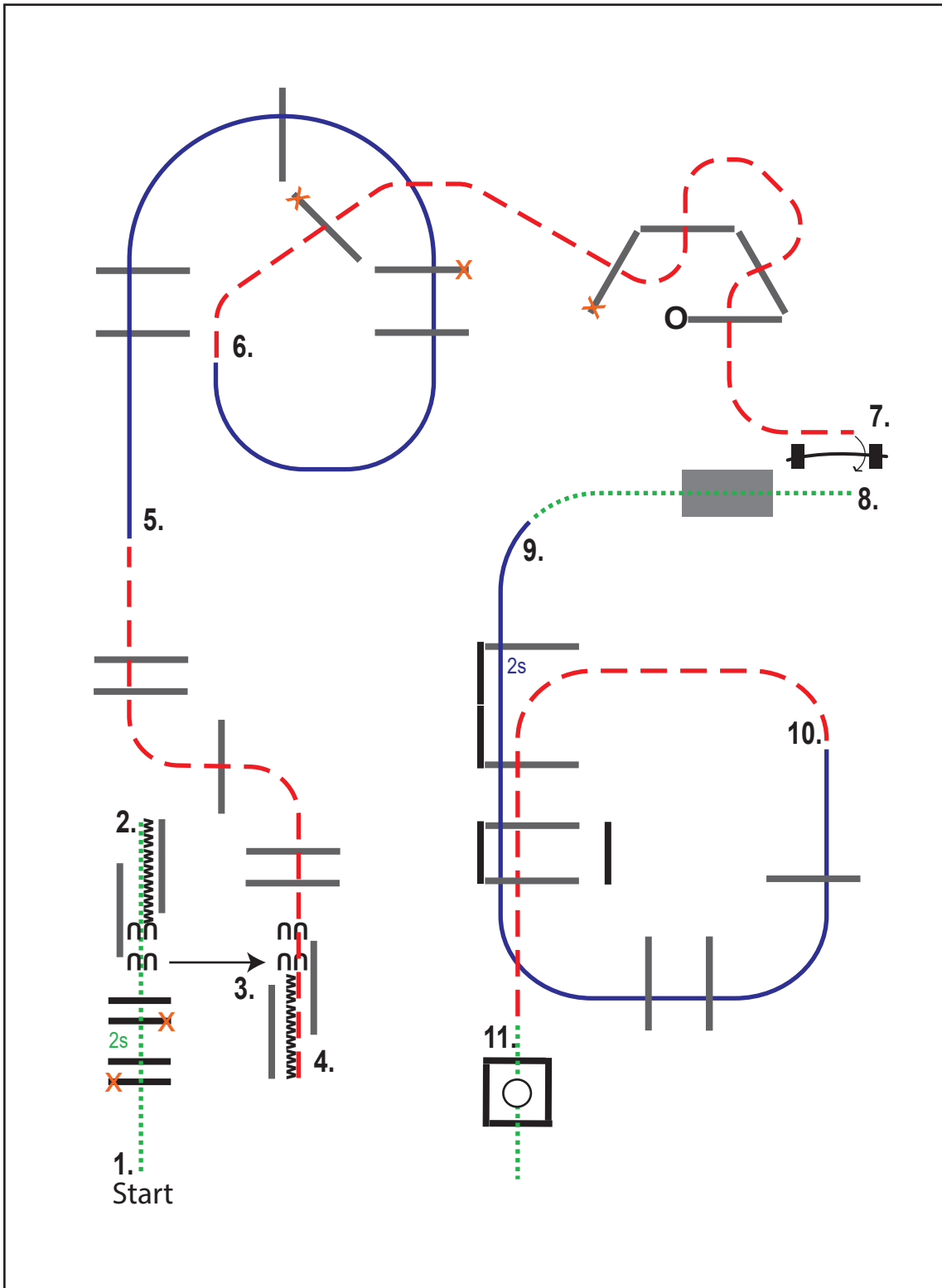

- | | |
|-------------------------------|---|
| 1. walk over poles | 7. gate right hand |
| 2. backup | 8. walk over bridge |
| 3. sidepass right, backup | 9. lope over poles left lead |
| 4. jog over poles | 10. jog over poles |
| 5. lope over poles right lead | 11. walk into box, 2 turns either way, walk out |
| 6. jog over poles to gate | |

Schritt	Seitwärts
Trab	Pylonen
Galopp	Erhöhungen
Rückwärts	Tor



designed by Nina Zwölfer

CWN-C ZNS & NRHA Show/AWA Championship/B LM/WTC Cup
 Wr. Neustadt/NÖ * 03.08. - 06.08.2023
 082 Trail Youth

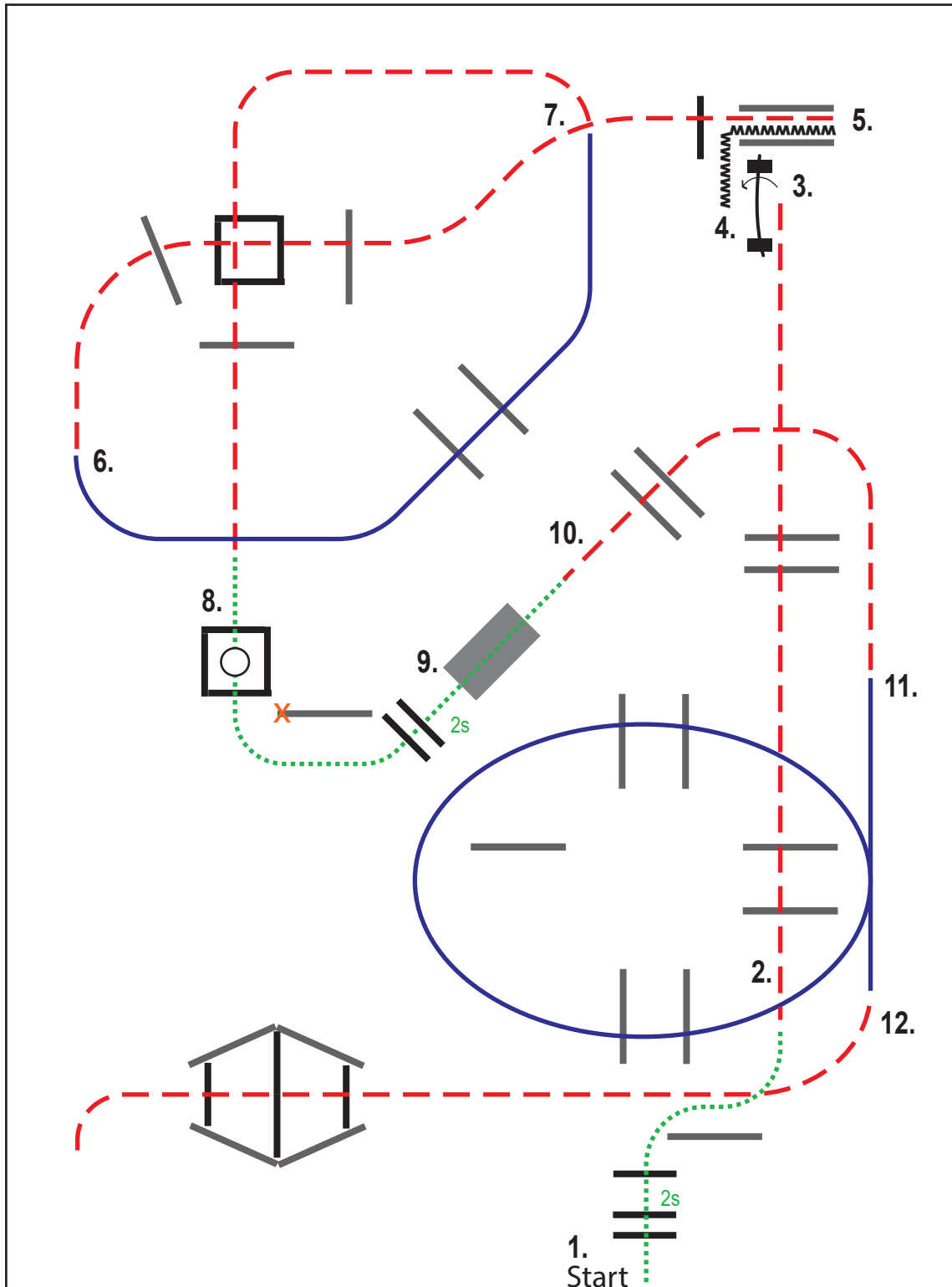

- | | |
|------------------------------|---|
| 1. walk over poles | 7. jog over poles |
| 2. jog over poles to gate | 8. walk into box, 1 turn either way, walk out |
| 3. gate left hand | 9. walk over poles and bridge |
| 4. back up | 10. jog over poles |
| 5. jog over poles | 11. lope over poles right lead |
| 6. lope over poles left lead | 12. jog over poles |

- | | |
|---------------|--------------|
| Schritt | ↔ Seitwärts |
| - - - - Trab | ○ Pylonen |
| ———— Galopp | X Erhöhungen |
| MMM Rückwärts | ⊢ Tor |



designed by Nina Zwölfer

CWN-C ZNS & NRHA Show/AWA Championship/B LM/WTC Cup
 Wr. Neustadt/NÖ * 03.08. - 06.08.2023
 083 Trail Rookie Open Finale

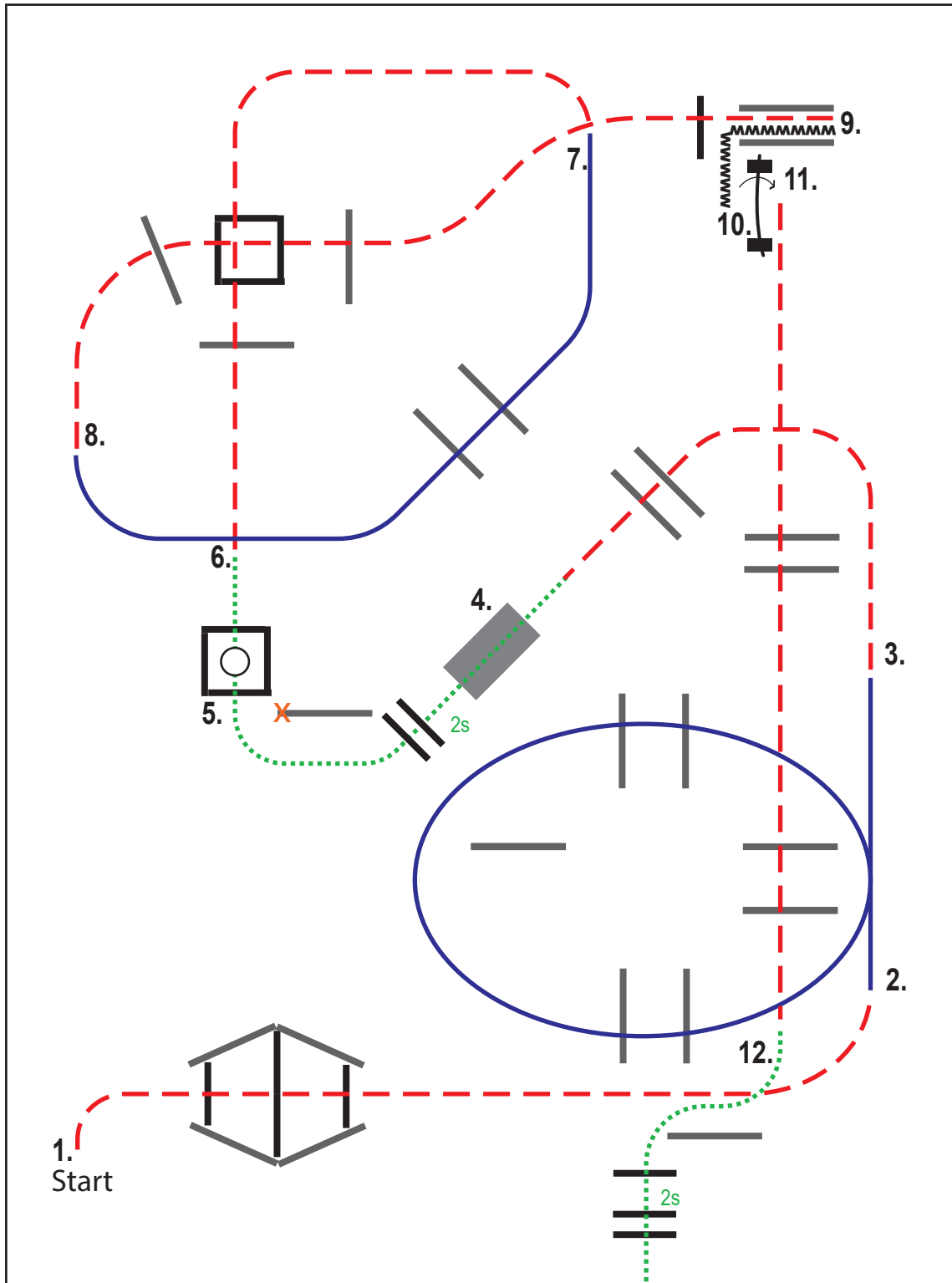

- | | |
|--|-------------------------------|
| 1. jog over poles | 7. lope over poles right lead |
| 2. lope over poles left lead | 8. jog over poles into chute |
| 3. jog over poles | 9. back up to gate |
| 4. walk over bridge and poles | 10. gate right hand |
| 5. walk into box, 1 turn either way, cwalk out | 11. jog over poles |
| 6. jog over poles | 12. walk over poles |

- | | | | |
|-----------|---------|------------|-----------|
| Schritt | Trab | Galopp | Seitwärts |
| Rückwärts | Pylonen | Erhöhungen | Tor |



designed by Nina Zwölfer

CWN-C ZNS & NRHA Show/AWA Championship/B LM/WTC Cup
 Wr. Neustadt/NÖ * 03.08. - 06.08.2023
 084 Trail Open & 085 Trail Open Finale B LM

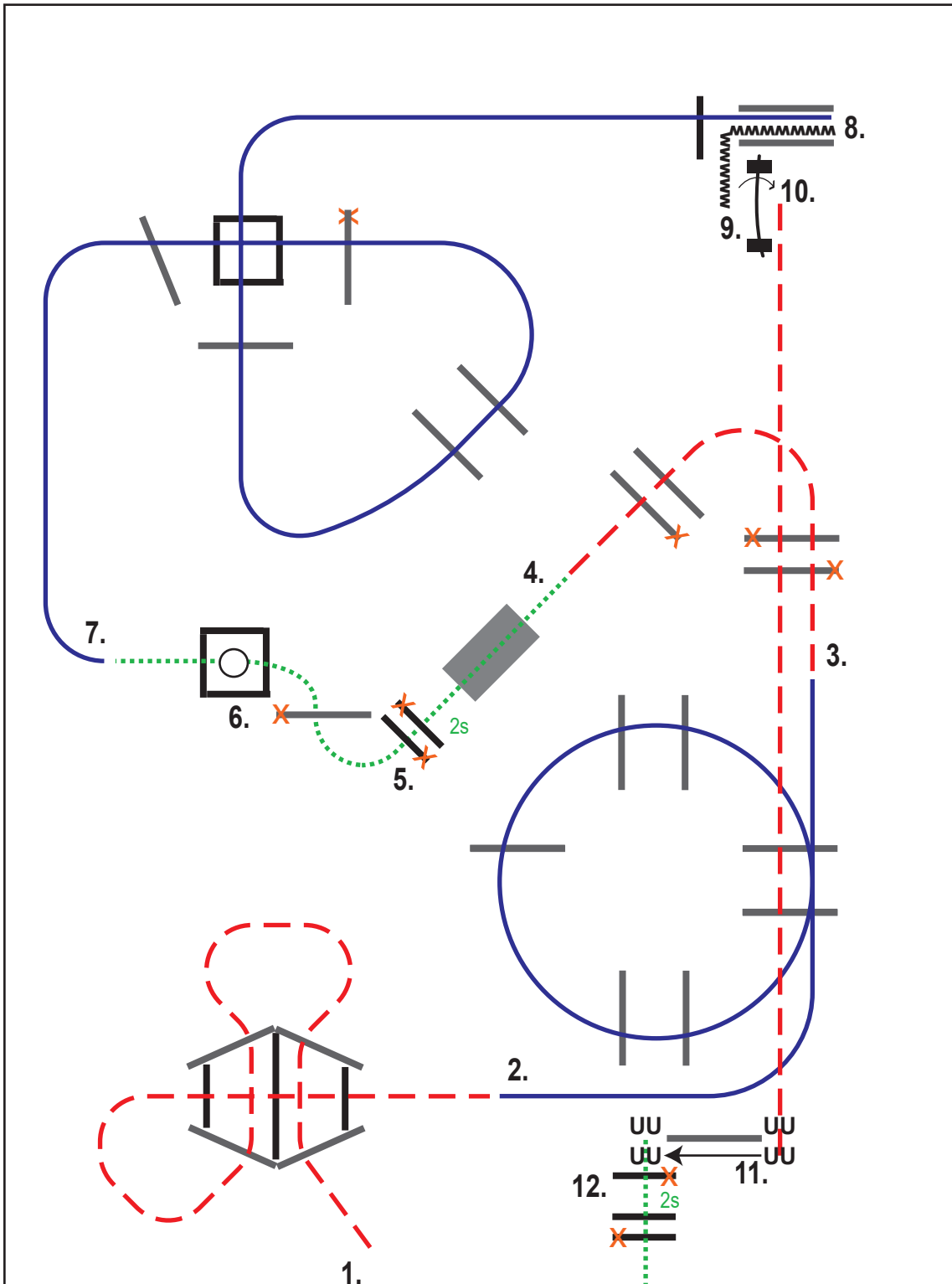

- | | |
|--------------------------------------|--|
| 1. jog over poles | 7. lope over poles right lead into chute |
| 2. lope over poles left lead | 8. back up to gate |
| 3. jog over poles | 9. gate right hand |
| 4. walk over bridge | 10. jog over poles |
| 5. walk over poles | 11. sidepass right |
| 6. walk into box, 2 turns either way | 12. walk over poles |

Schritt	Seitwärts
Trab	Pylonen
Galopp	Erhöhungen
Rückwärts	Tor



designed by Nina Zwölfer