

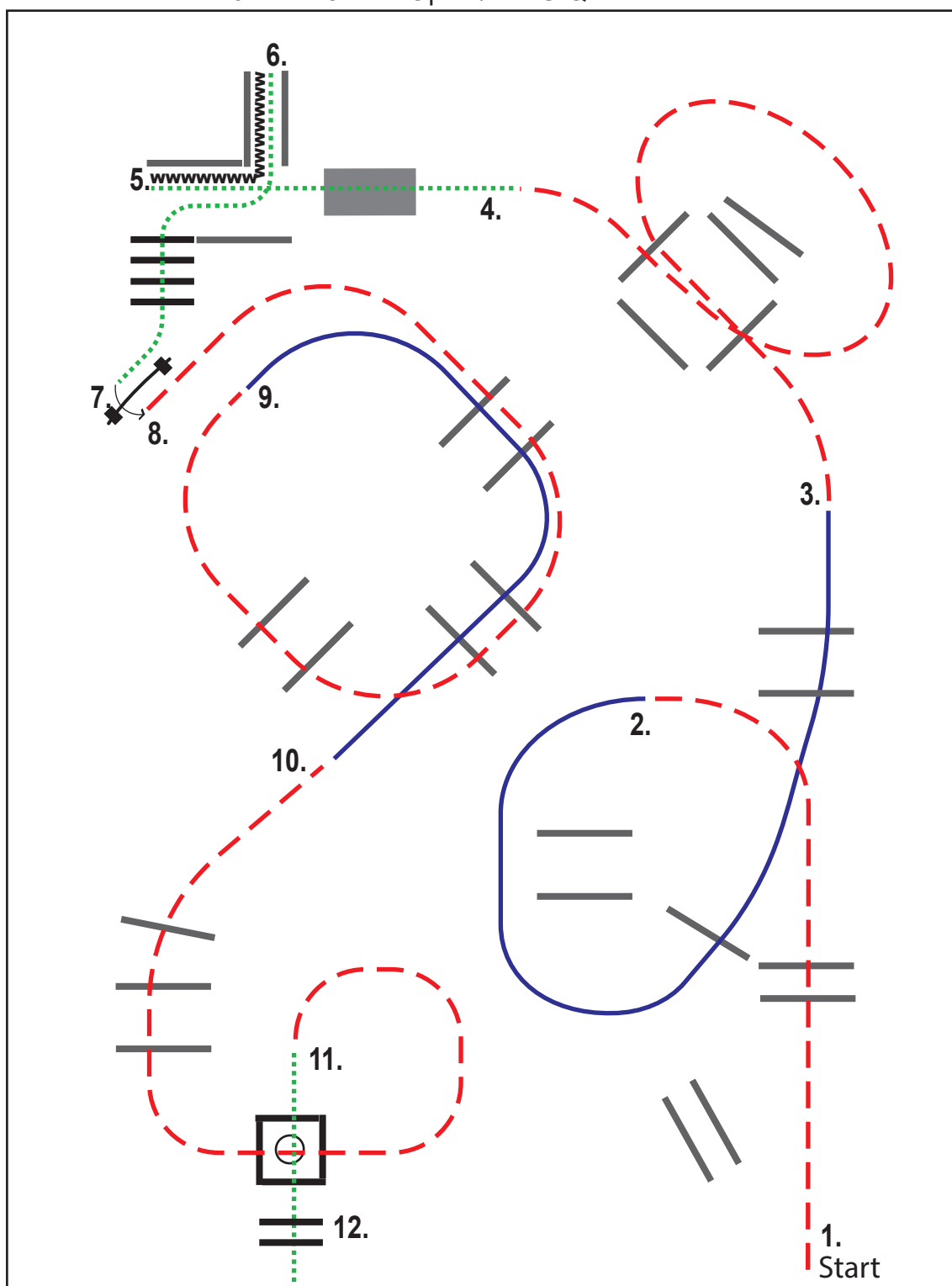

CWN-C ZNS / WTC Cup / BLMM / Senior Master / ARHA Challenge  
 Wr. Neustadt/NÖ \* 18.05. - 20.05.2024  
 02 Trail Junior Open / EWU Qualifikation



- |                              |   |
|------------------------------|---|
| 1. jog over poles            | 7. gate left hand                       |
| 2. lope over poles left lead | 8. jog over poles                       |
| 3. jog over poles            | 9. lope over poles right lead           |
| 4. walk over bridge          | 10. jog over poles                      |
| 5. back up                   | 11. walk into box, turn 360° either way |
| 6. walk over poles to gate   | 12. walk over poles                     |

- |                |              |
|----------------|--------------|
| ..... Schritt  | ↔ Seitwärts  |
| - - - - - Trab | ○ Pylonen    |
| ———— Galopp    | X Erhöhungen |
| MMM Rückwärts  | ⊢ Tor        |



designed by Nina Zwölfer

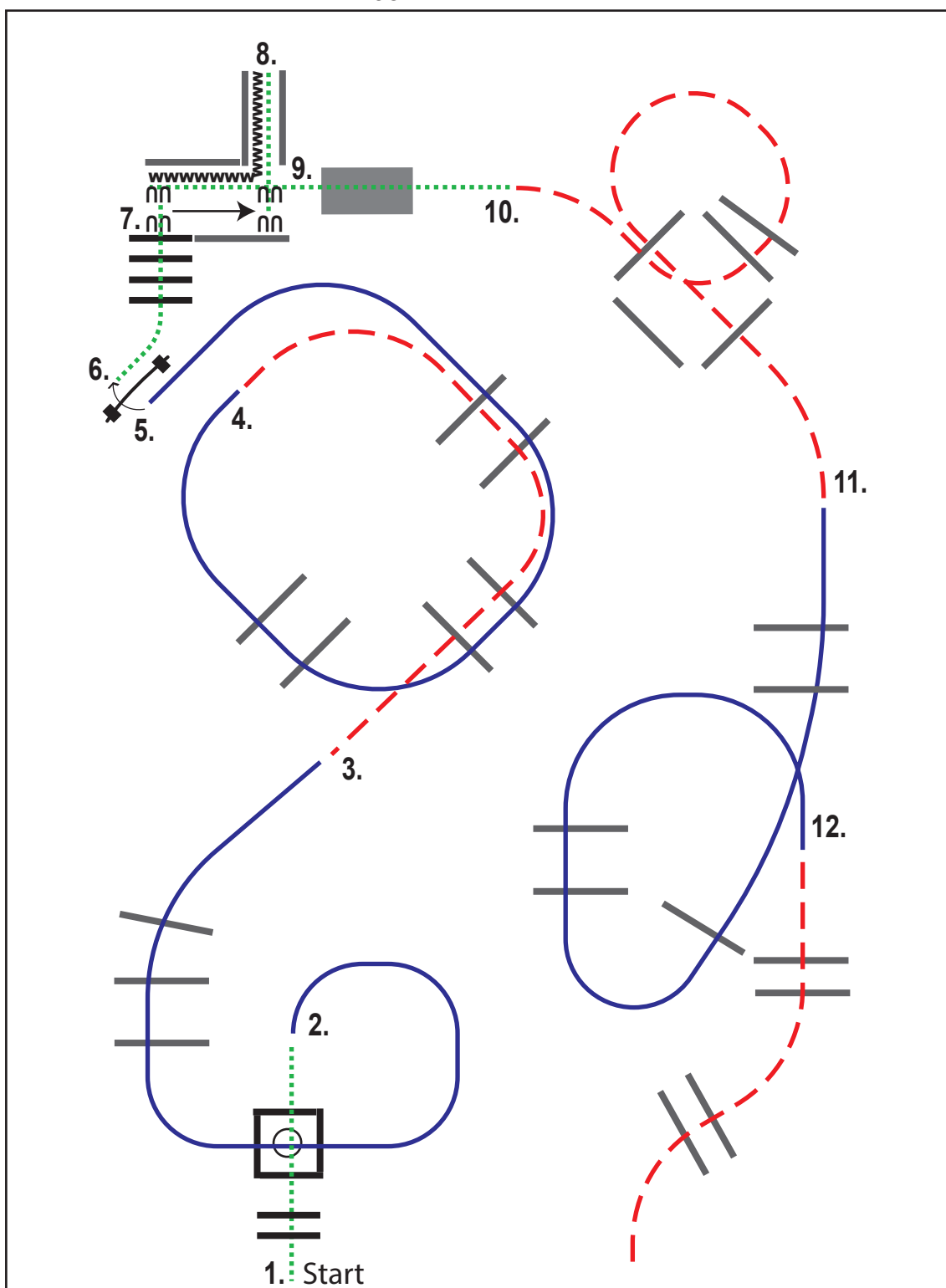

1. walk over poles into box, turn 720° either way
2. lope over poles right lead
3. jog over poles
4. lope over poles left lead to gate
5. gate right hand
6. walk over poles

7. sidepass right, walk into chute
8. back up
9. walk over bridge
10. jog over poles
11. lope over poles right lead
12. jog over poles

- |           |            |
|-----------|------------|
| Schritt   | Seitwärts  |
| Trab      | Pylonen    |
| Galopp    | Erhöhungen |
| Rückwärts | Tor        |



CWN-C ZNS / WTC Cup / BLMM / Senior Master / ARHA Challenge  
 Wr. Neustadt/NÖ \* 18.05. - 20.05.2024  
 04 Trail Senior Open / EWU Qualifikation

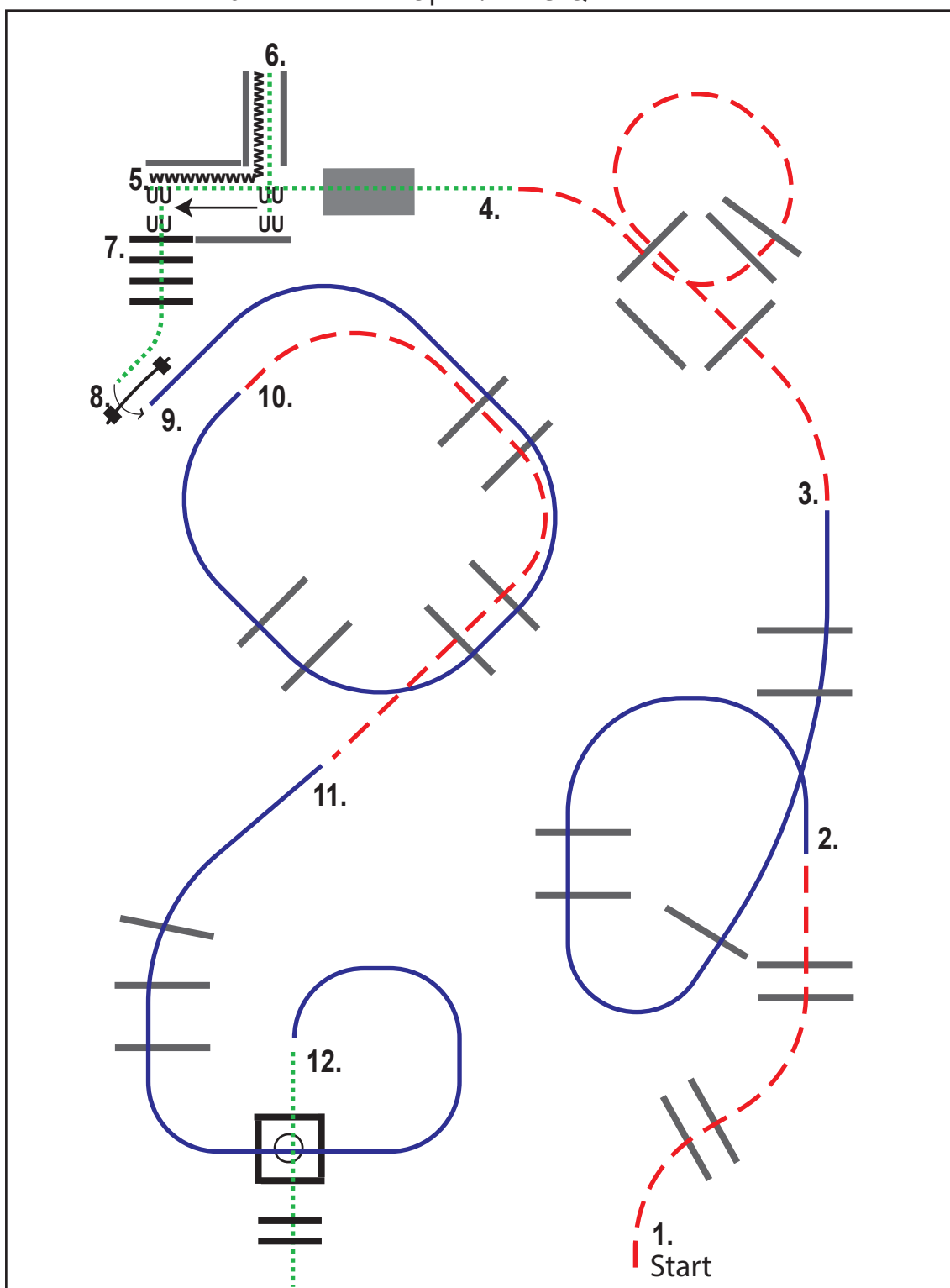

- |  |  |
|--|--|
| 1. jog over poles                              | 7. walk over poles to gate                               |
| 2. lope over poles left lead                   | 8. gate left hand  |
| 3. jog over poles                              | 9. lope over poles right lead                            |
| 4. walk over bridge                            | 10. jog over poles                                       |
| 5. back up                                     | 11. lope over poles left lead, break to walk or stop     |
| 6. walk, in front of pole stop, sidepass right | 12. walk into box, turn 720° either way, walk over poles |

- |                |              |
|----------------|--------------|
| ..... Schritt  | ↔ Seitwärts  |
| - - - - Trab   | ○ Pylonen    |
| — Galopp       | X Erhöhungen |
| MMMM Rückwärts | ⌋ Tor        |



designed by Nina Zwölfer

CWN-C ZNS / WTC Cup / BLMM / Senior Master / ARHA Challenge  
 Wr. Neustadt/NÖ \* 18.05. - 20.05.2024  
 05 Trail Novice Amateur

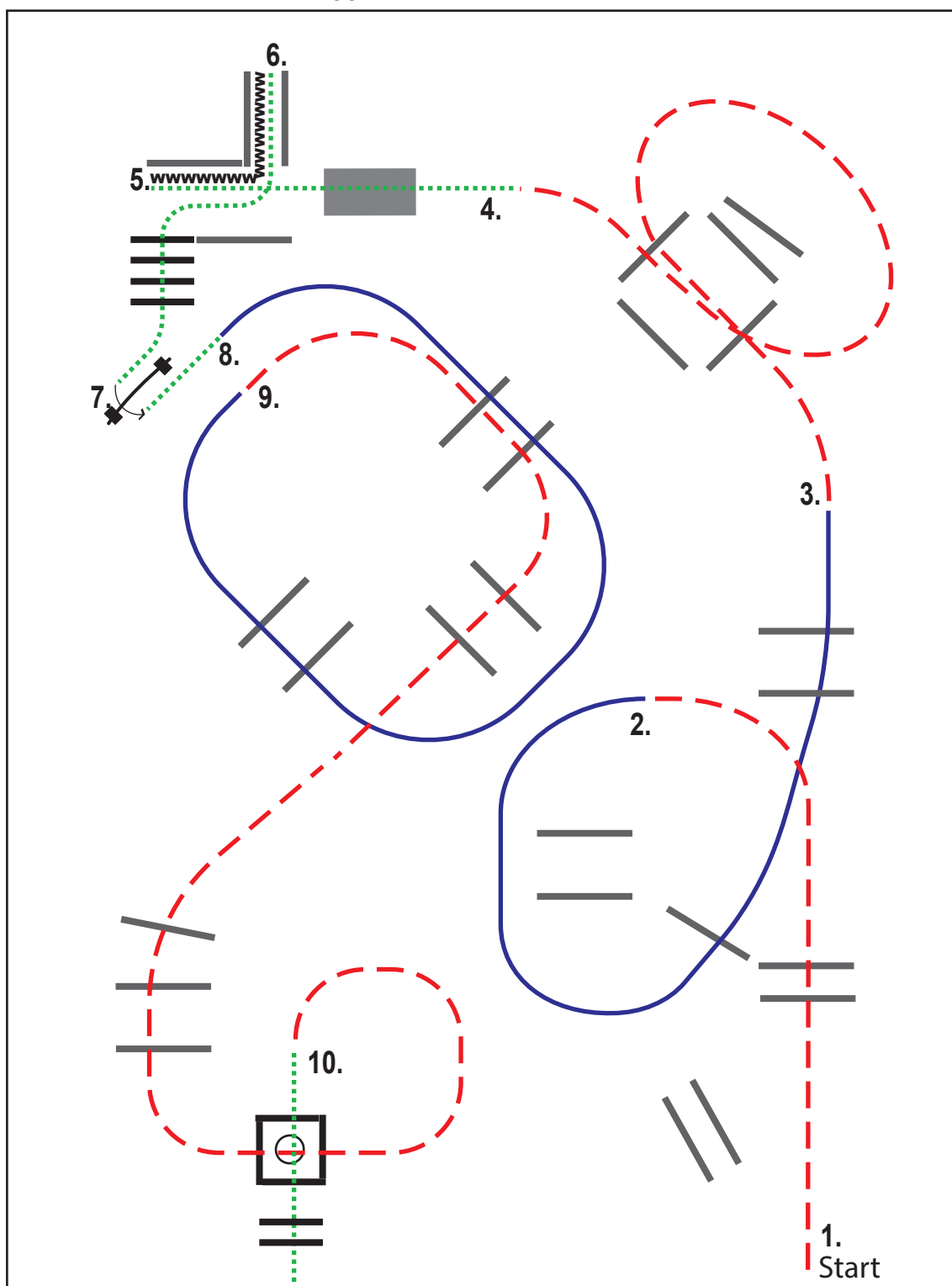

- |                              |  |
|------------------------------|--|
| 1. jog over poles            | 6. walk over poles to gate                               |
| 2. lope over poles left lead | 7. gate left hand  |
| 3. jog over poles            | 8. lope over poles right lead                            |
| 4. walk over bridge          | 9. jog over poles  |
| 5. back up                   | 10. walk into box, turn 360° either way, walk over poles |

Schritt	Seitwärts
Trab	Pylonen
Galopp	Erhöhungen
Rückwärts	Tor



designed by Nina Zwölfer

CWN-C ZNS / WTC Cup / BLMM / Senior Master / ARHA Challenge  
 Wr. Neustadt/NÖ \* 18.05. - 20.05.2024  
 30 Trail PT & 31 Trail Open Senior Master Vorlauf

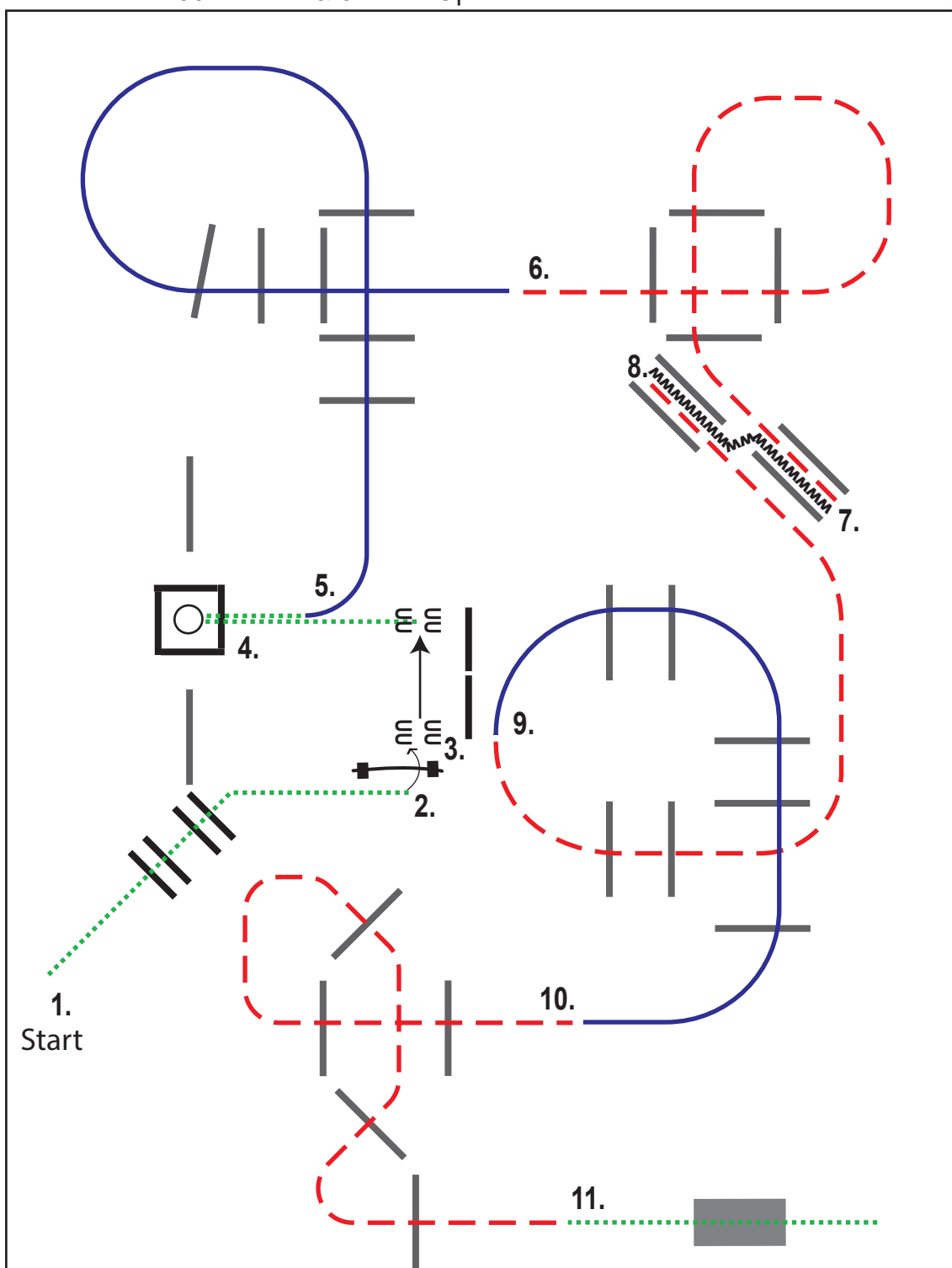

- |   |                               |
|---|-------------------------------|
| 1. walk over poles to gate                  | 6. jog over poles into chute  |
| 2. gate left hand                           | 7. back up                    |
| 3. sidepass right                           | 8. jog out and over pole      |
| 4. walk over into box, turn 540° either way | 9. lope over poles right lead |
| 5. lope over poles left lead                | 10. jog over poles            |
|   | 11. walk over bridge          |

- |                |                |
|----------------|----------------|
| ..... Schritt  | nn → Seitwärts |
| - - - - - Trab | ○ Pylonen      |
| ———— Galopp    | X Erhöhungen   |
| MMM Rückwärts  | ⊢ Tor          |



designed by Nina Zwölfer

CWN-C ZNS / WTC Cup / BLMM / Senior Master / ARHA Challenge  
 Wr. Neustadt/NÖ \* 18.05. - 20.05.2024  
 32 Trail Rookie

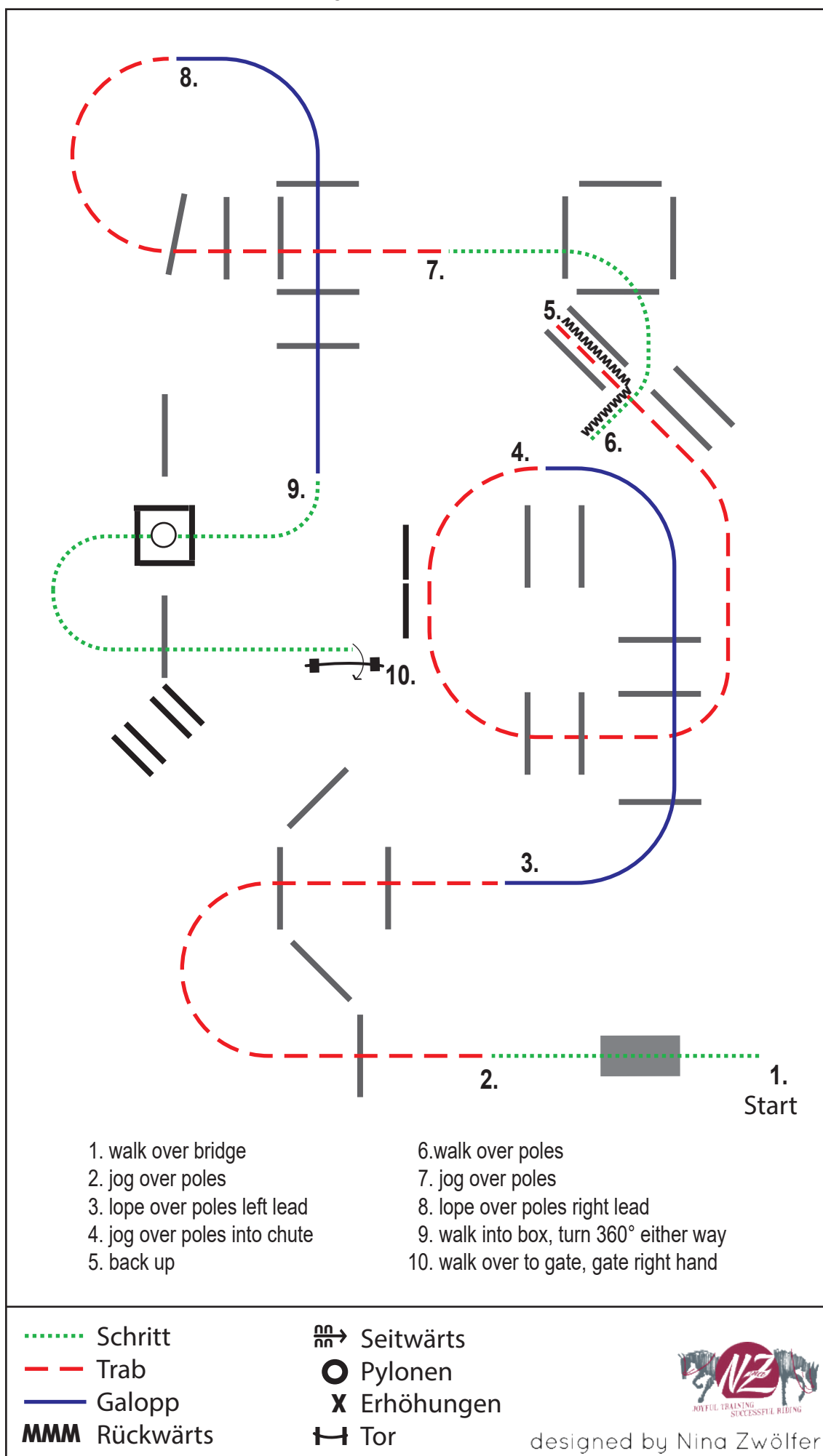

CWN-C ZNS / WTC Cup / BLMM / Senior Master / ARHA Challenge  
 Wr. Neustadt/NÖ \* 18.05. - 20.05.2024  
 33 Trail Youth

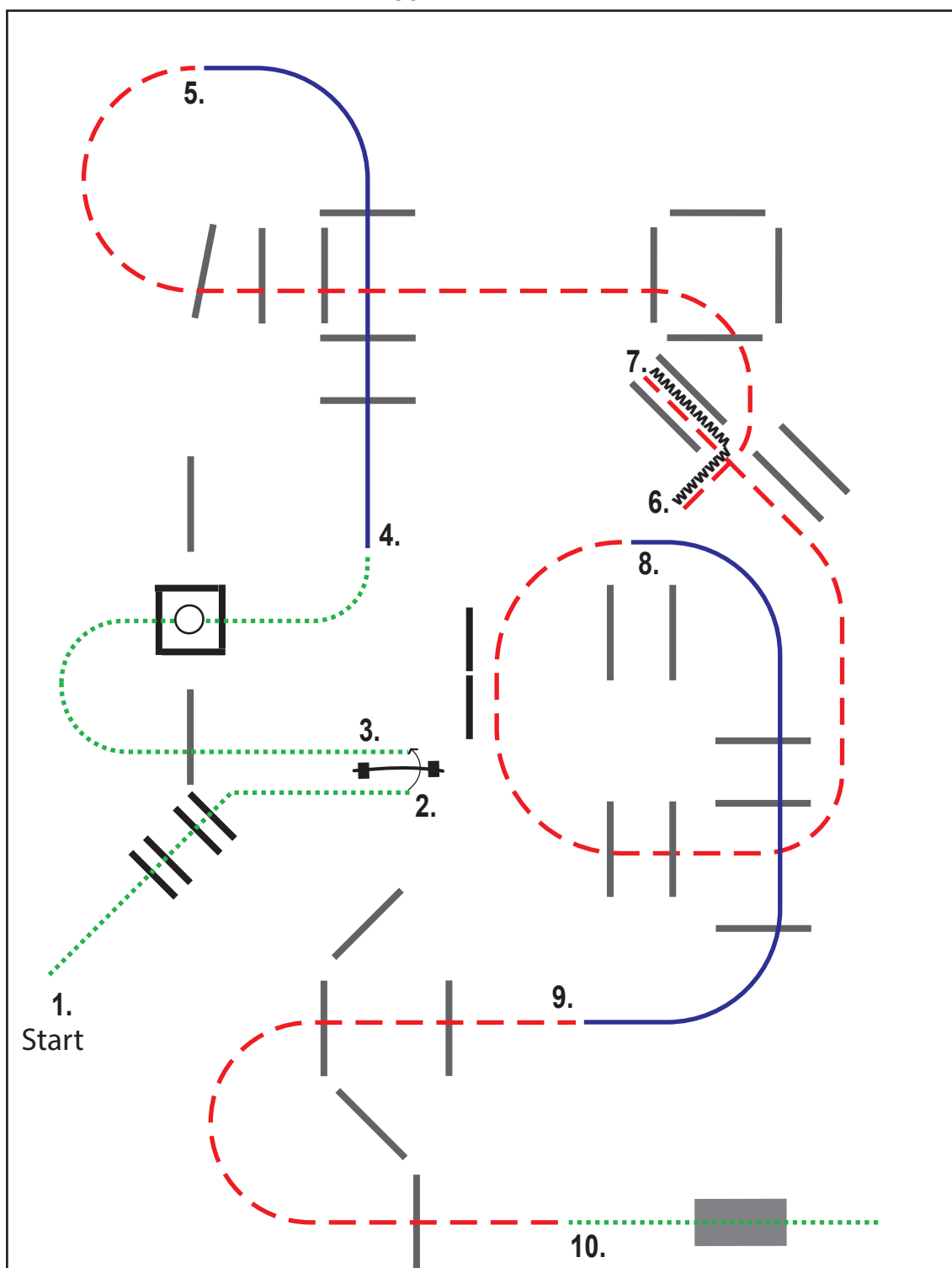

- 1. walk over poles to gate
- 2. gate left hand
- 3. walk over pole into box, turn 360° either way
- 4. lope over poles left lead
- 5. jog over poles

- 6. back up
- 7. jog out and over poles
- 8. lope over poles right lead
- 9. jog over poles
- 10. walk over bridge

- ..... Schritt
- - - - Trab
- Galopp
- MMM** Rückwärts
- $\frac{nn}{nn} \rightarrow$  Seitwärts
- Pylonen
- X** Erhöhungen
- T** Tor



designed by Nina Zwölfer



CWN-C ZNS / WTC Cup / BLMM / Senior Master / ARHA Challenge  
 Wr. Neustadt/NÖ \* 18.05. - 20.05.2024  
 34 Trail Open BLMM

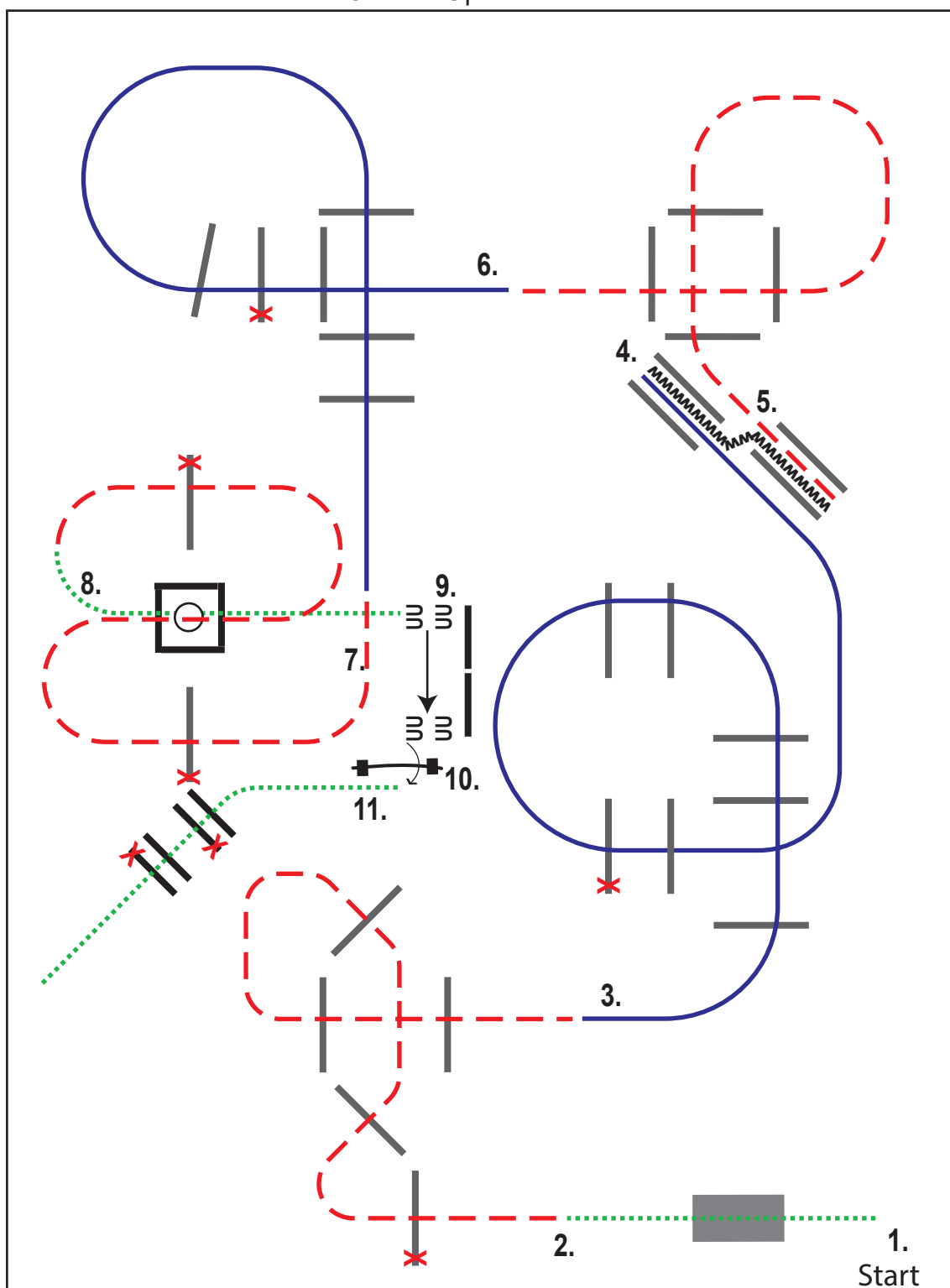

- |   |  |
|---|--|
| 1. walk over bridge                     | 7. jog over poles                                |
| 2. jog over poles                       | 8. walk into box, turn 720° either way, walk out |
| 3. lope over poles left lead into chute | 9. sidepass right to the gate                    |
| 4. back up                              | 10. gate right hand                              |
| 5. jog over poles                       | 11. walk over poles                              |
| 6. lope over poles right lead           |  |

- |                |              |
|----------------|--------------|
| ..... Schrittl | ↔ Seitwärts  |
| - - - - Trab   | ○ Pylonen    |
| ———— Galopp    | X Erhöhungen |
| MMM Rückwärts  | ⊥ Tor        |



designed by Nina Zwölfer

CWN-C ZNS / WTC Cup / BLMM / Senior Master / ARHA Challenge  
 Wr. Neustadt/NÖ \* 18.05. - 20.05.2024  
 35 Trail Amateur BLMM

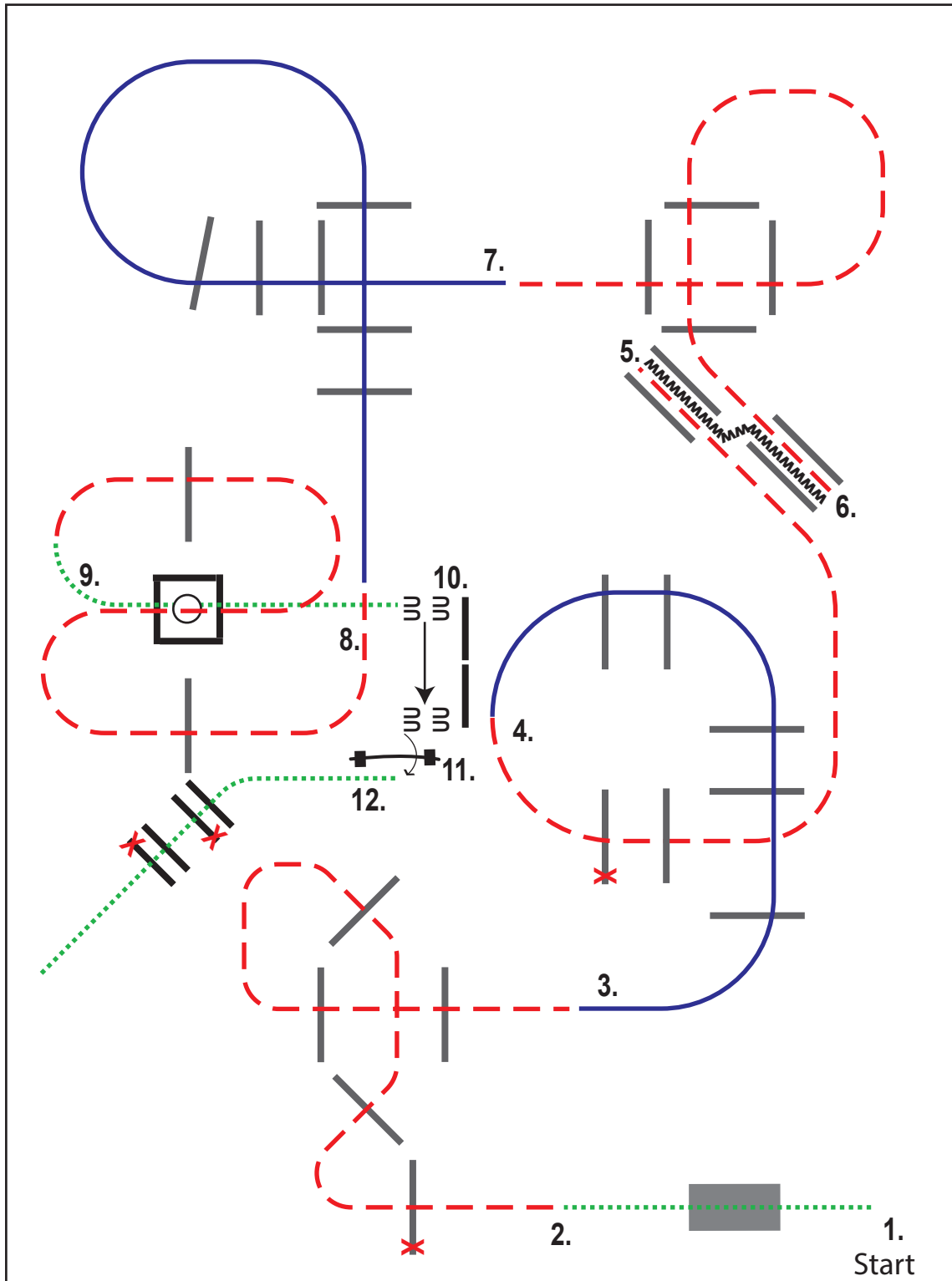

- |                              |  |
|------------------------------|--|
| 1. walk over bridge          | 7. lope over poles right lead                    |
| 2. jog over poles            | 8. jog over poles                                |
| 3. lope over poles left lead | 9. walk into box, turn 360° either way, walk out |
| 4. jog over into chute       | 10. sidepass right to the gate                   |
| 5. back up                   | 11. gate right hand                              |
| 6. jog over poles            | 12. walk over poles                              |

- |                |              |
|----------------|--------------|
| ..... Schritt  | ↔ Seitwärts  |
| - - - - - Trab | ○ Pylonen    |
| ———— Galopp    | X Erhöhungen |
| MMM Rückwärts  | ⊢ Tor        |



designed by Nina Zwölfer

CWN-C ZNS / WTC Cup / BLMM / Senior Master / ARHA Challenge  
 Wr. Neustadt/NÖ \* 18.05. - 20.05.2024  
 36 Trail Führzügelklasse

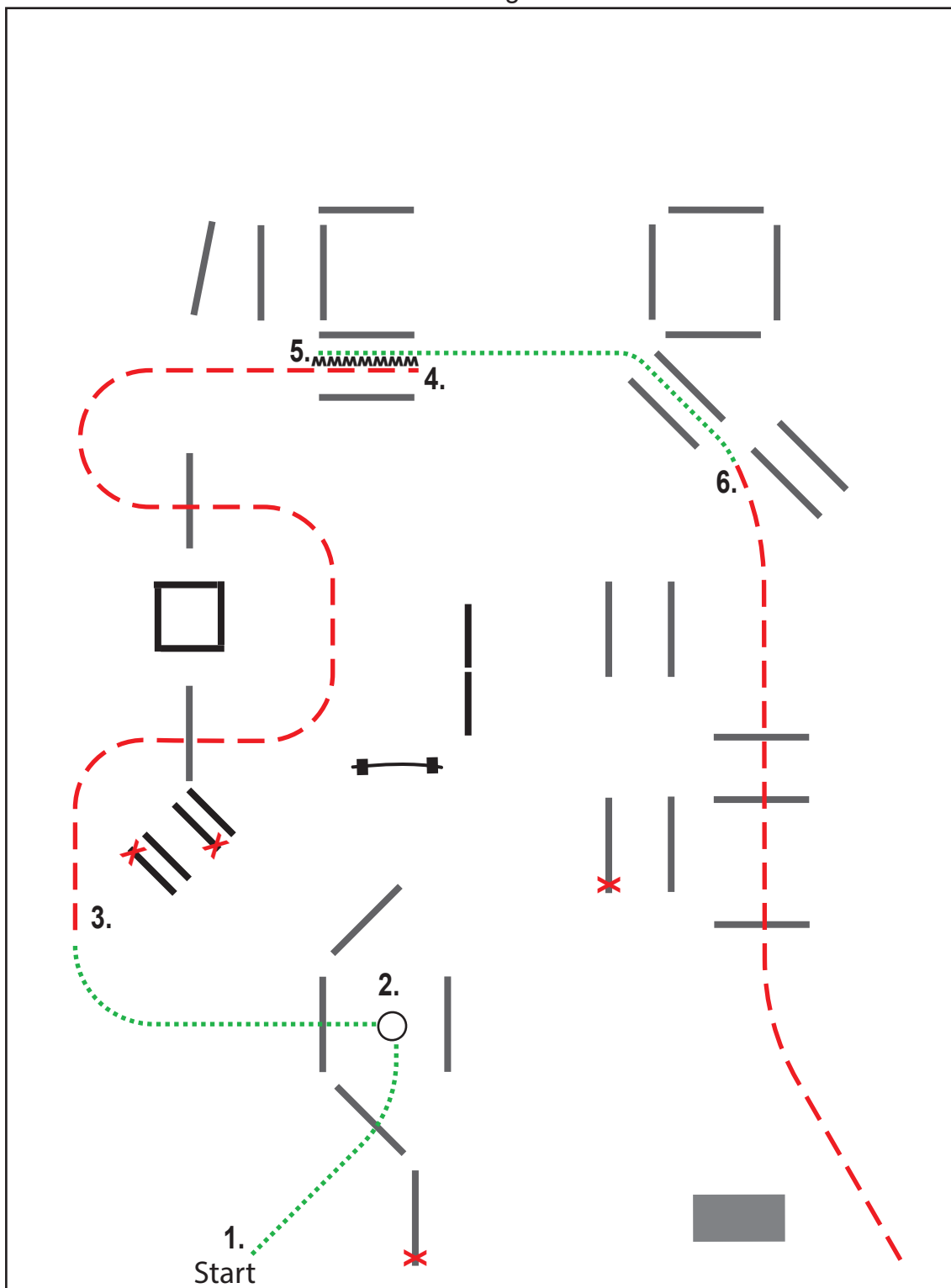

- 1. walk over pole into box
- 2. turn 270° right, walk out over pole
- 3. jog over poles into chute

- 4. back up
- 5. walk through poles
- 6. jog over poles

- ..... Schritt
- - - Trab
- — — Galopp
- MMM** Rückwärts
- Seitwärts
- Pylonen
- Erhöhungen
- Tor



designed by Nina Zwölfer

CWN-C ZNS / WTC Cup / BLMM / Senior Master / ARHA Challenge  
 Wr. Neustadt/NÖ \* 18.05. - 20.05.2024  
 68 Trail Youth EWU Qualifikation

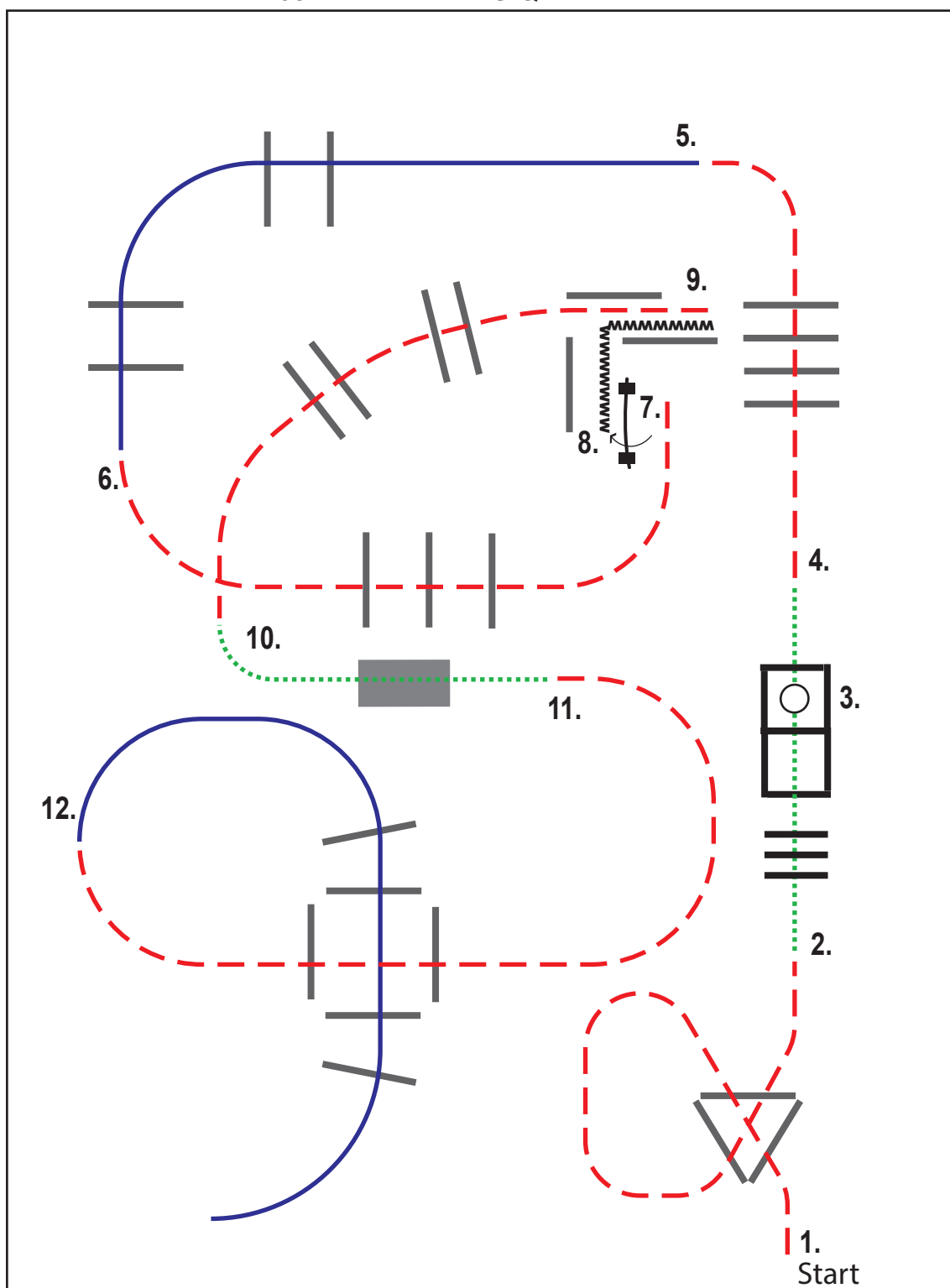

- |                                     |                                |
|-------------------------------------|--------------------------------|
| 1. jog over poles                   | 7. gate left hand              |
| 2. walk over poles and box into box | 8. back up                     |
| 3. turn 360° either way             | 9. jog over poles              |
| 4. jog over poles                   | 10. walk over bridge           |
| 5. lope over poles left lead        | 11. jog over poles             |
| 6. jog over poles to gate           | 12. lope over poles right lead |

- |           |            |
|-----------|------------|
| Schritt   | Seitwärts  |
| Trab      | Pylonen    |
| Galopp    | Erhöhungen |
| Rückwärts | Tor        |



designed by Nina Zwölfer

CWN-C ZNS / WTC Cup / BLMM / Senior Master / ARHA Challenge  
 Wr. Neustadt/NÖ \* 18.05. - 20.05.2024  
 69 Trail Novice Amateur

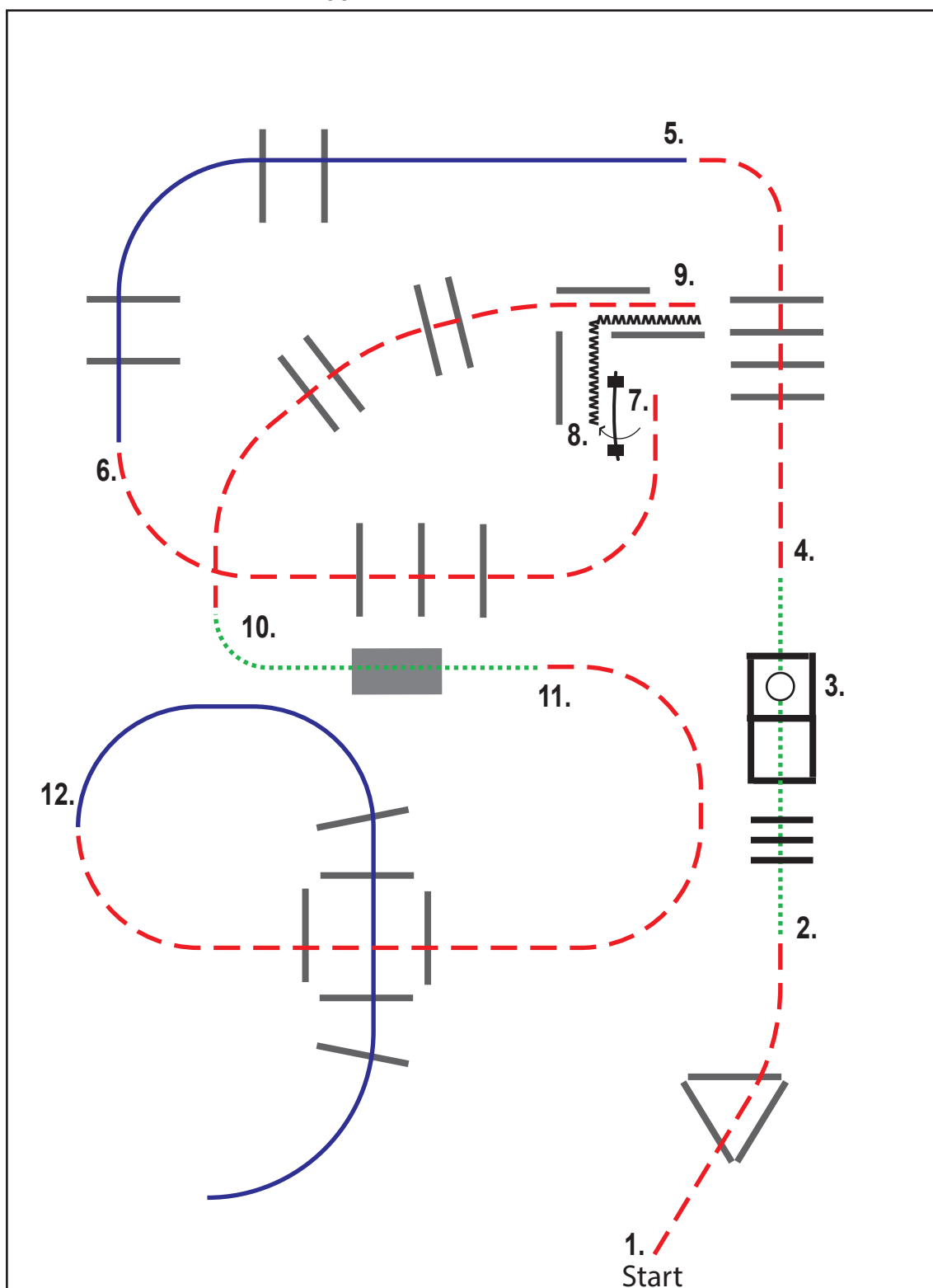

- |                                     |                                |
|-------------------------------------|--------------------------------|
| 1. jog over poles                   | 7. gate left hand              |
| 2. walk over poles and box into box | 8. back up                     |
| 3. turn 360° either way             | 9. jog over poles              |
| 4. jog over poles                   | 10. walk over bridge           |
| 5. lope over poles left lead        | 11. jog over poles             |
| 6. jog over poles to gate           | 12. lope over poles right lead |

- |                |              |
|----------------|--------------|
| ..... Schritt  | ↔ Seitwärts  |
| - - - - - Trab | ○ Pylonen    |
| ———— Galopp    | X Erhöhungen |
| MMM Rückwärts  | ⌋ Tor        |



designed by Nina Zwölfer

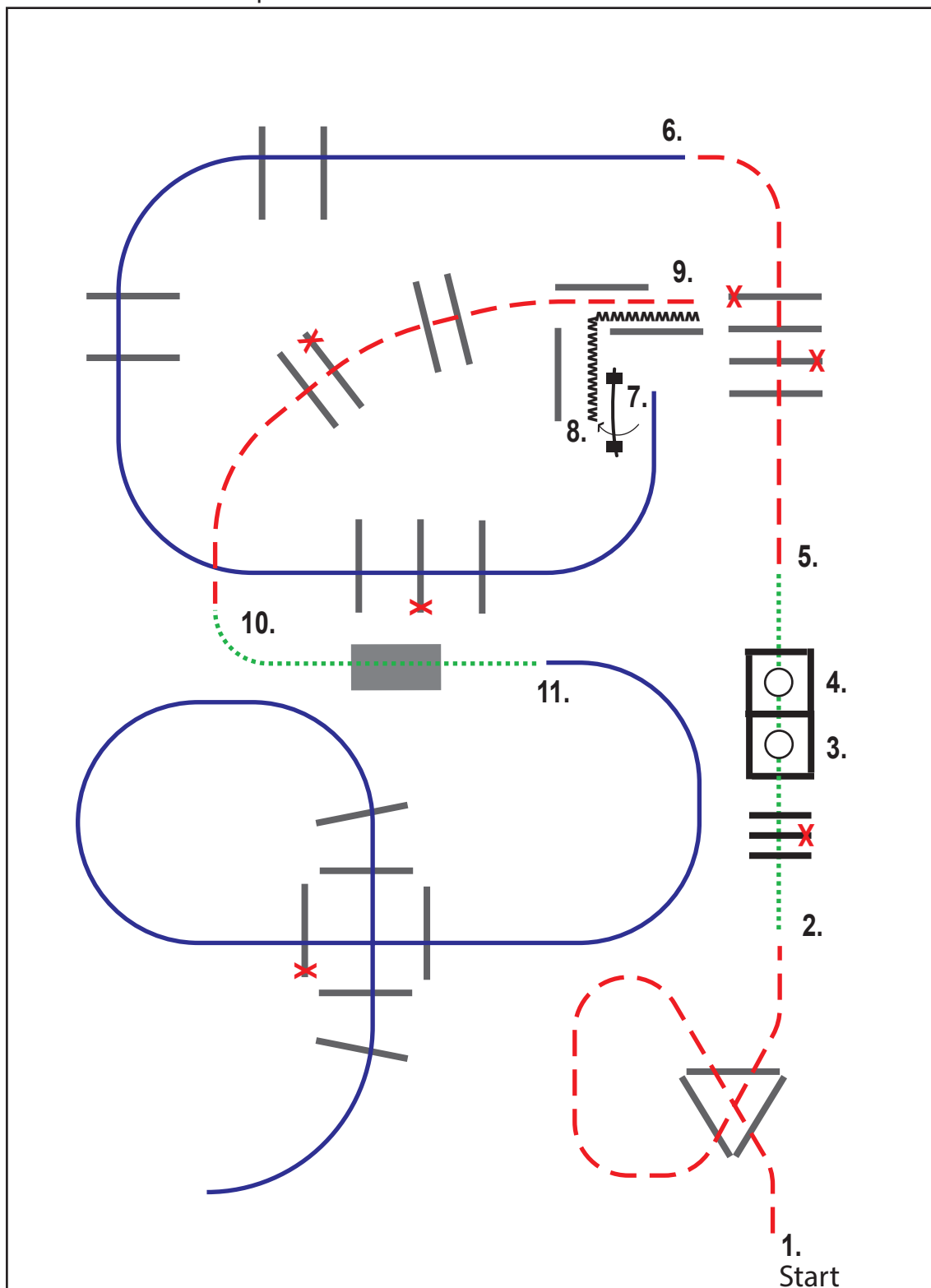

- |                                      |                                |
|--------------------------------------|--------------------------------|
| 1. jog over poles                    | 7. gate left hand              |
| 2. walk over poles into box          | 8. back up                     |
| 3. turn 360° left                    | 9. jog over poles              |
| 4. turn 360° right, walk out         | 10. walk over bridge           |
| 5. jog over poles                    | 11. lope over poles right lead |
| 6. lope over poles left lead to gate |                                |

- |                |              |
|----------------|--------------|
| ..... Schritt  | ↔ Seitwärts  |
| - - - - - Trab | ○ Pylonen    |
| — Galopp       | X Erhöhungen |
| MMM Rückwärts  | ⊢ Tor        |

