

ROOKIE HMS  
YOUTH HMS

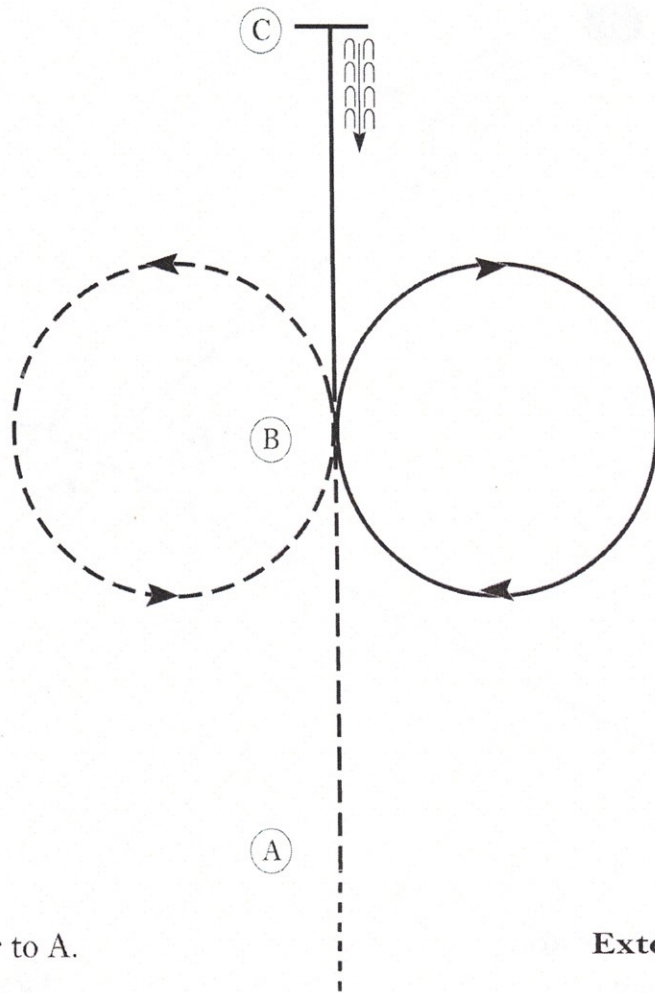

Be ready prior to A.

1. Walk to A.
2. Jog A to B.
3. At B jog a circle to the left.
4. At B lope a circle to the right on the right lead.
5. Continue the lope to C.
6. Stop at C and back approximately one horse length.

Walk	-----
Jog	-----
Extended Jog	-----
Lope	—————
Leg Yield	
Lead Change	↘
Back	←←←←←
Marker	(B)
Sidepass	←←←←←



Reitertreffen Wilfersdorf Warm Up 2024 13.04.2024

OPEN HWS

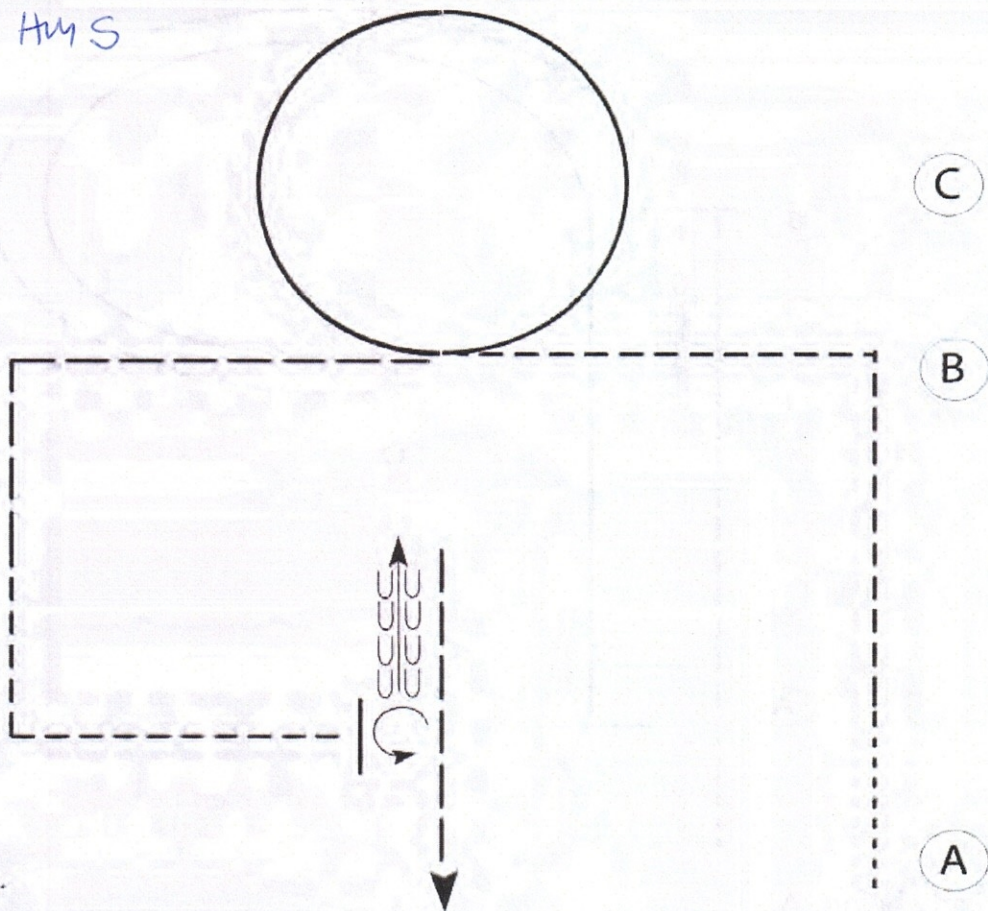

Be ready at A.

1. Walk approximately 2 horse lengths from A. Jog to B and a square corner to center.
2. Lope a circle to the right.
3. Extended jog thru first square corner. Slow to a jog midway and continue to jog through second corner.
4. Stop and perform a 270 degree turn to the left. Back one horse length.
5. Pattern is complete. Exit at the extended jog.

Walk	-----
Jog	- - - - -
Extended Jog	—————
Lope	
Lead Change	⌘
Back	← 55555
Marker	Ⓚ

Reitertreffen Wilfersdorf Warm Up 2024 13.04.2024

OPEN SMS

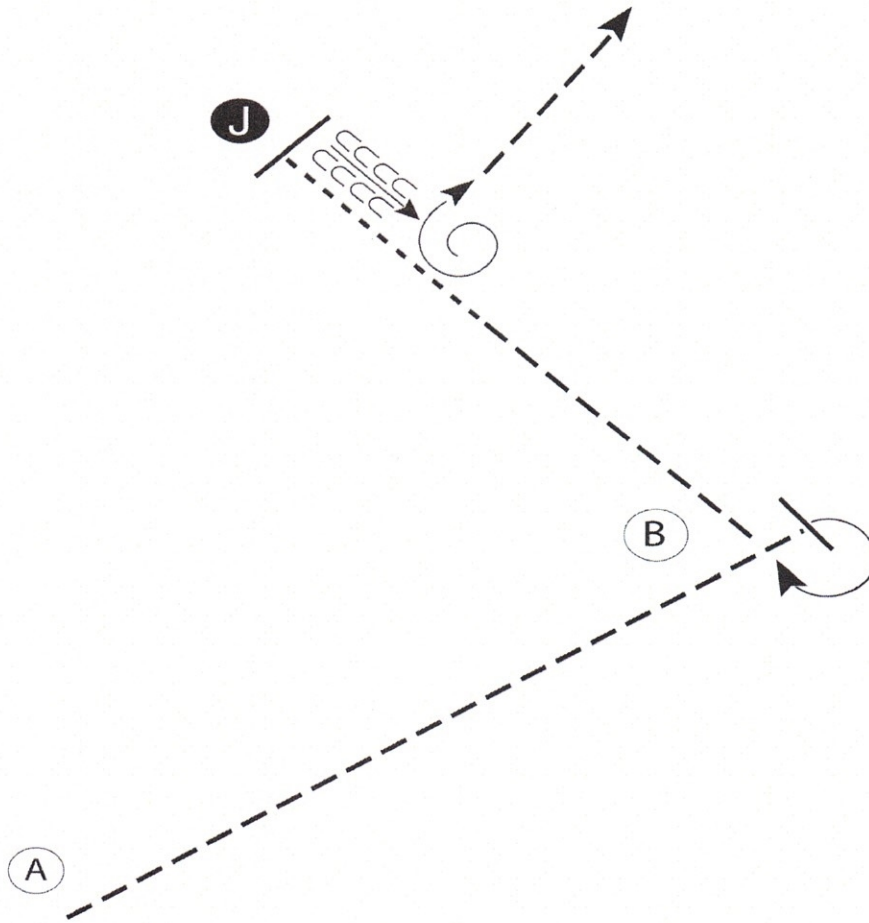

1. Begin at A. Trot past B and stop
2. Perform a 270 degree turn
3. Trot halfway to the Judge
4. Break to the walk and walk to the Judge
5. Stop and set up for inspection
6. When dismissed back one horse length
7. Perform a 450 degree turn and trot to the line-up

<b>Walk</b>	-----
<b>Trot</b>	- - - - -
<b>Back</b>	←
<b>Marker</b>	ⓑ
<b>Judge</b>	ⓐ